

L. K. FULLER.
ORGAN-CASES.

No. 190,843.

Patented May 15, 1877.

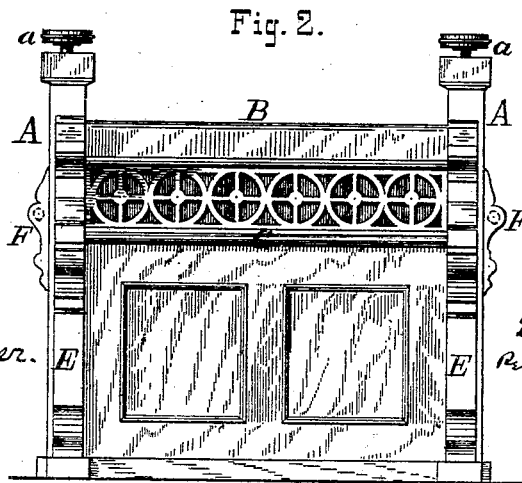
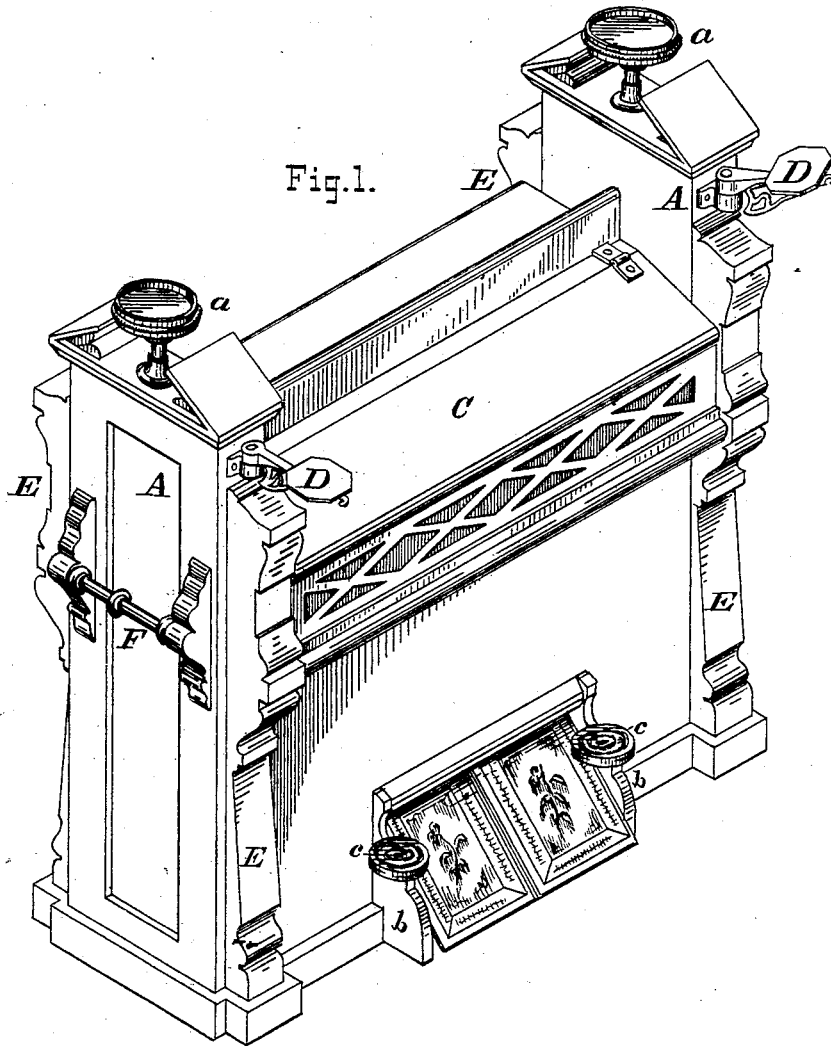

ATTEST:

Arthur C. Fraser.
Albert D. Miller

INVENTOR:

Levi K. Fuller
Per Burke & Fraser
Atty

UNITED STATES PATENT OFFICE.

LEVI K. FULLER, OF BRATTLEBOROUGH, VERMONT.

IMPROVEMENT IN ORGAN-CASES.

Specification forming part of Letters Patent No. 190,843, dated May 15, 1877; application filed March 9, 1877.

To all whom it may concern :

Be it known that I, LEVI K. FULLER, of Brattleborough, in the county of Windham and State of Vermont, have invented certain Improvements in the Construction of Organ-Cases, of which the following is a specification:

This invention relates to cases of portable reed-organs most particularly; and consists in various features of the construction, which will be fully hereinafter described.

It is known that organists of chapels, concert-halls, &c., would prefer to sit facing their audiences if it were not that the high backs or cases of the organs commonly used obscure the view. Moreover, the back of the ordinary organ-case presents an unsightly appearance, not always being intended for exhibition.

To construct an organ-case obviating these difficulties is one important feature of this invention.

In the drawings, Figure 1 is a perspective view of an organ-case embodying my improvements. Fig. 2 is a rear elevation of the same, drawn on a smaller scale.

A A are the elevated ends of the organ, mounted and fixed upon which are stands *a a*, which serve to support portable gas-burners, lamps, or vases of flowers. These stands may also be made highly ornamental, as well as useful.

About midway of the width of the organ, and between the ends, is fixed edgewise a supporting-strip, B, which serves to maintain the lid C, when open, at the proper angle to support the music-book. This strip may be plain, or cut in open fret-work. D D are lamp-stands or brackets, hinged to the front edges of the elevated ends A A.

Both elevated ends of the organ-case are constructed alike, and at each corner, both back and front, are fixed corner-posts E E. F F are handles, extending across the ends from stile to stile.

On the pedal-brackets *b b* are fixed foot-rests *c c*, upon which the foot may rest when not required to operate the pedals.

Fig. 2 shows the rear of the organ, which is arranged to present an equally-finished appearance with the front, so that it may be presented to the audience. Thus either side may be called the front, indifferently.

This last-mentioned face of the organ is

provided at the back of the action with an open-work strip, G, to permit the sound from the reeds to freely escape.

In the construction of this case the action-cover, between the elevated ends, must be kept down as near the level of the keys as convenient, so as to offer as little obstruction to the organist's view as possible, while the ends are elevated, as shown, to present an imposing appearance, and to form supports for the stands *a a*, as before set forth.

Having thus described my invention, I claim—

1. The combination of the elevated ends A A with the supporting-strip B and lid C, as and for the purposes substantially as set forth.

2. The combination of the elevated ends A A, constructed as shown, the stands *a a* fixed thereon, and the lower central portion of the case which contains the action, when arranged in the manner set forth.

3. The elevated ends A A, raised above the central part containing the action, provided at their front edges, at a point above the action, with hinged lamp-stands, as shown, as and for the purposes specified.

4. The combination of the foot-rests *c c* with the pedal-brackets *b b*, when arranged substantially as and for the purpose set forth.

5. The combination, in an organ-case, of the two elevated ends A A, provided with handles F F, stands *a a*, and like corner-posts E E on opposite edges, with the lower central portion of the case containing the action, all arranged substantially as herein set forth.

6. An organ-case with elevated ends A A, provided at their rear edges with posts E E, in combination with a lower central portion containing the action, and provided with an open-work strip, G, the same being for the purpose of permitting the sound to escape, and, at the same time, enhance the appearance of the rear of the organ, all as and for the purpose set forth.

In witness whereof I have hereunto signed my name in the presence of two subscribing witnesses.

LEVI K. FULLER.

Witnesses:

J. E. HALL,
W. H. CHILDS.