

B. H. MUEHLE.

MEANS FOR PROPELLING CANAL BOATS

No. 190,975.

Patented May 22, 1877.

Fig. I

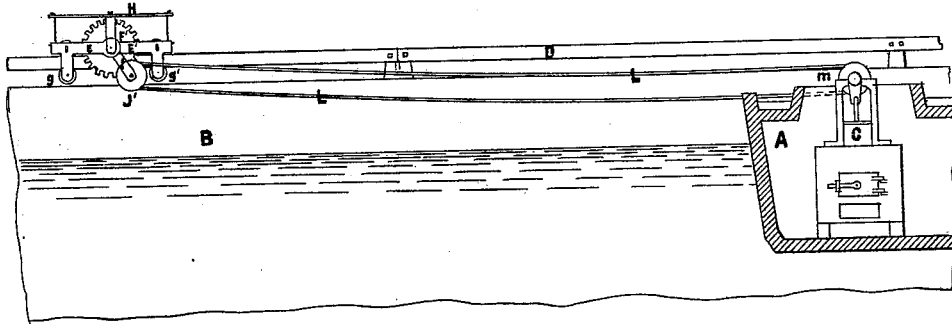

Fig. II

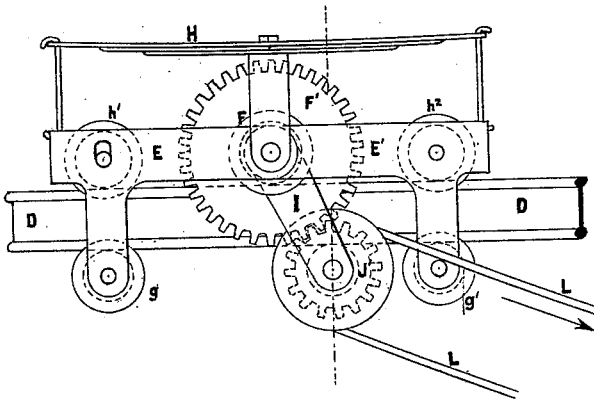

Fig. III

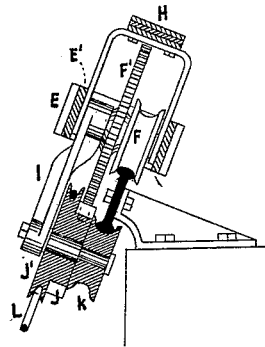

Fig. IV

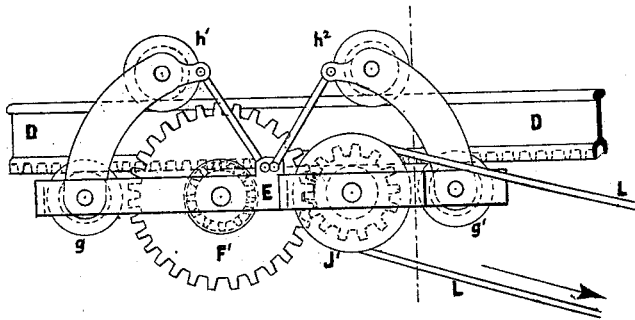
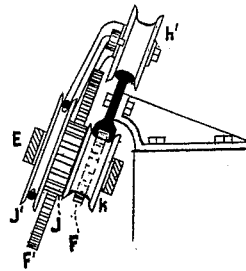

Fig. V



WITNESSES:

J. F. Ernst Jr
W. K. Crook

INVENTOR:

Bernard H. Muehle

UNITED STATES PATENT OFFICE

BERNARD H. MUEHLE, OF BUFFALO, NEW YORK.

IMPROVEMENT IN MEANS FOR PROPELLING CANAL-BOATS.

Specification forming part of Letters Patent No. **190,975**, dated May 22, 1877; application filed September 26, 1876.

To all whom it may concern:

Be it known that I, BERNARD H. MUEHLE, of the city of Buffalo, in the county of Erie and State of New York, have invented a new and useful Improvement in Propellers for Canal-Boats, which improvement is fully set forth in the following specification, reference being had to the accompanying drawings, in which—

Figure I is a side elevation of my improvement, showing the canal-boat. Fig. II is a side elevation of the propelling-carriage on a section of rail. Fig. III is a transverse vertical section of the same. Figs. IV and V show a modification in the construction of the carriage and rail, as hereinafter described.

The object of my invention is to make steam-power available for propelling canal-boats or vessels in the most economical and efficient manner possible. To accomplish this I deem it necessary to imitate as near as possible the present greatly-objectable propelling-power—the horse or other draft animal. In accordance with this idea I construct a tow-path in the shape of a rail or rails, place thereon a truck or carriage in lieu of the horses, and use an endless rope or chain instead of, and operating the same as, a single tow-line, so that said endless rope or chain acts in two capacities simultaneously: first, as a conveyer of power from a steam-engine or other motor on the canal-boat to be propelled; and, second, as a tow-line, without any other rigid, flexible, or adjustable connection between the independent carriage on the rail or bank and the canal-boat or vessel being required, thereby permitting the boat to be steered and managed with the same ease and in a manner similar to a canal-boat pulled by horses. And right here I would state that my invention is not intended to accomplish more than horses can do; but I intend and claim that it will do fully as much, and hence furnishes a complete and most economical substitute for the horses.

In the accompanying drawings, A represents a portion of a canal-boat, (shown in longitudinal section,) and B one of the banks of the canal. C represents a steam-engine and boiler, which may be located within the bow

or upon the deck of the boat, and furnishes the motive-power, as hereinafter described. D represents a two-headed or double T-rail, which is secured to the edge, top, or side of the bank of the canal by means of posts, piles, brackets, or other suitable devices, the point of connection being between the two heads or bearing-surfaces upon one side of the shank of the rail, as shown in Figs. III and V. The flat side or shank of the rail may be either vertical, horizontal, or oblique; but I have shown the same in the drawings in an oblique position.

Although I consider a double T-rail sufficiently strong for the purpose, and, of course, less expensive, I do not debar myself from using two rails instead of one, nor from adopting a sheathed or iron-shod plank for the same purpose, as I consider them equivalents of the rail shown in the drawings.

Upon this rail D I place a truck or carriage, which is constructed as follows: A frame is made of two parts, E E', both being hinged to the main shaft, which carries the flanged traction-wheel F and spur-wheel F'. The traction-wheel and spur-wheel are keyed together. The extreme ends of the sections of frame are provided with flanged guide-wheels *g g'*, which bear upon the surface of the rail opposite to that on which the traction-wheel travels. A spring, H, or its equivalent, serves to force the traction-wheel F and guide-wheels *g g'* in opposite directions, so as to cause the former to take hold of and press upon the rail, and by its revolutions around its axis move the carriage upon the rail. Adjustable guide-rollers *h¹ h²* are placed upon the frame opposite the wheels *g g'*, or at any other suitable points, for the purpose of holding the carriage firmly to the rail.

These guide-rollers may be hung in sliding boxes (see Fig. II) or upon the ends of hinged arms, (see Fig. IV,) and so as to enable the boatman to move them toward or from the rail, and secure them at any desired distance from the guide-wheels *g g'*. Thus, by moving the guide-rollers *h¹ h²* toward the wheels *g g'* in a manner that the flanges of both sets of wheels or rollers overlap the bearing-surfaces of the rail, the carriage is secured independ-

ently upon the rail, and does not require any other rigid, flexible, or adjustable connection with the boat to be propelled.

By loosening the guide-rollers $h^1 h^2$, the little carriage may be readily removed from the rail and laid on the deck of the vessel, or otherwise stored, until it may be required again for service.

I represents an armor lever, which is hinged to the main shaft, and carries upon its extreme end a counter-shaft or fixed spindle in a position parallel to the main shaft. A pinion, J, and a pulley or chain-wheel, J', are placed upon said spindle, the former gearing with the spur-wheel F' upon the main shaft in such manner that, as the pulley is revolved, the rotary motion is conveyed through the gearing to the traction-wheel F, and thereby the carriage moved along in either direction desired. A friction-roller, k , upon the extreme end of the spindle, bears against the face-rail, for the purpose of preventing the pulley and pinion from coming in contact with the frame of the carriage, and also for increasing the friction of the traction-wheel upon the rail in proportion to the load to be drawn by the carriage.

This arm I is hinged to, and revolves upon, the axle of the traction-wheel, so that it may be swung backward or forward of the same, while at the same time the spur-wheel remains in gear with the pinion, which is the prime mover of the carriage. Power is not applied to the traction-wheel direct, but through the medium of multiplying-gearing in such manner that sufficient power is obtained to overcome the friction of the wheels of the truck upon the rail. This is a most essential feature of my invention, as without the reduction of the speed of the prime mover, and the consequent gain of power applied to the traction-wheel, my invention, as briefly explained above, would be inoperative and of no practical value. This arrangement of parts in a propelling-carriage, operated by an endless rope or chain, by means of which power is gained through a corresponding reduction of speed, I believe has never been applied to the various devices for propelling canal-boats by steam, while it forms an important parts of my invention.

When two rails are used, instead of one double-headed one, the construction of the carriage will be modified accordingly, though the main parts will be the same, operating in the same manner; and the carriage, in all its modifications, will always contain one or more traction-wheels with spur-wheels attached, one or more pinions gearing with the latter, and a pulley or chain wheel connected with the pinion.

In Figs. IV and V, I have shown a modification of the carriage, which also includes and necessitates a change in the construction of the rail, the latter being provided with cogs or transverse corrugations. In this case the traction-wheel has corresponding cogs or transverse corrugations, which gear with those upon

the rail; consequently the frame E may be made in one piece and rigid. The essential parts of the carriage, however, are the same as above described—a spur-wheel, F', attached to the traction-wheel upon the main shaft, a pinion, J, and pulley J' on a countershaft, flanged wheels $g g'$, and adjustable guide-rollers $h^1 h^2$.

In order to make this carriage reversible the arm I may also be added, as a connection between the axle of the traction and spur wheel and that of the pinion and pulley, and operate as above described.

L represents an endless rope or chain, by means of which the carriage is propelled. It passes over the pulley or chain wheel J', and also over a driving-pulley or chain-wheel, m , upon the canal-boat to be propelled. Power being applied to the pulley m by means of the steam-engine C or other prime mover the rotary motion of this pulley is communicated to the pulley J' on the carriage, through the endless rope or chain, and hence the carriage is moved along upon the rail and draws the canal-boat after it, the endless rope or chain thus acting as a conveyer of power and motion, and as a tow-line simultaneously.

The operation of my improved apparatus is as follows: The carriage is first placed upon the rail and secured by means of the adjustable guide-rollers $h^1 h^2$, as hereinbefore described, the rope or chain being properly passed over the pulleys J' and m ; then the engine is started, the pulleys revolved, and the rope or chain drawn from the carriage to the boat, so as to start and move the carriage in a direction opposite to that in which the rope is pulled—*i. e.*, from the boat—the latter remaining stationary for the present. As the carriage moves away the loose portion of the endless rope or chain, which may be coiled up on the deck of the boat, will be payed out until the rope or chain throughout its entire length becomes taut; then the same assumes the character of a tow-line, in addition to that of conveyer of power and motion, and it draws the boat after the moving carriage. When it is desired to stop the motion of the canal-boat the pulley m , by means of clutch arrangement or otherwise, is disconnected from the revolving driving-shaft of the engine, and thereby the carriage is stopped the same as horses are stopped now. By reason of its momentum the boat will approach the place where the carriage is at rest, and may be stopped or snubbed in the usual manner.

The most important advantage which my improvement possesses over other devices for propelling canal-boats which take hold of a fixed rail or the bank of the canal consists in that my connection between the carriage and the boat is flexible, and may be made as long as a common tow-line, and thus permit the boat to be steered as readily as it can now be done, clearing passing boats and such as may be lying against the bank or dock, or obstruct-

tions of any kind, as easily as the same can now be done where canal-boats are propelled by animals with a common tow-line.

I claim as my invention—

1. The tow-line L, consisting of an endless rope or chain, by means of which power is communicated from a steam-engine or other motor on the canal-boat to be propelled to a truck or carriage on a rail or rails, through the medium of a train of multiplying-gearing upon said carriage, substantially as and for the purpose herein described.

2. A truck or carriage, moving upon a rail or rails, and having a traction-wheel, F, and spur-wheel F' on a main shaft, and the pinion J and pulley J' on a counter-shaft, power being applied to said pulley J' by means of the

endless rope or chain L, which forms the only connection between the carriage and a steam-engine or other motor on the canal-boat to be propelled.

3. In a propelling carriage, which is set in motion by means of an endless rope or chain, forming the only connection between said carriage and a motor on board the canal-boat, the arm I, in combination with the traction-wheel F, spur-wheel F', pinion J, and pulley J', as a means of reversing the motion of the carriage, substantially as herein described.

BERNARD H. MUEHLE.

Witnesses:

J. F. ERNST, Jr.,
W. K. PROVOST.