

C. DEGUINE.  
FURNACE-GRATE.

No. 191,002.

Patented May 22, 1877.

Fig. 1.

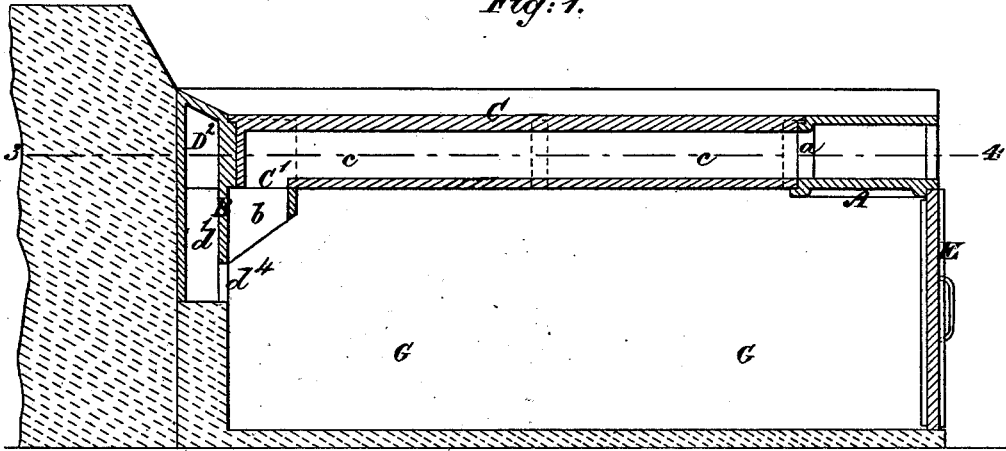
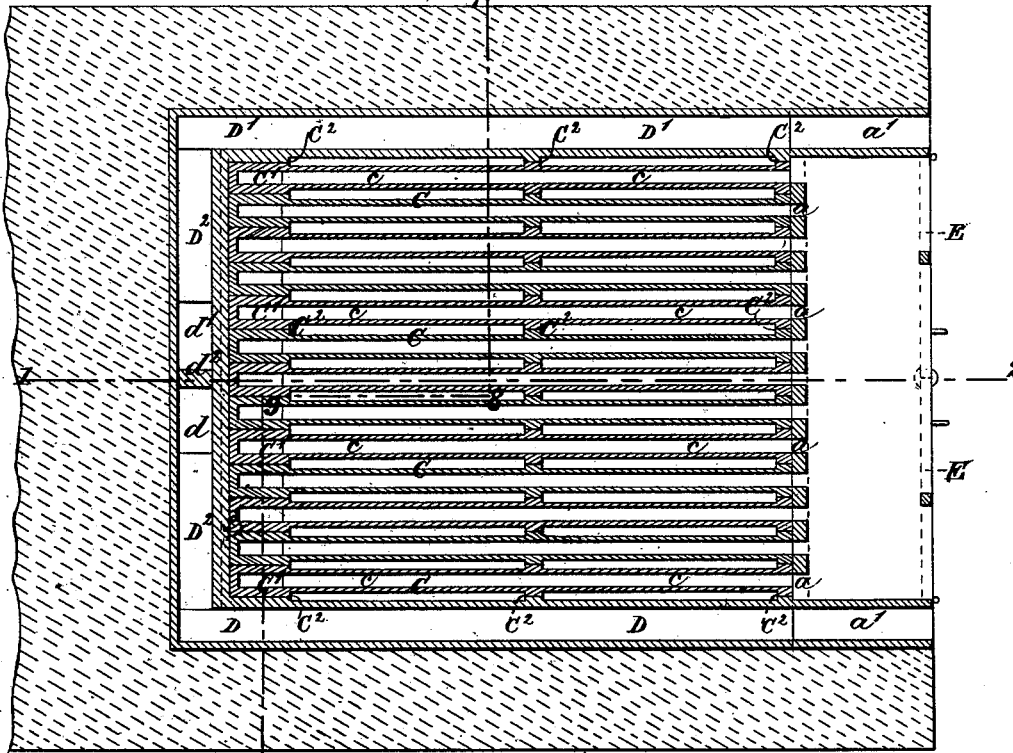

Fig. 3.



WITNESSES:

*Wm. A. Shinkle*  
*Henry T. Earnest*

INVENTOR

By his Attorneys  
*Casimir Deguine.*  
*Baldwin, Hopkins & Peyton.*

C. DEGUINE.  
FURNACE-GRATE.

No. 191,002.

Patented May 22, 1877.

Fig. 2.

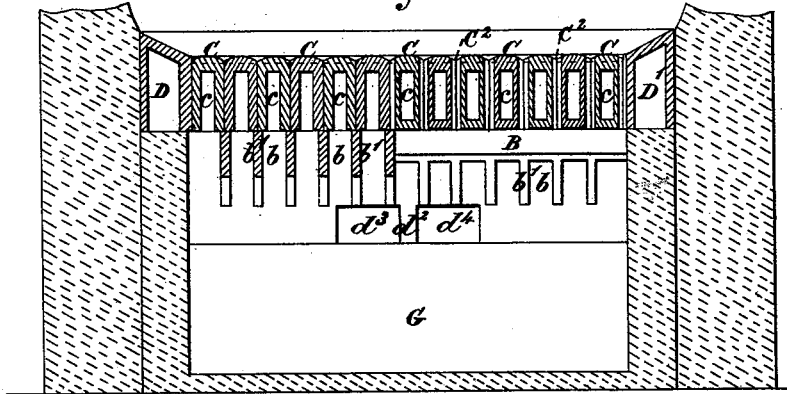

Fig. 4.

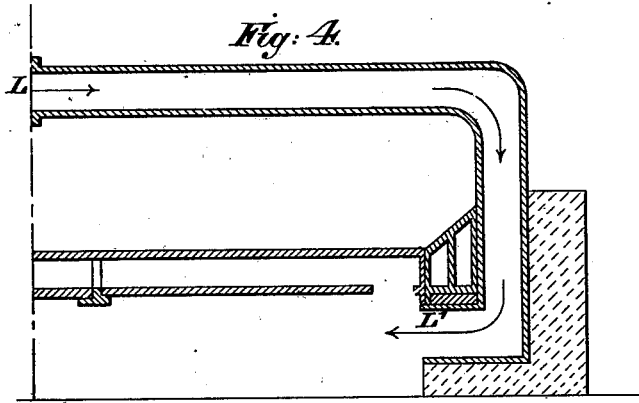

Fig. 5.

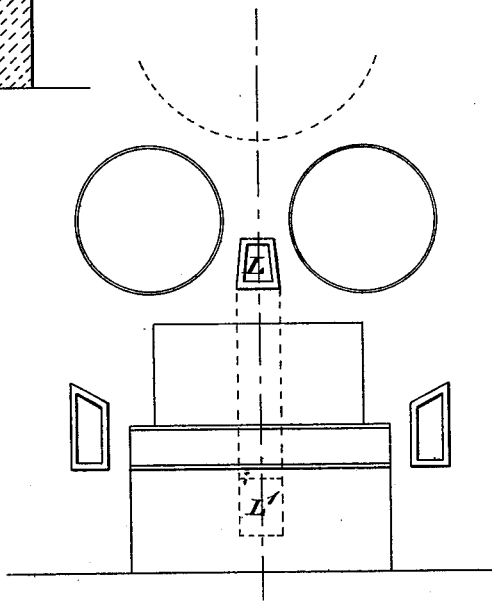
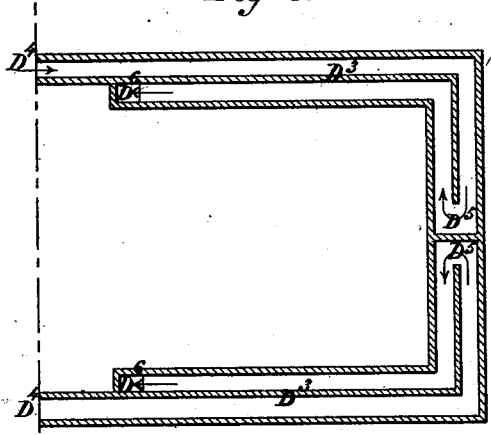

Fig. 6.



WITNESSES:

*Wm A Skinkle*

*Henry T. Earnest*

By his Attorneys,

*Baldwin, Hopkins & Lyton.*

INVENTOR:

*Casimir Deguine*

# UNITED STATES PATENT OFFICE.

CASIMIR DEGUINE, OF BOULOGNE-SUR-MER, FRANCE.

## IMPROVEMENT IN FURNACE-GRATES.

Specification forming part of Letters Patent No. 191,002, dated May 22, 1877; application filed April 11, 1877.

### *To all whom it may concern:*

Be it known that I, CASIMIR DEGUINE, of 7 Rue Montebello Capecure, Boulogne-sur-Mer, France, have invented new and useful Improvements in Furnace-Grates, such improvements being applicable to all kinds of ovens, furnaces, stoves, and fire-places, which improvements are fully set forth in the following specification, reference being had to the accompanying drawings.

The object of this invention is the construction of furnace-grates adapted to steam-boilers and other furnaces, and my improvements are essentially the same as shown in my English Letters Patent No. 2,983 of 1874.

The principle upon which my invention is based is to cause air already highly heated to pass through the fuel in the grate, and I accomplish this in the following manner: I entirely, or almost entirely, exclude the cold air from the ash-pit, and I employ hollow fire-bars, which permit the air to enter in front facing the furnace, and conduct it to the bottom of the hearth and to the closed ash-pit, and afterward the air passes through the grate and the coal or other fuel in combustion therein, the air having become much heated in its passage through the hollow fire-bars. I increase the capacity of the air openings and spaces by placing all around the grate large flues, acting in conjunction with the fire-bars thereof.

And in order that my invention may be better understood and more readily carried into operation, I will now proceed to describe the sheet of drawings hereunto annexed.

Figure 1 is a longitudinal section along the line 1 2 of the plan. Fig. 2 is a transverse section following the broken line 7 8 9 10 of the plan. Fig. 3 is a plan of the fire-bars of the grate and the exterior flues following the line 3 4 on Fig. 1.

In Figs. 1, 2, and 3 similar letters and figures of reference refer to similar parts.

A is a fire-bar lug or bearer, resting at its two extremities upon the vertical walls of the furnace. It is formed with rectangular openings *a a a*, corresponding in number and size to the fire-bars of the grate; those at the extremities *a' a'* are made larger, to correspond with the flues. B is a fire-bar lug or support,

resting in a similar manner upon the walls of the furnace at its two extremities, and formed on its horizontal part with openings *b*, intended to receive the open parts at the extremities of the fire-bars. Each aperture is separated from the next by a rib or bracket, *b'*. C C are fire-bars, of a suitable size and number, according to the form of the grate for which they are used. In the drawings they are shown of a rectangular form, slightly rounded at the top, and having throughout their length hollow grooves *c c*, terminating in an opening at C<sup>1</sup>. These bars are placed side by side at a suitable distance apart, and fixed in their required positions by small counterparts or buttresses C<sup>2</sup> C<sup>2</sup>.

D D<sup>1</sup> are flues, resting on the walls at the two sides of the fire-place. They are made hollow, and of the shape shown at Fig. 2, and are open in the front part. They are united at the back to a similar flue, D<sup>2</sup>, having in its center a partition, *d*<sup>2</sup>, and two apertures, *d d*<sup>1</sup>, so that the air which enters at the flue D escapes through the opening *d*, and that which enters the flue D<sup>1</sup> escapes through the aperture *d*<sup>1</sup> and enters the ash pan through the apertures *d*<sup>3</sup> *d*<sup>4</sup>. Fig. 6 represents these flues with diaphragms or central partitions D<sup>3</sup>, of such a form that the exterior air entering by the openings D<sup>4</sup> D<sup>4</sup> passes round D<sup>5</sup> and escapes to the ash-pan by the openings D<sup>6</sup>. The ash-pit is shut up by doors E, of sheet-iron.

The action of this furnace is extremely simple. The ash-pit being previously closed, the exterior air enters by the opening *a*, introduces itself into the hollow bars forming the grate, and at the extremity C<sup>1</sup> descends into the ash-pit G, where it again ascends, passing through the grating and the fuel thereon.

It will be readily understood that the fresh air, passing through each of these red-hot bars, reaches the closed ash-pan at a very high temperature, and again escaping passes between the fire-bars of the grate and assists the combustion of the fuel thereon at this high temperature. The flues D and D<sup>1</sup> are intended to augment the quantity of hot air admitted to the grate.

Figs. 4 and 5 show the application of passages L above the fire-bars to increase the supply of hot air to the ash-pit. The air en-

ters and passes along the horizontal passage L to the extremity of the fire-grate, then descends and passes by the opening L' into the ash-pit.

Having thus particularly described and ascertained the nature of my said invention, and how the same may be carried into practical operation, I would have it understood that what I claim is—

1. The combination of fire-bar lugs or bearers A B, having openings *a b*, and the hollow fire-bars C, receiving air at their front ends by the openings *a*, and terminating in downward openings C' at their rear ends, communicating by the openings *b* with the ash-pit, substantially as set forth.

2. The combination, substantially as hereinbefore set forth, of the ash-pit, the hollow fire-bars delivering the air downward into said pit at their rear ends, the side flues and the back flue by way of which the heated air passes to the ash-pit beneath the fire-bars.

3. The combination of the ash-pit, the side flues, and the rear flue, having a central partition and apertures at the sides of partition, to direct the heated air to the ash-pit in divided currents, substantially as set forth.

CASR. DEGUINE.

Witnesses:

L. DAGUER,  
F. PESTAIE.