

R. B. EASON.
 CAR AXLE-BOX.

No. 191,037.

Patented May 22, 1877.

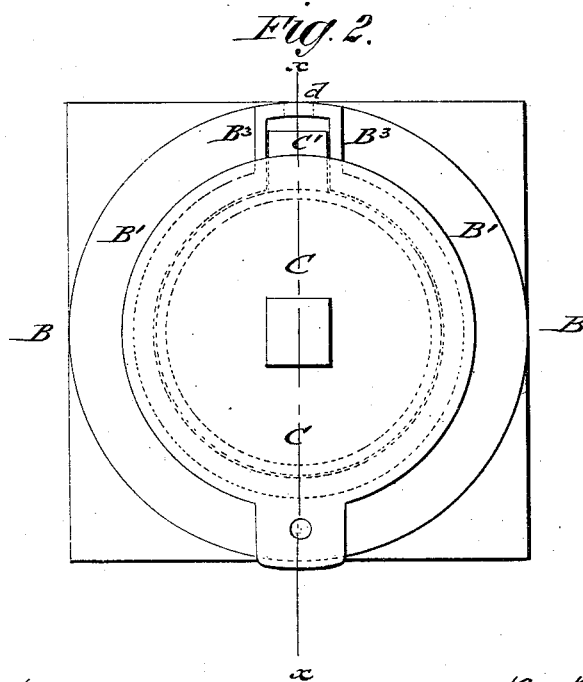
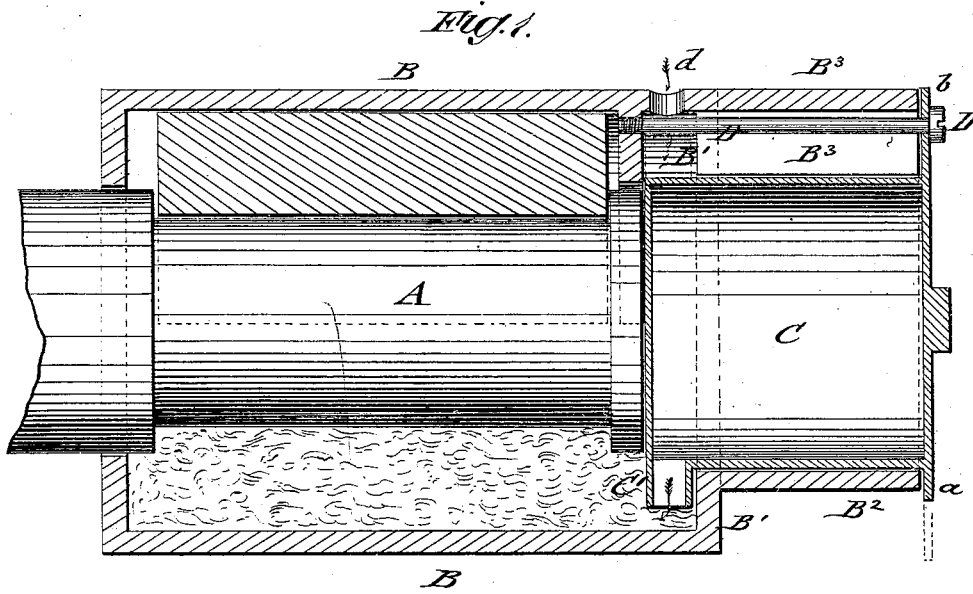

WITNESSES:
Francis McArdle,
J. H. Scarborough.

INVENTOR:
R. B. Eason.
 BY *Munnell*
 ATTORNEYS.

UNITED STATES PATENT OFFICE

RICHARD B. EASON, OF NEW YORK, N. Y., ASSIGNOR TO HIMSELF AND
SILAS A. ALLEN, OF SAME PLACE.

IMPROVEMENT IN CAR-AXLE BOXES.

Specification forming part of Letters Patent No. **191,037**, dated May 22, 1877; application filed
April 2, 1877.

To all whom it may concern:

Be it known that I, RICHARD B. EASON, of the city, county, and State of New York, have invented a new and Improved Car-Axle Box, of which the following is a specification:

In the accompanying drawing, Figure 1 represents a vertical longitudinal section on line *x*, Fig. 2, of my improved car-axle box; and Fig. 2, an end view of the same, showing the oil-receptacle in position for being filled.

Similar letters of reference indicate corresponding parts.

The object of my invention is to furnish, for car-axle, shafting, and other purposes, an improved self-lubricating journal-box, that prevents the waste of oil from the box, facilitates the supplying of the same without opening the box, and produces a considerable saving in oil, as only the quantity required for lubrication is furnished.

The invention consists of a car-axle box having a flanged oil chamber or receptacle with an exit-spout coming in contact with the packing of the journal. The oil-receptacle turns in bearings of the box, to bring the exit-tube below a top opening for filling the same with oil. On turning it down again it is secured in position by a fastening-bolt at the top passing through an extension flange of the receptacle.

In the drawing, A represents the car-axle, on which is placed, in the customary manner, the box or pedestal B, which is provided with a cylindrical step or base, B¹, and with a cylindrical extension or front, B², of smaller diameter than the base part B. The extension B² is closed by a flanged cylindrical oil vessel or receptacle, C, that is closed at both ends, and provided with an exit or discharge opening or spout, C', that is introduced into the interior of the box by a top channel or casing, B³, of the extension B², the spout C' being readily swung with the oil-receptacle along the larger base part B into downward position in the box, as shown in Fig. 1, by a square head of the oil-receptacle, or in other manner.

The flange *a* of the oil-vessel C has a top extension, *b*, that closes the guide-casing B³,

the oil-receptacle being secured when the spout is in downward position, and the extension-flange at the top part, by a screw-bolt, D, that passes longitudinally through flange *b* and the top channel B³; and screws into a solid cross-rib of the box B.

When it is desired to fill the oil-receptacle C with oil, the bolt is removed, the receptacle turned until the spout arrives below the top hole *d* of the box, when the oil may be readily poured in from the cau until the receptacle is filled. It is then turned down again until the spout is at the lower position in contact with the packing of the journal, and the extension-flange at the top ready to be locked by the fastening-bolt.

The oil is drawn out from the oil-receptacle by the capillary attraction of the packing as it is spent by the revolving of the axle, no oil running out from the receptacle when the axle is not in motion, as the partial vacuum at the upper part of the receptacle suspends the oil, and prevents the running out of the same at the rear part, which forms the most frequently-occurring source of waste in axle-boxes. As soon as the axle is in motion the oil is supplied to the journal and drawn out again from the oil-receptacle, sufficient air percolating through the packing to admit the oil to follow the capillary attraction of the packing.

The packing may be readily replaced, from time to time, by removing the bolt, and turning and detaching the entire receptacle, the box being then open, so as to get at the interior parts.

The same principle of the revolving oil-receptacle may also be applied to the journal-boxes of shafting for transmission, and in machinery generally.

Having thus described my invention, what I claim as new, and desire to secure by Letters Patent, is—

1. The combination, with a car-axle box, having cylindrical guide-extensions, of a revolving oil-receptacle, having exit-spout at its lower end in contact with the packing of the box, substantially in the manner and for the purpose specified.

2. The combination of the car-axle box B, having cylindrical extensions B¹ B² and top channel B³ with a flanged revolving oil-receptacle C, having exit-spout C', passing in through the top channel, substantially in the manner and for the purpose specified.

3. The combination of the car-axle box B, having extensions B¹ B² and top channel B³, with the extension-flange *b* of the oil-receptacle and fastening-bolt D, to lock the oil-receptacle securely in position, substantially as specified.

4. The combination of the car-axle box, having extension B¹ B² and top channel B³, with entrance-hole *d* of a revolving oil-receptacle, C, having exit-spout C', to admit filling of the same on withdrawing of fastening-bolt, substantially as specified.

RICHARD B. EASON.

Witnesses:

PAUL GOEPEL,
C. SEDGWICK.