

G. W. GRAHAM.

ALARM-LOCK.

No. 191,046.

Patented May 22, 1877.

Fig: 1.

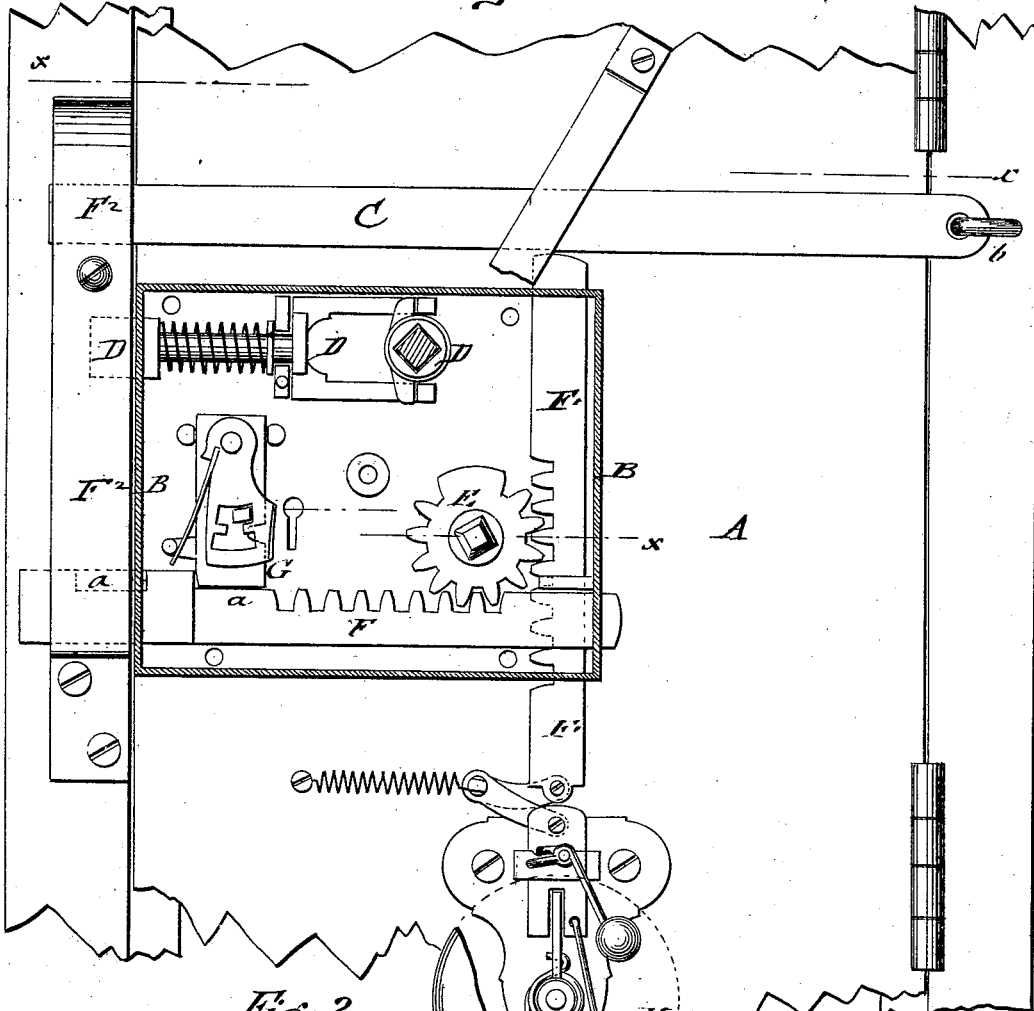

Fig: 2.

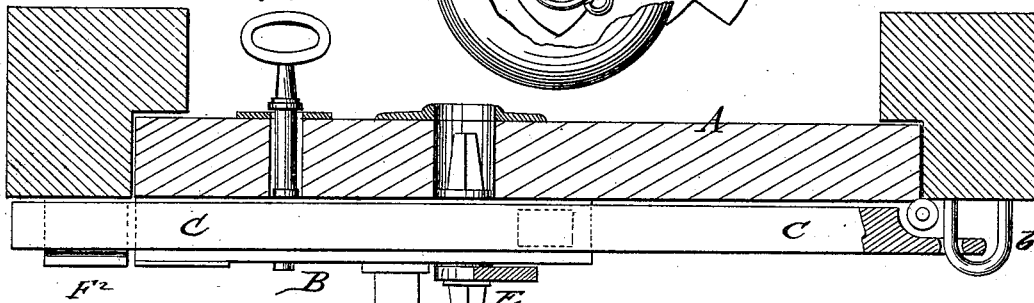
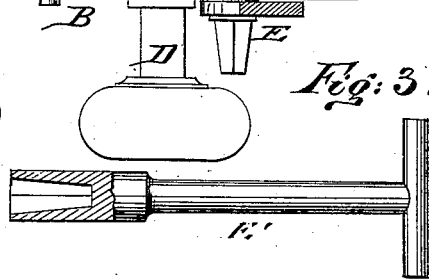

Fig: 3.



WITNESSES:

Chas. Nida.
A. J. Terry.

INVENTOR:

G. W. Graham
BY *Mumford*
ATTORNEYS.

UNITED STATES PATENT OFFICE.

GEORGE W. GRAHAM, OF GRAND JUNCTION, TENNESSEE.

IMPROVEMENT IN ALARM-LOCKS.

Specification forming part of Letters Patent No. 191,046, dated May 22, 1877; application filed April 16, 1877.

To all whom it may concern :

Be it known that I, GEORGE W. GRAHAM, of Grand Junction, in the county of Harde- man and State of Tennessee, have invented a new and Improved Lock, of which the follow- ing is a specification :

In the accompanying drawing, Figure 1 represents a side elevation of my improved lock with parts cut off; Fig. 2, a horizontal section of the same on line *x x*, Fig. 1; and Fig. 3, a detail view of the additional key re- quired.

Similar letters of reference indicate corre- sponding parts.

The object of this invention is to provide an improved combination bar and bolt-lock, that secures the door in strong and reliable man- ner; and the invention consists of toothed bolts, moving at right angles to each other when engaged by a cog-wheel turned by a key after the common spring-bolt is withdrawn. The vertical bolt lifts the cross-bar and rings a bell on opening.

In the drawing, A represents a door, which is provided with a lock, B, and a strong cross- bar, C, that serve jointly to lock the same.

The lock B is provided with a common knob-bolt and knob, D, in the customary man- ner, for the purpose of opening and closing the lock for common use during the day.

A cog-wheel, E, of the lock is turned by a suitable key, E', fitting on the square center- pivot of the same, and is made to gear with the toothed bolts F F', of which the bolt F slides in horizontal, the other bolt or bar, F', in vertical, direction, they being both guided in suitable manner in the lock-casing.

The cog-wheel E is so placed near the point of crossing of the bolts F F' that both are en- gaged at the same time, one being drawn back and the other lifted, so as to withdraw bolt F from its retaining-plate F², and raise cross-bar C out of the upper part of the plate F² high enough to clear the same, for admit- ting the opening of the door.

The horizontal bolt F' is provided with re-

cesses *a*, into which an ordinary key-bolt, G, locks, for retaining the bolt in open as well as closed position, the key-bolt G retaining, at the same time, the upright bolt F' in raised or lowered position by means of the inter- meshing cog-wheel E.

The lifting bolt or bar F' is connected, by a sliding and spring-acted joint, with a bell de- vice, H, that is operated simultaneously with the opening of the bolts, so as to give a bell- signal.

The lock and cross-bar are operated in easy manner by two keys—a common key for with- drawing the key-bolt G, and a second key, E', for operating jointly the lock-bolt F and cross-bar lifting-bolt F'. The cross-bar C is hung by an end hole to a staple, *b*, of the door-casing, to swing readily thereon when raised.

When the bolt F is drawn back and the cross-bar lifted the key-bolt is dropped into the second recess, *a*, of bolt F', so as to retain the bolts in open position. The door is locked and barred from the outside by the two keys, and thereby a strong and effective, yet simple and quickly-operated, lock con- struction furnished.

Having thus described my invention, I claim as new and desire to secure by Letters Patent—

1. The combination of toothed bolts F F', arranged at right angles to each other, with an operating cog-wheel, E, and cross-bar C, for simultaneously withdrawing or locking bolt F and raising or lowering cross-bar C, substantially as and for the purpose set forth.

2. The combination of the toothed bolt F, having recess *a*, and toothed upright bolt F', with a key-bolt, G, intermeshing cog-wheel E, and cross-bar C, to retain lock and cross-bar in open or closed position, substantially as specified.

GEORGE W. GRAHAM.

Witnesses:

N. S. PATTERSON,
N. H. PREUITT.