

J. GRAVES.
OIL-CAN.

No. 191,047.

Patented May 22, 1877.

Fig: 1.

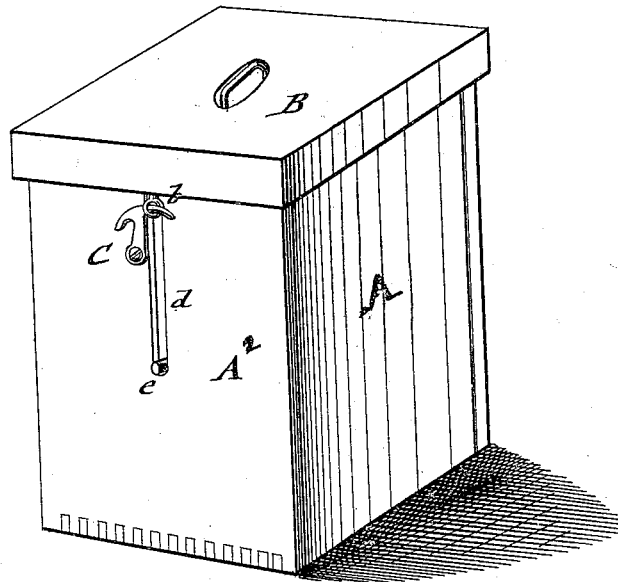
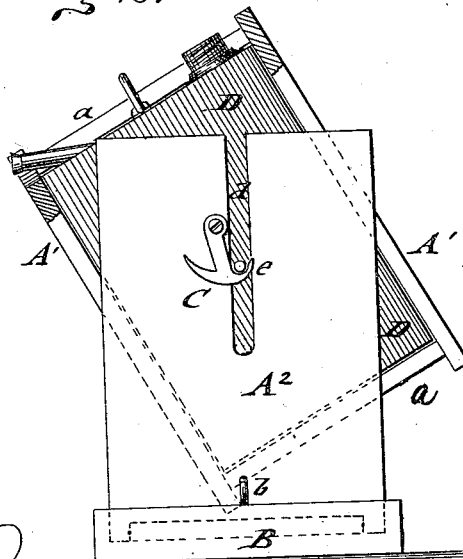

Fig: 2.



WITNESSES:

Cnas. Nica.
J. H. Scarborough.

INVENTOR:

BY *J. Graves.*
[Signature]
ATTORNEYS.

UNITED STATES PATENT OFFICE.

JOHN GRAVES, OF NEW YORK, N. Y., ASSIGNOR TO HIMSELF AND JAMES L. MILLER, OF WESTFIELD, NEW JERSEY.

IMPROVEMENT IN OIL-CANS.

Specification forming part of Letters Patent No. 191,047, dated May 22, 1877; application filed April 30, 1877.

To all whom it may concern:

Be it known that I, JOHN GRAVES, of the city, county, and State of New York, have invented a new and Improved Case for Oil-Cans, of which the following is a specification:

In the accompanying drawing, Figure 1 represents a perspective view of my improved case for oil-cans, showing the can boxed up; and Fig. 2, a side view of the same, showing the can in position for use.

Similar letters of reference indicate corresponding parts.

The invention has reference to an improved case for packing oil-cans for transportation, the case furnishing the additional facility that the can may be readily inserted into the same and tilted for use; and the invention consists of a wooden protecting-case with side slots, in which trunnions of the can are guided and supported for swinging the can on pivot-hooks, which serve also for the purpose of locking the lid to the case.

In the drawing, A represents a wooden protecting-case for shipping oil-cans of any desired size, the case being made of two sections, of which the inner section A¹ is attached by top cross-pieces *a* to two sides and the bottom of the can, while the outer sections A² cover the remaining sides, and has a connecting second bottom. The lid B completes the protecting-case and holds the sides of the outer section firmly to the can, which is taken hold of by a handle of the can, passing through a hole of the lid or to a level with the same. The lid is securely locked to the outer section A by means of double-pivot hooks C passing through staples *b* of the lid, as shown in Fig. 1. The sides of the outer section of the case are provided with slots *d*, that run down from the upper edge to suitable depth below the same, for the purpose of guiding side trunnions or pivots *e* of the can D when the same is lifted with the inner section A after the lid

is taken off. The pivot-hooks C drop by their own weight below the trunnions and support the can at such height above the bottom of the outer section that the can may be readily tilted into inclined position, for pouring out the oil through the spout directly into the lamps or other receptacles, as shown in Fig. 2. The lid is placed below the bottom of the outer section of the case when the can is in position for use, so as to be in connection therewith and not liable to get mislaid.

When the can is prepared for return shipment, the pivot-hooks are taken off the trunnions, and the can lowered down to the bottom of the outer sections, the lid being then replaced on the top of the case and locked by the hooks, the case inclosing thus the cans on all sides in reliable and safe manner, while admitting also the ready use of the can for drawing off the oil for use at any moment.

Having thus described my invention, I claim as new and desire to secure by Letters Patent—

1. A case for packing oil-cans for transportation, consisting of an inner section, A¹, attached by top cross-strips to can, of a detachable outer section, A², and of a lid, B, substantially in the manner described, and for the purpose specified.

2. The combination of the case A, having guide-slots and pivot-hooks C, with side trunnions of the can to support the same in raised position for tilting, substantially as specified.

3. The combination of the can D, having side trunnions, outer section A², having side slots, and pivot-hooks C, inner section A¹ attached to can, and lid B having staples for entrance of locking-hooks to secure case firmly to can, substantially as specified.

JOHN GRAVES.

Witnesses:

PAUL GOEPEL,
ALEX. F. ROBERTS.