

P. MEDART.  
BUNG CUTTING-MACHINE.

No. 191,066.

Patented May 22, 1877.

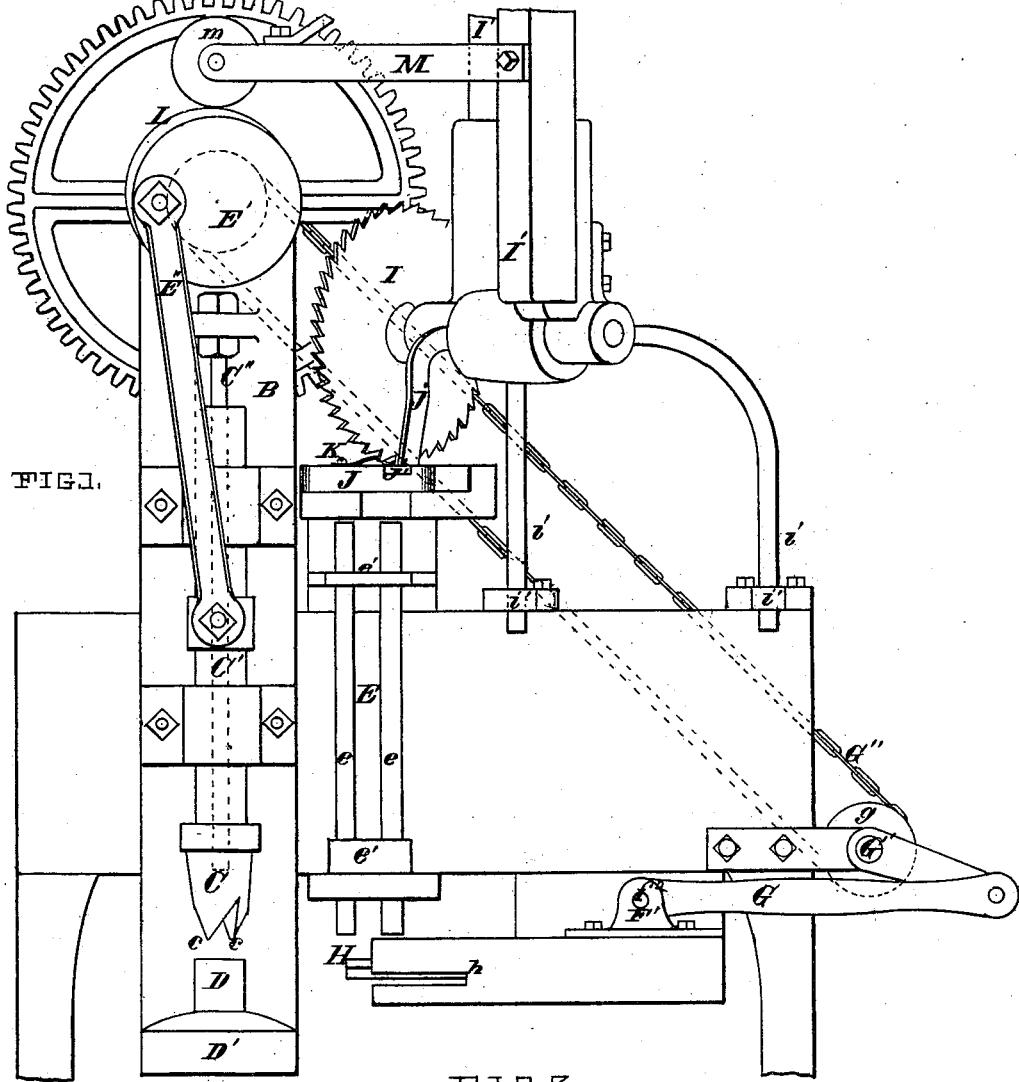

FIG. 1.

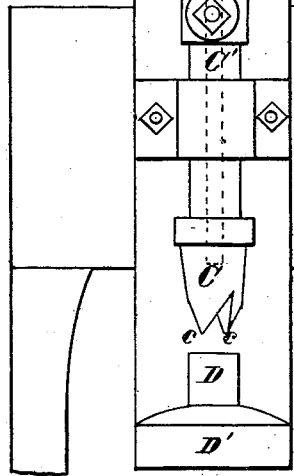

FIG. 4.

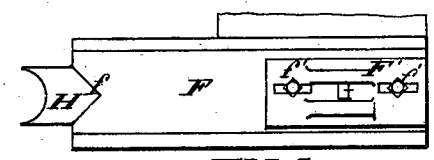
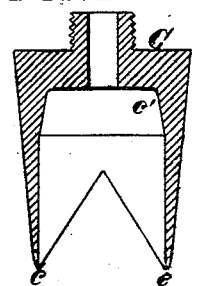

FIG. 3.

FIG. 5.



ATTEST.

INVENTORS.

*C. W. Stumm* *Philip Medart*  
*Paul R. Stange*

P. MEDART.  
BUNG CUTTING-MACHINE.

No. 191,066.

Patented May 22, 1877.

FIG. 6.

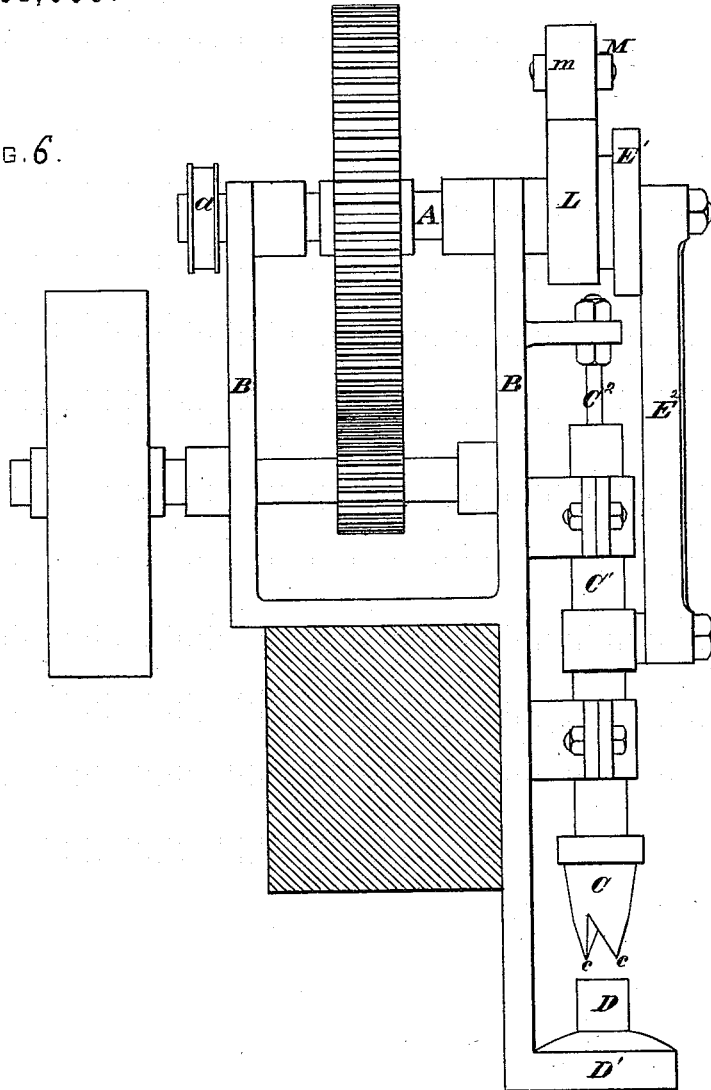

FIG. 7.

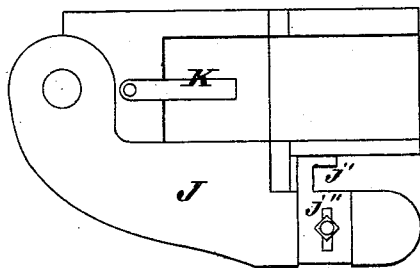
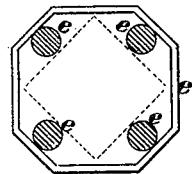

FIG. 8.



ATTEST,  
*C. W. Stemmet*  
*Paul R. Stange*

INVENTOR,  
*Philip Medart*

P. MEDART.  
BUNG CUTTING-MACHINE.

No. 191,066.

Patented May 22, 1877.

FIG. 8.

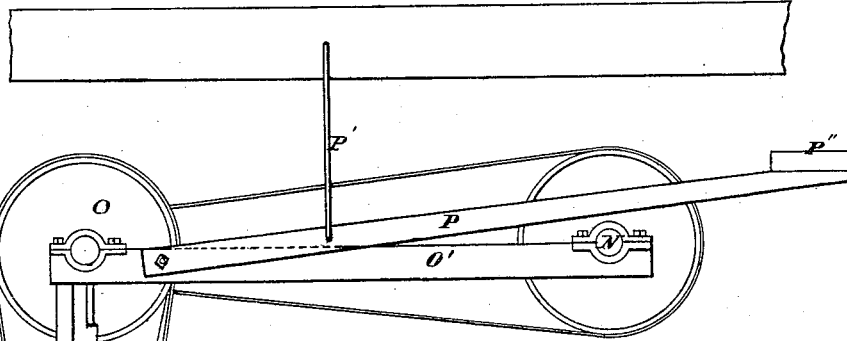

FIG. 10.

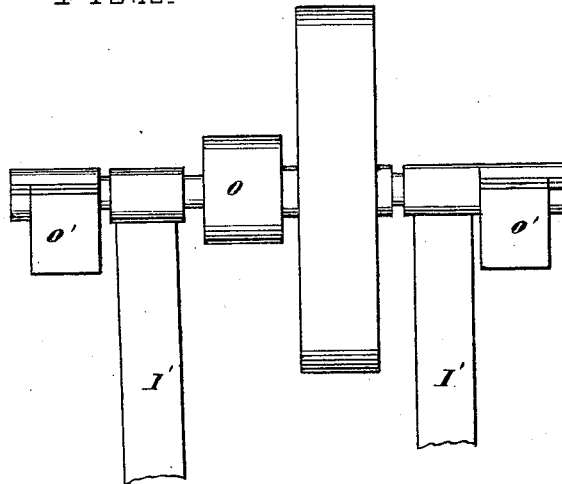
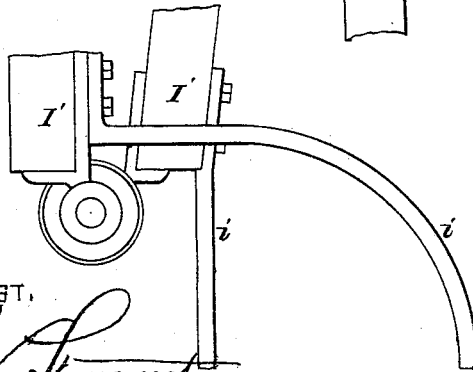

FIG. 11.



ATTEST.

*C. W. Semmes*  
*Paul A. Stange*

INVENTOR.

*Philip Medart*

# UNITED STATES PATENT OFFICE.

PHILIP MEDART, OF ST. LOUIS, MISSOURI, ASSIGNOR OF ONE-HALF HIS RIGHT TO FREDERICK MEDART, OF SAME PLACE.

## IMPROVEMENT IN BUNG-CUTTING MACHINES.

Specification forming part of Letters Patent No. 191,066, dated May 22, 1877; application filed January 17, 1877.

*To all whom it may concern:*

Be it known that I, PHILIP MEDART, of the city and county of St. Louis, and State of Missouri, have invented new and useful Improvements in Bung-Cutting Machines, which improvements are fully set forth in the following specification and accompanying drawings, in which—

Figure 1 is a front view of the machine. Fig. 2 is a top plan of feed-bar. Fig. 3 is a side elevation of feed-bar pitman. Fig. 4 is a detail vertical section of cutter. Fig. 5 is a detail vertical section of the die. Fig. 6 is an end elevation of the machine. Fig. 7 is an enlarged top view of the hopper. Fig. 8 is a cross-section of same. Fig. 9 is a side elevation of saw-driving mechanism. Fig. 10 is a detail end elevation of same. Fig. 11 is a detail side elevation of lower end of same.

A is the main driving-shaft, supported in bearings on the frame B, and carrying a crank-disk, E<sup>1</sup>, the pitman E<sup>2</sup> of which is connected to the sliding shank C<sup>1</sup> of the cutter C. D is the die on which the bung-blank rests while being cut. The die is supported on a bracket, D<sup>1</sup>, attached to the main frame B. E is the hopper for holding the squared blanks out of which the bungs are cut. This hopper consists of four metal rods or bars, e, having a light metallic casing, e', at top and bottom. The object of forming the hopper of bars e, as described, is to overcome the friction met with in a closed hopper, and thus admit of the blanks descending in the hopper with but little liability of binding therein. At the same time the blanks in the hopper can be manipulated by the operator, as the corners of the blanks project between the bars.

Beneath the hopper E is arranged a double feed-slide made in two parts, connected together so that they will have a limited motion independent of each other. The main slide F is provided with a bracket, F', to which is journaled the pitman G<sup>1</sup> of the operating crank-shaft G, carrying a pulley, g, which is driven by a chain or band, G<sup>2</sup>, extending from a pulley, a, on the main driving-shaft A. The front end of the slide F is formed with an angular notch, f, to receive the bung-blank

from the hopper E and push it onto the die D and under the bung-cutter C, to be formed into a bung. The bung-blank is carried on the secondary slide H, arranged to move with the slide F until it reaches the die D, when it became stationary, and the slide F advances far enough to push the blank on top of the die D, in position to be cut. On the back motion, both slides F H move together until the stop or shoulder h is reached, which holds the slide H stationary while the slide F moves back some distance so as to allow a new blank to drop down from the hopper E into the notch f, to be fed to the cutter on the movement of the machine.

The bracket F' is made adjustable by set-screws f<sup>1</sup> so as to allow the slide F to be adjusted to suit different sizes of blanks to be cut. The eye g' of the pitman G<sup>1</sup> is made open at bottom, and the rear edge rounded or inclined as shown, so that, on any derangement of the feeding mechanism, it will disengage itself from the pivot-pin f<sup>2</sup> of the slides, and thus prevent any liability to breakage of the parts. The cutter C is cylindrical in form, and its cutting-edge is formed with two projecting lips, c, which act to give a shearing cut to the bung with the grain of the wood, and thus prevent any liability of the bung being split in cutting. At its upper end the interior of the cutter C is formed with a bevel, c', corresponding to the desired shape of bung, so that, as the cutter C descends, the die D will force the cut bung up into said bevel, and compress the end of the bung into the desired shape. C<sup>2</sup> is a stationary plunger, which forces the bung out of the cutter C as said cutter ascends. The cutter C is made removable from its shank C<sup>1</sup> so as to allow of various-sized cutters being used, and the die D is made to receive a number of removable sleeves, D<sup>2</sup>, of Babbitt or other metal, corresponding in size with the cutter used.

The top of the die D is ornamented or lettered at d so as to impress the bungs as they are formed with letters or figures as desired. I is a circular saw arranged at the mouth of the hopper for cutting the bung. The saw-frame I' is guided vertically by guide-rods i i

sliding in guides *v v* secured to the frame B of the machine.

A vertical reciprocating motion is communicated to the saw-frame by a cam, L, on the main driving-shaft, which acts against a friction roller, *m*, on an arm, M, secured to the saw-frame.

Motion is communicated to the saw I from the countershafting N overhead, through an idler-pulley, O, the supporting-arms O' of which are pivoted to the countershafting N. To the shaft of this idler-pulley O is pivoted the frame I' of the saw I.

P is a counter-balance lever fulcrumed to link P', its inner end being pivoted to the arms O' while its outer end carries a counter-balance weight, P'', the purpose being to partially balance the weight of the saw-frame and other parts.

I claim as my invention—

1. The die D, having removable sleeves D<sup>2</sup>,

in combination with the cutter C, substantially as and for the purpose set forth.

2. The feeding-slides F H, having a motion independent of each other, substantially as set forth.

3. The driving-shaft A, pulley *a*, chain G<sup>2</sup>, and pulley *g*, in combination with the crank-shaft G<sup>1</sup>, pitman G, and feed-slide F H, substantially as and for the purpose set forth.

4. The hopper E, formed of bars *e*, substantially as and for the purpose set forth.

5. The vertical blank-hopper E, having a cut-off saw, I, arranged at its upper end, and a feed-slide, F, at its lower end, in combination with the cutter C and die D, substantially as set forth.

PHILIP MEDART.

Witnesses:

C. W. STEMMET,  
PAUL R. STANGE.