

H. BROOKE.

GLASS MOLD FOR SHADE-HOLDER AND SHADE.

No. 191,102.

Patented May 22, 1877.

Fig. 1.

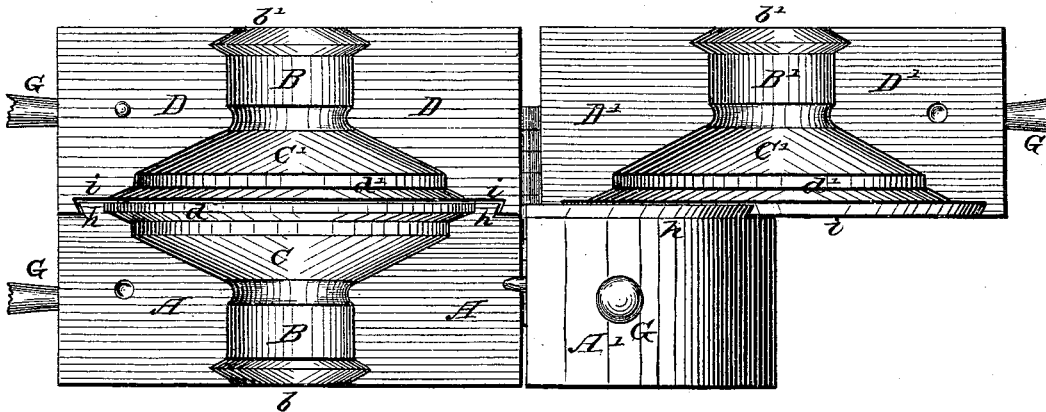
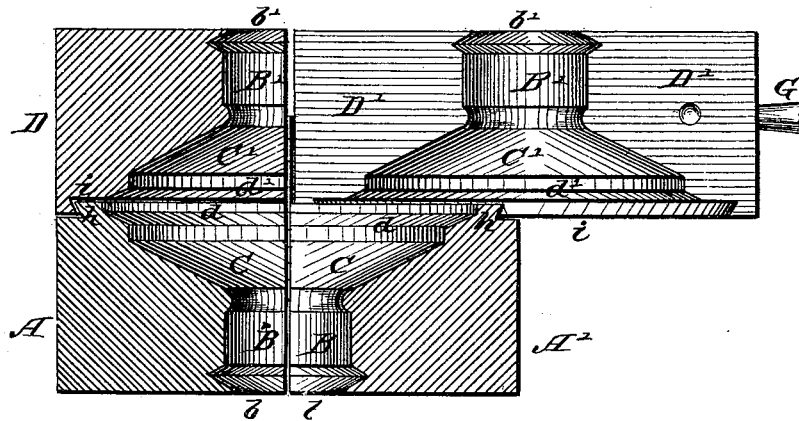

Fig. 2.



Witnesses:

P. C. Dieterich
Frank H. Duffy

Inventor:
Homer Brooke

Per: *C. A. Watson & Co.* Attorneys.

UNITED STATES PATENT OFFICE.

HOMER BROOKE, OF BROOKLYN, NEW YORK, ASSIGNOR TO BENNETT B. SCHNEIDER, OF NEW YORK CITY.

IMPROVEMENT IN GLASS-MOLDS FOR SHADE-HOLDERS AND SHADES.

Specification forming part of Letters Patent No. 191,102, dated May 22, 1877; application filed January 20, 1877.

To all whom it may concern:

Be it known that I, HOMER BROOKE, of Brooklyn, in the county of Kings and State of New York, have invented certain new and useful Improvements in Molds for Shade-Holders and Shades; and I do hereby declare that the following is a full, clear, and exact description thereof, that will enable others skilled in the art to which it appertains to make and use the same, reference being had to the accompanying drawings, and to the letters of reference marked thereon, which form a part of this specification.

My invention relates to molds for shades; and it consists in the construction of a compound mold having a "blow-over" in the center and at the top and bottom, whereby two shades may be blown at the same time, and afterward easily separated, as will be hereinafter more fully set forth.

In the annexed drawing, which fully illustrates my invention, Figure 1 shows my compound mold open, and Fig. 2 is a vertical section of the same closed.

My compound mold is composed of four parts, exactly alike in construction, the two top parts being reversed on top of the bottom parts.

A A' represent the two lower parts, constructed to form an inverted shade—that is to say, in the center, at the bottom, is the cylindrical part B, forming the top of the shade, and in the top is the cavity C, for forming the body of the shade.

At the lower end of the cylindrical aperture B is formed the circumferential groove *b*, which forms what is called by glass-blowers the "blow-over." Around the upper edge of the cavity C, in the molds A A', is formed a beveled offset, *d*, which also constitutes a blow-over.

The upper molds D D' are constructed in the same manner, with cylindrical aperture B', cavity C', and blow-overs *b'* and *d'*, and inverted on top of the lower molds A A', so that when closed the blow-overs *d* and *d'* coincide with each other, as shown in Fig. 2.

The four molds are provided with projecting handles G G.

On the upper faces of the bottom molds A

A' is formed an annular flange, *h*, having its outer side beveled or inclined; and on the lower faces of the upper molds D D' is formed a corresponding flange, *i*, to fit around the flange *h* when the molds are closed, thus forming proper stops and connections between the two sets of molds.

In making shades, in blowing the same into a mold, where a single shade is blown, it is necessary that the blow-over covers the entire bottom, so that the air is confined in order to expand the material to the sides of the mold, and when taken from the mold this blow-over must necessarily be broken and wasted.

The blow-over is also necessary, in order to produce the thin edge required on the outer expanded part, which also necessitates a waste of material.

This invention presents two important improvements: First, by blowing two shades in reversed form into a mold, and leaving a portion between the two expanded parts, for the purpose of separation, the two shades can be separated by a slight jar, or otherwise, leaving the outer edge as required, and with little or no waste to be broken off in the blow-over, thus saving material; and, secondly, two shades can be produced by this process as quickly as one, thus making a saving in time, and using about the same quantity of material in making the two, as heretofore used in making one.

In glass-blowing, compound molds have been used, but principally for blowing cylindrical articles, where the glass can be inserted from one side of the mold.

In using my compound mold, the lower molds A A' are closed, and the top molds D D' thrown open. The blower places his glass, in the form of a half-blown globe, on top of the bottom molds, which form a resting-place for the same, and presses down on the glass, so as to half-fill the cavity C, more or less. The top molds D D' are then closed, and the blowing completed within the entire closed mold, and the glass will be of uniform thickness throughout, which it would not be if the glass were inserted from one side.

Having thus fully described my invention,

what I claim as new, and desire to secure by Letters Patent, is—

A compound mold for shades, having a blow-over in the center and at the top and bottom, whereby two shades may be blown at the same time and afterward easily separated, substantially as herein set forth.

In testimony that I claim the foregoing I have hereunto set my hand this 17th day of January, 1877.

HOMER BROOKE.

Witnesses:

C. N. BONER, Jr.,
JOSHUA M. FIERO.