

W. C. DAVIS.
OVEN AND OVEN-DOORS.

No. 191,119.

Patented May 22, 1877.

Fig. 1

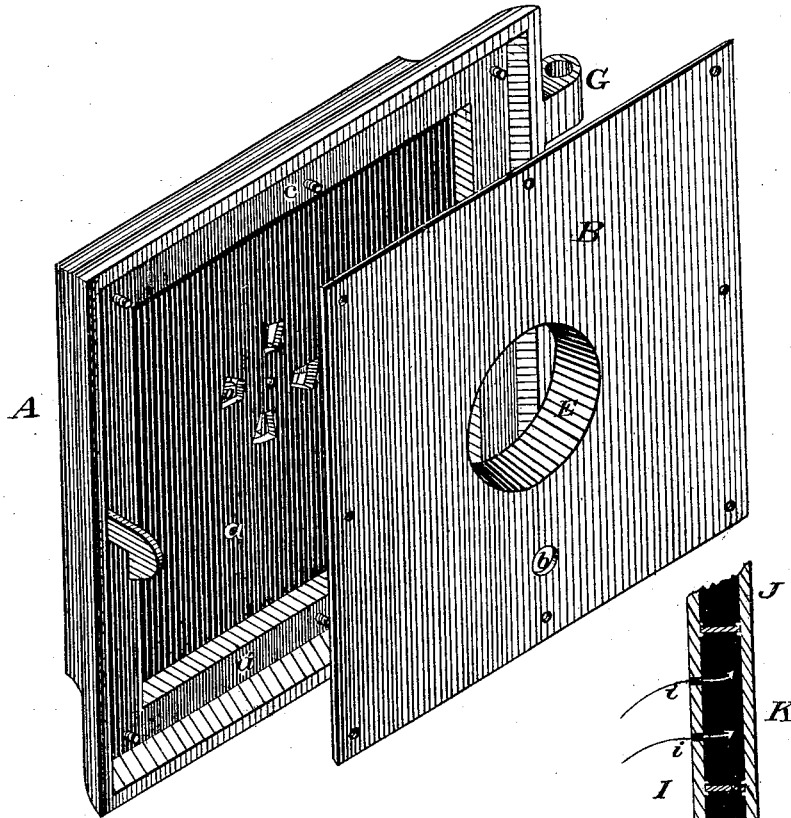
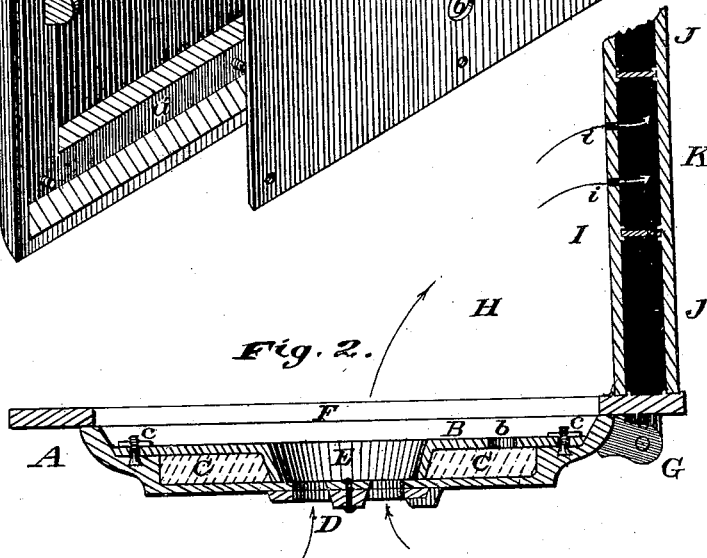

Fig. 2.



Attest
Walter Knight
S.M. Bond

Inventor.
William C. Davis
By T. Knight
Atty.

UNITED STATES PATENT OFFICE

WILLIAM C. DAVIS, OF CINCINNATI, OHIO, ASSIGNOR TO W. C. DAVIS & CO., OF SAME PLACE.

IMPROVEMENT IN OVENS AND OVEN-DOORS.

Specification forming part of Letters Patent No. 191,119, dated May 22, 1877; application filed December 27, 1876.

To all whom it may concern:

Be it known that I, WILLIAM C. DAVIS, of Cincinnati, Hamilton county, Ohio, have invented a new and useful Improvement in Oven-Doors and Ovens of Cook-Stoves and Ranges, of which the following is a specification:

The importance of retaining the heat in the oven of a stove or range is well known, and efforts have been made to accomplish this by lining the oven-doors with "tin" or sheet-metal plates, all of which expedients have failed to accomplish the object, as these linings, being good conductors of heat, have offered little or no obstruction to the loss of heat through the doors. I do not claim merely lining an oven-door, as I am aware that that has been previously done. My invention relates to the use of a non-conducting material therefor that will prevent loss of heat from the oven.

In all diving-flue stoves and ranges the upper part of the oven is heated to a greater degree than any other portion of it, for the reason that the heat from the fire-chamber is in close contact with it, causing the contents of the oven to burn on the top before being well cooked on the bottom. To have better control of the heat in the oven, and prevent the victuals from burning on top, I make a registered aperture through the oven-door, and small openings in the back flue-plate of the stove, opening into the flue near the pipe, so that when the register is opened a draft of air through it across the upper part of the oven to the openings in the flue will so temper the heat as to prevent the oven being overheated on top without affecting the temperature in the bottom of the oven.

In the accompanying drawing, Figure 1 is a perspective representation of the metallic portion of my oven-door in its preferred form. Fig. 2 is a horizontal section through the completed oven-door, together with portions of the side plate and rear flue-plates.

A represents the outer, and B the inner, plate of my improved form of oven-door. These plates I usually make of cast-iron. The outer plate A has on its rear side a re-

cess or chamber, *a*, surrounded by a ledge or rabbet, *a'*, which rabbet supports the inner plate B. The plate B has an orifice, *b*, for the introduction of plaster-of-paris C while in a liquid condition after the said plate has been permanently secured in place upon the outer plate A, as shown in Fig. 2.

A registered aperture, D, may be provided in the plate A, and the inner plate B may be correspondingly perforated and provided with a neck or collar, E, for the purpose of admitting cool air where it is desired to equalize the heat in different parts of the oven by cooling the upper portions.

The plates A and B being secured together by screws *c* or other suitable means, plaster-of-paris in a semi-liquid condition is introduced through the orifice *b*, so as to completely fill the chamber *a*, and to envelope the neck E in a solid mass of non-conducting material.

F represents the side plate of a cook-stove, to which the door is attached by hinges G in the usual manner. H is the oven-space. I is the rear plate of the oven, forming the front wall of a set of customary diving and exit flues, J, J', and K. That portion of the plate I which incloses the exit-flue K has one or more orifices, *i*. Should the oven be in danger of becoming overheated in its upper portion, that heat may be reduced, and the temperature of the different portions of the oven be equalized by opening of the register to a greater or less extent, so as to permit cool air from without to traverse the oven in its passage from the register to the said flue-openings.

I am aware that the doors of furnaces and the outer casings of stoves and heaters have been composed, in whole or part, of refractory or non-conducting materials, and therefore make no claim to such devices, broadly considered.

I claim as new and of my invention—

1. A door for ovens of stoves and ranges composed of two thicknesses of metal, A, inclosing a cavity or chamber, *a*, which is filled with plaster-of-paris C, or equivalent non-conductor.

2. An oven-door composed of the registered and perforated plates A *a a'* D and B *b b'* E, inclosing a filling of plaster-of-paris or equivalent non-conductor.

3. The described combination of composite and registered oven-door A *a a'* D B *b b'* E, oven H, and perforated rear oven-plate I *i*, for the purpose designated.

In testimony of which invention I hereunto set my hand.

W. C. DAVIS.

Attest:

GEO. H. KNIGHT,
WALTER KNIGHT.