

J. STANNAH.  
DONKEY-ENGINE AND PUMP.

No. 191,190.

Patented May 22, 1877.

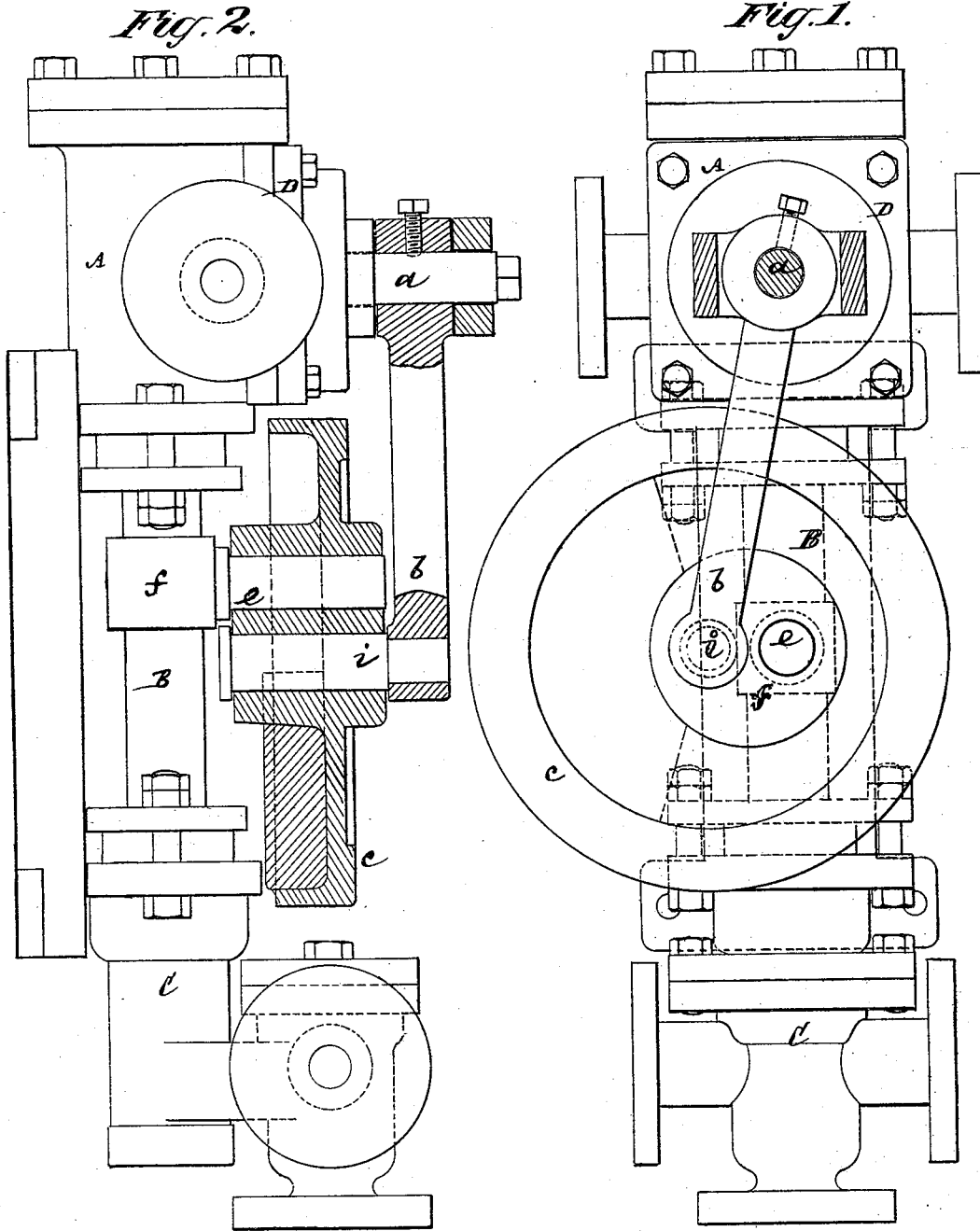

Witnesses.  
John Becker  
J. W. Haynes

Inventor  
Joseph Stanah  
By his Attorneys  
Brown & Allen

# UNITED STATES PATENT OFFICE

JOSEPH STANNAH, OF SOUTHWARK, ENGLAND.

## IMPROVEMENT IN DONKEY ENGINES AND PUMPS.

Specification forming part of Letters Patent No. **191,190**, dated May 22, 1877; application filed March 21, 1877.

*To all whom it may concern:*

Be it known that I, JOSEPH STANNAH, of Southwark, in the county of Surrey, England, engineer, have invented new and useful Improvements in Donkey Engines and Pumps, which improvements are fully set forth in the following specification, reference being had to the accompanying drawings.

This invention relates to improvements in actuating the valves of that class of steam-engines known as "donkey-engines" or pumps for supplying steam-boilers with water, and for other purposes, in which the piston-rod of the cylinder and the plunger of the pump are made in one piece; and in order that my improvements may be clearly understood and readily performed or carried into practice, I will proceed to describe the same, reference being made to the drawings hereto annexed, and to the figures and letters marked thereon.

The invention consists in a certain combination of a rotating and swinging disk or pendulum-weight with the valve-spindle and with an eccentric pin attached to the reciprocating piston-rod of the engine or pump, whereby a very simple and efficient means is provided for operating the valve of the engine or pump.

Figure 1 is a front elevation of a steam-pump having my invention applied, and Fig. 2 a partly-sectional side view of the same.

A is the steam-cylinder; B, the piston-rod of said cylinder and plunger of the pump C. D is the valve box or chest.

Attached to the valve-spindle *a* is a pendulous rod, *b*, the lower or swinging end of which carries a pin, *i*, on which is fitted, so as to be capable of freely turning, in concentric rela-

tion with said pin, a metal disk, plate, or pendulum-weight, *c*. This disk or weight *c* is eccentrically connected by a pin, *e*, with a cross head or block, *f*, on the piston-rod and pump-plunger F.

The operation is as follows: As the piston-rod F is operated, the pin *e* moves in a straight or axial line with said rod, and, by the eccentric relations of the pins *e* and *i*, the disk or pendulum-weight *c* is not only caused to be rotated on the pin *i* as a center of motion, but to be swung to and fro across the axial line of the piston-rod. This gives an easy and positive action to the valve, and reduces cost of construction as compared with a fly-wheel and main shaft having a fixed center common to both, and a connecting-rod for operating the valve actuated by said shaft or fly-wheel. Such combination of parts essentially differs from a mere pendulum-action for operating the valve.

I claim—

The combination of the rotating disk or pendulum-weight *c*, the concentric pin *i* on or with which said disk or weight rotates, the valve-spindle *a*, the pendulous rod *b* connecting said valve-spindle and pin *i*, and the eccentric pin *e*, attached to the reciprocating piston-rod F, and connected with the rotating and swinging disk or weight *c*, substantially as specified.

J. STANNAH.

Witnesses:

J. G. TONGUE,  
34 Southamption Buildings, London, W. C.  
CHAS. BERKLEY HARRIS,  
17 Gracechurch Street, London.