

E. E. BLINN.
BARREL-TRUCK.

No. 191,222.

Patented May 29, 1877.

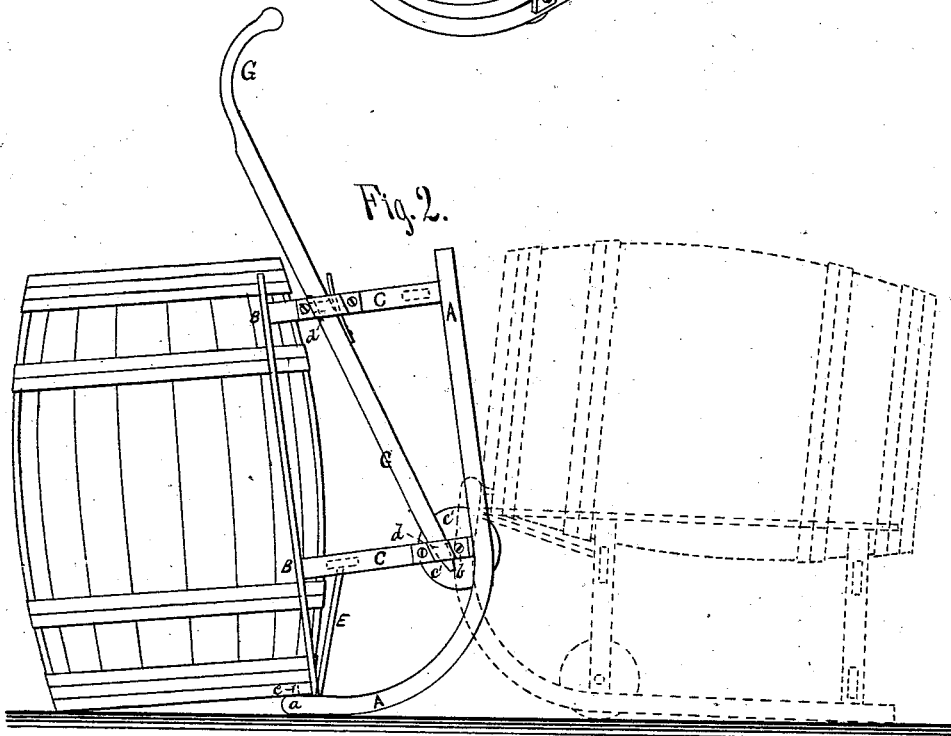
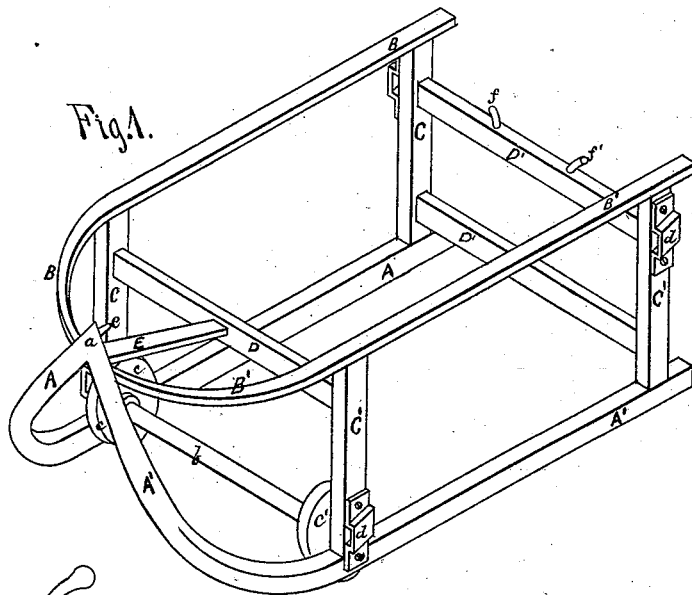

Witnesses.
C. W. Woodward
J. F. Orcutt.

Erastus E. Blinn
Inventor, By
Louis Feeser & Co. Attys.

UNITED STATES PATENT OFFICE.

ERASTUS E. BLINN, OF MINNEAPOLIS, MINNESOTA.

IMPROVEMENT IN BARREL-TRUCKS.

Specification forming part of Letters Patent No. 191,222, dated May 29, 1877; application filed April 13, 1877.

To all whom it may concern:

Be it known that I, ERASTUS E. BLINN, of Minneapolis, in the county of Hennepin and State of Minnesota, have invented certain new and useful Improvements in Barrel-Trucks, which improvement is fully set forth in the following specification and accompanying drawing, in which—

Figure 1 is a perspective view; Fig. 2, a side elevation, showing the method of operating it.

This invention relates to combined trucks and supporting-frames for barrels, &c.; and consists in a peculiarly-formed tilting frame, upon which the barrel or box is placed, and having two wheels, working independently of each other, by which the barrel may be easily moved about from place to place.

The invention further consists in attaching a pair of movable handles to the frame to assist in operating it.

A A' are the two side pieces or runners, which are bent upward and inward in a curved form, and are connected together at the center, at *a*, as shown. B B' are two top rails or fenders, which are bent around and connected to the runners A A' at the same point *a*. C C' are the uprights or posts which connect the upper and lower rails A B together, and D D' the cross-bars, which not only connect the sides together, but act as supports to the barrel. E is a brace, which supports and stiffens the frame at *a*. *b* is an axle, upon which two loose wheels, *c c'*, run, whose rims extend down below the bottoms of the runners A A', by which the frame may be moved about. *e* is a pin, set in the inside of the nose *a*, beneath which the chine of the barrel is set to hold it in place when the truck is tilted back. *f f* are two pins, placed in the upper rear cross-piece D', which serve to hold the barrel in place, and prevent its rolling. *d d'* are sockets, secured to the sides of the frame, in which the handles G G' are placed, as shown in Fig. 2.

By this arrangement I obtain a very light, strong truck, and by its curved form I gain an important advantage in point of leverage, as the curved front places the center of gravity near the center of the barrel, thus making it a very easy matter to tilt it backward.

I also claim a great advantage in arranging the wheels *c c'* to operate independently of each other, as by this means the truck may be much more easily turned about than if a solid roller was used.

The frame is so constructed that the front end of the barrel will be lower than the back end, so that all the liquid will be discharged.

Usually each barrel in use in a store will be provided with one of these trucks, but they will also be found very convenient to use as an ordinary truck in handling barrels, large boxes, &c.

I am acquainted with the patent of George M. Shepard, May 19, 1874, No. 150,979, for tilting trucks, who shows a solid-sided frame with the front only slightly curved upward, and two solid rollers by which to move it from place to place.

I do not claim the truck itself; but

What I claim as new, and desire to secure by Letters Patent, is—

1. The frame consisting of the runners A A', rails or fenders B B', bent upward and inward, and connected together at *a*, in combination with the wheels *c c'*, arranged and operating substantially as specified.

2. The frame A B and wheels *c c'*, in combination with the handles G G', arranged and operating substantially as shown and described.

In testimony whereof I have hereunto set my hand in the presence of two subscribing witnesses.

ERASTUS E. BLINN.

Witnesses:

C. N. WOODWARD,
EDWARD ROTERT.