

L. F. JEFFERSON.

ROAD-SCRAPER.

No. 191,287.

Patented May 29, 1877.

Fig. 1.

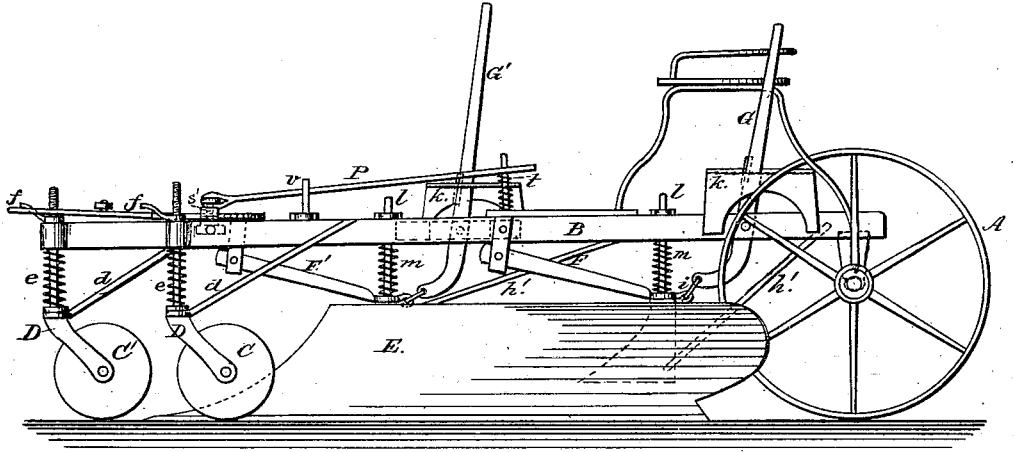
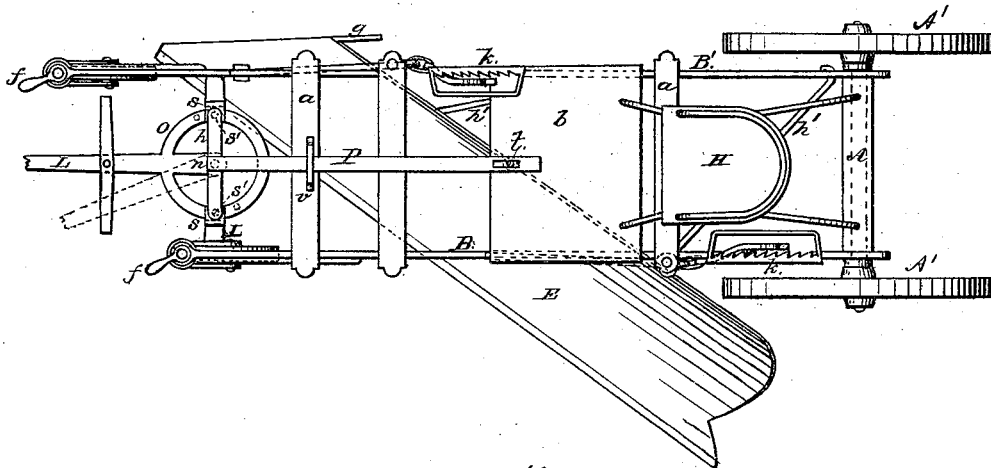

Fig. 2.



Witnesses:  
W. S. Bond  
M. Stanton

Liberty F. Jefferson Inventor:

# UNITED STATES PATENT OFFICE

LIBERTY F. JEFFERSON, OF MONMOUTH, ILLINOIS.

## IMPROVEMENT IN ROAD-SCRAPERS.

Specification forming part of Letters Patent No. 191,287, dated May 29, 1877; application filed May 8, 1877.

*To all whom it may concern:*

Be it known that I, LIBERTY F. JEFFERSON, of the city of Monmouth, county of Warren, and State of Illinois, have invented an Improved Machine for Grading and Cleaning Roads, of which the following is such a full, clear, and exact description, as will enable others to make and use the same, reference being had to the accompanying drawings, and to the letters of reference marked thereon, similar letters indicating corresponding parts in the different figures.

The object of this invention is to provide a convenient, cheap, and expeditious means for grading new roads, or scraping and regulating the surface of old ones, as well as to cut and clear it of grass and weeds; and the invention consists in certain details of construction and the arrangement of parts, which will be first fully described, and then specifically pointed out in the claims.

Figure 1 is a side view of the machine, and Fig. 2 a plan showing the relative position occupied by the scraper to the rest of the machine.

The axle A, which is carried by wheels A' A' at each end, supports the rear end of the side pieces of the frame, B and B', which are united and held in position by cross-pieces a a and platform b. The front end of the frame is carried upon a pair of trailing or caster wheels, C C'. The standards D rest in a bearing at the end of the side pieces, and in another formed in the extremity of the flexible brace d. Between these bearings the standards are surrounded with spiral springs e, which, in connection with the flexible braces, carry the load and accommodate the scraper to the unevenness of the road. A screw-thread is formed upon the end of each of the standards D, which are provided with a hand-nut, f, by turning which the forward end of the side pieces of the frame are raised or lowered to adjust them to different cuts.

Suspended beneath the frame, and occupying a diagonal position in relation thereto, is the scraper E, which is preferably formed of sheet-steel, in the shape of a longitudinally-extended plow mold-board, its lower edge, however, being perfectly straight and sharp from end to end. It is provided with

a short land-side, g, occupying a position parallel to the frame. This mold-board or scraper is adjustably suspended from the frame by means of the links h' and the adjusting devices, which consist of the lever F and F', pivoted to the side pieces of the frame at one end, and connected to the scraper E at the other.

Links i connect these levers with the lower extremities of the curved hand-levers G and G', the upper ends of which pass through rack-guides k k, that are secured to the side pieces of the frame.

Rising vertically from the scraper at its points of attachment to the levers F and F' are the guide-rods l, which pass upward through orifices in the ends of the cross-pieces a a, and are encircled by the spiral springs m', which press upon the scraper and allow it to jump upward upon striking slight obstructions, although they present no obstacle to the adjustment of its height relatively to the frame of the machine, which may be done by means of the hand-levers G and G', the first of which adjusts the rear and the other the front end of the scraper.

A seat, H, for the driver is placed upon the machine in such a position as to place both adjusting-levers within his reach, thus enabling him to control the movements and work of the machine without other help.

Crossing the machine near its front end is a rock-bar, I, to which the tongue L is attached by means of the pivot-pin n. A circle-plate, O, is also secured to the tongue, and turns with it about the pin n, being further guided by guides s, attached to the rock-bar. This circle is pierced with two holes, which, when the tongue is longitudinally in line with the rest of the machine, come opposite to corresponding holes in the guides s.

A spring-foot-lever, P, is provided at one end with the cross-bar p, and having two pins projecting from its under side, at such distance apart as to enter the holes in the guides s when the tongue and circle are in the proper position to hold the tongue rigidly in line with the machine when it is moving forward and in a straight line; but when it is desired to turn the machine, the operator places his foot upon the end of the spring-lever P near-

est to him, and as this end of the lever is supported by the spring *t*, while it is supported at mid-length by the slotted fulcrum *v*, it is evident that, upon depressing the end of the lever nearest to him, the opposite end will be raised and the pins withdrawn from the holes in the circles and guides, allowing the tongue to turn freely upon the pin *n*, and the team to be used in a direct pull for turning the machine, instead of a side pressure upon the tongue to accomplish the purpose.

As it seldom occurs that the machine is required to be turned in more than one direction, and in order to get the team as near as possible to the work, one of the side pieces of the frame is made shorter than the other, and the turning is done in the direction of the short side piece, which, in the present machine, is indicated by the letter B.

I am aware that a machine has heretofore been constructed and used embracing some of the general principles of the one here described, but having its details of construction so crudely carried out as to be almost inoperative.

Having thus described my invention, I claim as new, and desire to secure by Letters Patent, the following:

1. In a road grading and cleaning machine, the side pieces B and B', one of them shorter

than the other, for the purpose described, in combination with the cross-pieces *a* and platform *b*, as set forth.

2. The trailing or caster wheels C and C', carried by the adjustable vertical screw-threaded standards D, with springs *e*, in combination with the side pieces B and B' of the machine-frame and flexible supports *d*, as and for the purposes set forth.

3. The rocker-bar I, provided with guides *s*, in combination with the tongue L, fifth-wheel or circle, and lever P, provided with the cross-bar *h* and pins *s'*, for securing and releasing the tongue, as specified.

4. The scraper E, in combination with the supporting-links *h'*, guide-rods *l*, and springs *m*, as and for the purposes set forth.

5. The scraper E, in combination with the levers F and F', guide-rods and springs *m*, links *i*, hand-levers G and G', and rack-guides *k*, all constructed and arranged substantially as and for the purpose specified.

6. A road-scraper consisting of the frame B B', supported on wheels A' A' and spring caster-wheels C C', constructed and arranged substantially as set forth.

LIBERTY F. JEFFERSON.

Witnesses:

W. G. BOND,

W. H. SEXTON.