

D. BEST.
WASHING-MACHINE.

No. 191,301.

Patented May 29, 1877.

Fig. 1

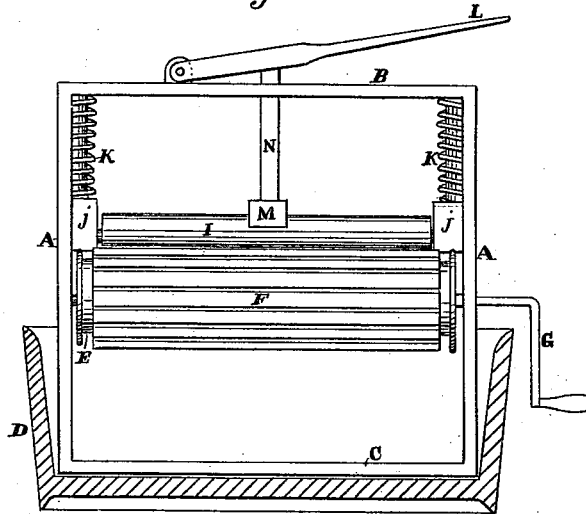
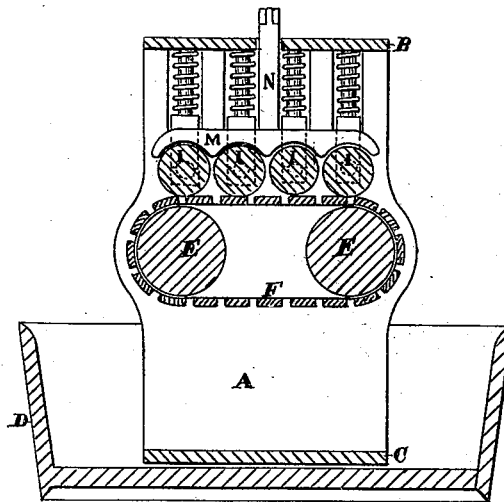

Fig. 2.



Witnesses
Geo. H. Strong.
J. W. L. B. B. B.

Inventor
Daniel Best
by Newey & Co.
Atty.

UNITED STATES PATENT OFFICE.

DANIEL BEST, OF AUBURN, OREGON.

IMPROVEMENT IN WASHING-MACHINES.

Specification forming part of Letters Patent No. **191,301**, dated May 29, 1877; application filed March 15, 1877.

To all whom it may concern:

Be it known that I, DANIEL BEST, of Auburn, county of Baker, and State of Oregon, have invented an Improved Washing-Machine; and I do hereby declare the following to be a full, clear, and exact description thereof, reference being had to the accompanying drawings.

My invention relates to an improved washing-machine; and it consists in combining an endless rubbing-belt with two or more pressing-rollers, which are arranged above the belt, all as hereinafter described.

Referring to the accompanying drawings, Figure 1 is a side view of my washing-machine. Fig. 2 is a vertical section of the same.

A A represent the sides, and B C the top and bottom, of a frame, which is constructed of the proper size to fit snugly inside of a tub, D. Inside of this frame I mount two horizontal rollers, E E, in the same plane, midway between the top B and bottom C of the frame. These rollers are placed as far apart as the width of the side boards A A will permit, and their journals bear in the sides of the frame, as represented. Around these rollers I place an endless slat-belt, F, the upper surface of which, between the rollers E E, will be horizontal. A crank, G, is applied to one of the journals of the rollers E, so that by turning the crank the rollers will be caused to rotate, and the endless belt to travel around them. Directly above the upper horizontal surface of the endless belt I mount a series of small rollers, I I I, parallel with each other. The journals of these rollers bear in sliding boxes *jj*, which move vertically in suitable grooves in the sides of the frame. A spiral spring, K, is interposed between each sliding box and the top of the frame, so that each roller will exert an independent pressure upon the upper surface of the moving belt.

To provide for increasing the pressure of the rollers I I upon the belt I place a brake-bar, M, across the rollers, and connect its

middle with a hand-lever, L, by means of an upright bar, N. One end of the lever is pivoted to the top of the frame, and the connecting-bar N passes up through the top of the frame, and is connected with the lever between the pivot and handle, so that by pressing down upon the handle of the lever any desired amount of pressure can be applied through the brake-bar upon the rollers.

When in use I secure the frame inside of the tub D. The clothes to be washed are taken singly and introduced between the endless belt and the rollers, and the endless belt set in motion by turning the crank G. The clothes are drawn between the endless belt and rollers, when, by applying the brake M, the rotation of the rollers will be retarded, while the endless belt continues to travel, thus holding and rubbing the clothes in a manner very similar to hand-rubbing. The clothes are also squeezed between the belt and rollers, so that the dirty water is expressed, thus preparing them to receive a fresh saturation after they drop into the tub again.

With this machine I am able to wash articles of all sizes, from the smallest pieces of lace to the largest blankets.

Having thus described my invention, what I claim, and desire to secure by Letters Patent, is—

In combination with the endless slat-belt F, mounted as described, the series of pressing-rollers I I I, each of which is mounted in independent slides *jj*, and pressed downward by a spring, K, and the brake-bar M, applied to said rollers by means of the lever L, and connecting-bar N, substantially as and for the purpose described.

In witness whereof I have hereunto set my hand and seal.

DANIEL BEST. [L. s.]

Witnesses:

JOHN C. NICKELS,
D. T. COLE.