

D. W. HOSHALL.

TARGETS FOR SHOOTING-GALLERIES.

No. 191,345.

Patented May 29, 1877.

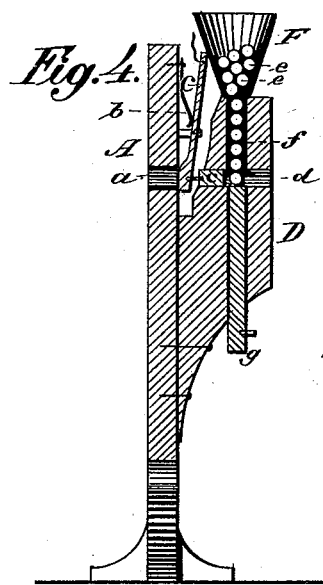
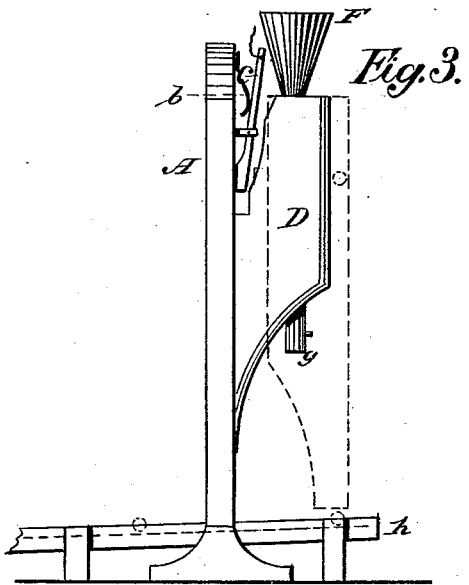
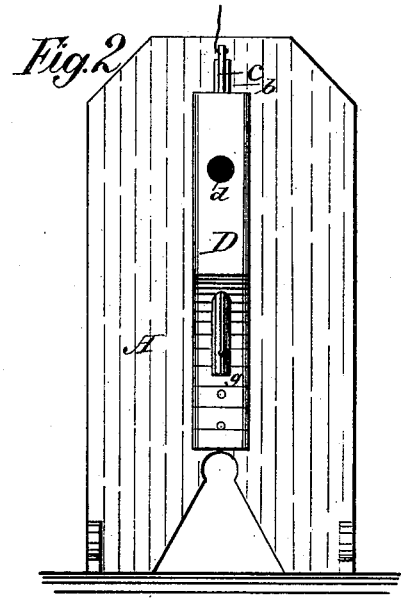
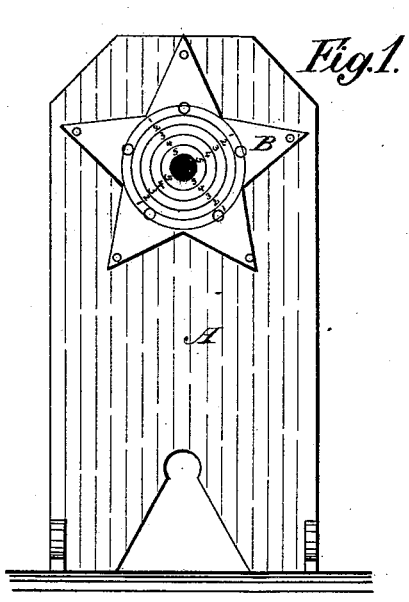

Attest:
E. E. Court
Jno. P. Brooks

Inventor:
David W. Hoshall
by Louis Baggett Co.
Attys.

UNITED STATES PATENT OFFICE.

DAVID W. HOSHALL, OF DALLAS, TEXAS.

IMPROVEMENT IN TARGETS FOR SHOOTING-GALLERIES.

Specification forming part of Letters Patent No. 191,345, dated May 29, 1877; application filed March 6, 1877.

To all whom it may concern:

Be it known that I, DAVID W. HOSHALL, of Dallas, in the county of Dallas and State of Texas, have invented certain new and useful Improvements in Targets for Shooting-Galleries; and I do hereby declare that the following is a full, clear, and exact description thereof, which will enable others skilled in the art to which it appertains to make and use the same, reference being had to the accompanying drawings, which form a part of this specification, and in which—

Figure 1 is a front view. Fig. 2 is a rear view. Fig. 3 is a side elevation, and Fig. 4 is a vertical transverse section.

Similar letters of reference indicate corresponding parts in all the figures.

This invention relates to targets for shooting-galleries; and it consists in the arrangement and combination of parts hereinafter described, by which a record of all center shots may be kept by the contestants themselves, for the purpose of deciding who are entitled to premiums, if any are to be awarded.

The construction and operation of my improved target are as follows:

A is the structure of planks upon which the target B is secured. The center or bull's-eye of the target is perforated, and the structure A has, behind the center of the target, a perforation, *a*, the diameter of which is equal to or, if desirable, larger than that of the center. The perforation or channel *a* is preferably lined with sheet metal, in order to prevent the wood-work from being injured by the balls.

To the rear side of the structure A is hinged a lever, C, made preferably of iron or other hard metal. Its lower end covers the perforation or channel *a*, against which it is kept by a suitably-arranged spring, *b*. To its lower rear side is pivoted a plunger, *c*, which operates in a horizontal perforation, *d*, in a block, D, of wood or other suitable material, which is secured upon structure A, as shown. The horizontal perforation *d* is crossed by another vertical perforation, *f*, the lower part of which is stopped by an adjustable rod, *g*. A hopper, F, leading into channel *f*, is secured on top of block D, and the rod *g* is, when my invention is to be put into operation, placed in

such a position that the channel *d* shall be open and level.

In the hopper F, I place a number of balls, *e*, made of wood, metal, rubber, or other material. These balls should be of a diameter somewhat less than that of channels *d f*, through which they are to pass. The lowermost of the balls *e* will fall through channel *f* into *d*, where it rests on top of rod or plug *g*. The rest of the balls occupy the lower part of the channel *f* and the hopper. Now, whenever a center shot is made, the ball, passing through channel *a*, will force the lever C backward, thus causing the piston or plunger *c* to force the lowermost ball *e* out through perforation *d*, from which it falls into a gutter, *h*, which carries it to the front of the shooting-gallery. The action of spring *b* instantly forces lever C back into its original position, thus allowing another ball to drop down into channel *d*, when the apparatus is again ready for action.

The lever C may, if desirable, be furnished with a pivoted pin extending through perforation *a* to the target, and serving as a center-pin; but this is not necessary. Its upper end may, also, by a string of wire or otherwise, be connected to a gong or bell, which will thus be sounded every time a center shot is made; or it may be made to operate a registering-dial for counting the total number of center shots; or it may be connected to and made to operate any other suitable device without changing the nature of my invention.

In order to show my invention out of operation it is only necessary to raise the rod or plug *g* far enough to prevent any balls from dropping into channel *d*, when the shooting may go on without the center shots being registered.

The balls *e* may, when desirable, be painted in different colors or numbered, or both, (in the same manner as billiard pool-balls,) when the color or number, or both, of the various balls may be made to determine who shall be entitled to the premiums offered for the center shots, in accordance with any plan previously agreed upon.

Having thus fully described my invention, I claim and desire to secure by Letters Patent of the United States—

1. The combination of structure A, having target B, and perforation *a*, pivoted lever C, having plunger *c*, and spring *b*, substantially as and for the purpose herein shown and specified.

2. The block D, having channels *d f*, adjustable plug *g*, and hopper F, in combination with the pivoted lever C, having piston or plunger *c*, for impelling the balls *e e* previously placed in hopper F, substantially as

and for the purpose herein shown and specified.

In testimony that I claim the foregoing as my own I have hereto affixed my signature in presence of two witnesses.

DAVID W. HOSHALL.

Witnesses:

JACOB WAGNER,

JACOB DENNIS.