

J. NAYLOR.

ATTACHING KNOBS TO SPINDLES.

No. 191,363.

Patented May 29, 1877.

Fig. 1.

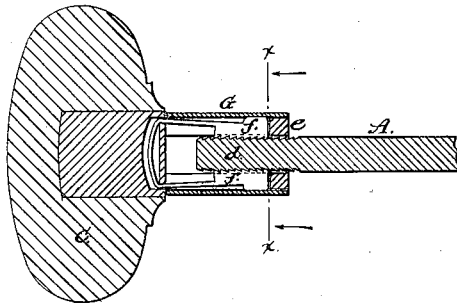

Fig. 2.

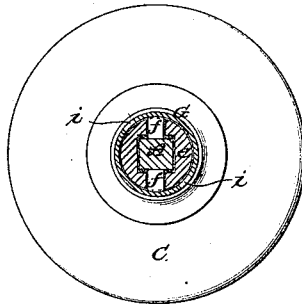
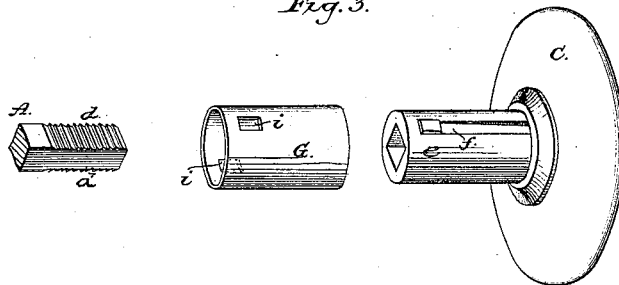

Fig. 3.



Witnesses:

Geo. H. Graham

Jacob Selby

Inventor:

Joseph Naylor
By attorney,
J. M. Peters

UNITED STATES PATENT OFFICE.

JOSEPH NAYLOR, OF NEW YORK, N. Y.

IMPROVEMENT IN ATTACHING KNOBS TO SPINDLES.

Specification forming part of Letters Patent No. **191,363**, dated May 29, 1877; application filed October 11, 1876.

To all whom it may concern:

Be it known that I, JOSEPH NAYLOR, of New York city, in the county of New York, in the State of New York, have invented an Improvement in Connecting Together the Knobs and Shanks of Door-Locks; and I do hereby declare that the following is a full and exact description thereof, reference being had to the accompanying drawings, and to the letters of reference marked thereon.

Previous to my invention the construction of the knob-shanks and the spindles of door-locks has been such that these parts had to be secured together by a screw passing through the knob-shank into the spindle of the lock.

This mode of attachment is objectionable for two reasons: first, the liability of the screw to come out, and the uncomfortableness to the hand often arising from the presence of the screw head; second, it often occurs that, from shrinkage of the door, or imperfection in putting up the fixture, the door does not quite fill the space between the knob-shanks on opposite sides, and the result is an endwise play to the lock-spindle and knobs, which is most undesirable.

I propose to overcome these evils, and provide a fixture which can, with the greatest facility, not only be fitted snugly and perfectly to the door, to start with, but can also be afterward adjusted in case of shrinkage, so as to keep the knob-shanks always snug up against the rose, and prevent all end play and rattle in the fixture, and which will also render unnecessary the use of the usual washers or rings employed to take up the end play of the spindle when the holes in the latter are so arranged that no one will permit the fastening of the knob-shanks at just the right distance apart.

To these ends and objects my invention consists in having the spindle serrated or notched on one or more sides, and providing the knob-shank with one or more toothed dogs adapted to engage with the said serrated spindle, and fasten the said spindle and knob-shank together through the medium of a rotating sleeve, all as will be hereinafter more fully described.

To enable those skilled in the art to make and use my invention, I will proceed to describe its construction and operation more

fully, referring by letters to the accompanying drawing, in which—

Figure 1 is a longitudinal section of a lock-spindle and knob embracing my invention. Fig. 2 is a cross-section of the same at the line *x x*, Fig. 1; and Fig. 3 is a view, showing in elevation the several parts detached or separated from each other.

In the several figures the same part will be found designated by the same letter of reference.

A is the spindle, which may have one of the door-knobs permanently fastened on one of its ends in any desired manner.

C is the knob, attached to the other end of the spindle, and which (as usual) has to be secured to the spindle at the time of putting the lock on the door, and at a certain point dependent upon the thickness of the door.

The spindle A, near that end on which has to be secured the knob C, is serrated or notched, file-like, on one or more of its sides, and for a greater or less distance, as shown at *d*, and in the shank *e* of knob C are arranged two (more or less) spring-dogs, *f*, the inner operative faces of which are serrated correspondingly to the notched faces of spindle A, and which are made to engage with the said spindle, for the purpose of securing it and the knob-shank *e* together in a manner to be presently explained.

G is a tubular sleeve, that fits snugly over the shank *e*, and by means of which the spring-dogs *f* are forced and held in engagement with the spindle A, as I will now explain.

This sleeve or tube G has made in it two holes, *i i*, corresponding in size and shape to the projecting outer heads of the dogs *f*, and is free to turn round, but not too easily, on the shank *e*. In its normal position it is so set on the shank *e* that the projections or heads of the spring-dogs *f* protrude into or through its holes *i i*; but when turned round on said shank (to any extent less than half-way round) it forces inward the said spring-dogs *f*, so that their inner serrated faces are made to interlock or engage with the notched portions *d* of the spindle, and thus the shanks *e* and spindle A are securely coupled or fastened together.

It will be understood that just in proportion to the fineness of the interlocking serrations

or teeth on the spindle and spring-dogs can the shank *e* be adjusted, and secured at any one of the numerous points more or less close together on the spindle *A*, and that by simply turning the sleeve *G* to a position in which the spring-dogs *f* will be permitted to disengage themselves, or withdraw from the spindle, the knob *C* may be moved upon the spindle endwise of the latter, or may be removed from the latter.

And it will be seen that by the employment of the interlocking devices in the shank *e*, in combination with the notched spindle adapted to be engaged by them, and the tubular sleeve for enforcing and breaking the engagement of the dogs and spindle at pleasure, as described, not only is the knob-shank fastened to the spindle without the employment of any screw, and without the presence of any projecting device to induce to discomfort in handling the knob, but the knob may be fastened at any desired point in putting up the fixtures,

to closely confine the door between the roses or shank-collars, and prevent all play or rattle, and can at any time (and without the use of any tools) be adjusted and refastened on the spindle.

What I claim as my invention, and desire to secure by Letters Patent, is—

In combination with the knob-shank and a notched or properly serrated spindle, the spring dog or dogs *f*, a portion of which projects through the knob-shank, and a tubular sleeve, *G*, with one or more holes, *i i*, whereby the dogs are confined to secure the knob-shank to the spindle, and its release effected, substantially as hereinbefore set forth.

In testimony whereof I have hereunto set my hand and seal this 2d day of October, 1876.

JOSEPH NAYLOR. [L. s.]

In presence of—

J. N. MACINTIRE,
JACOB FELBEL.