

J. H. SMITH.
TURBINE WATER-WHEEL.

No. 191,379.

Patented May 29, 1877.

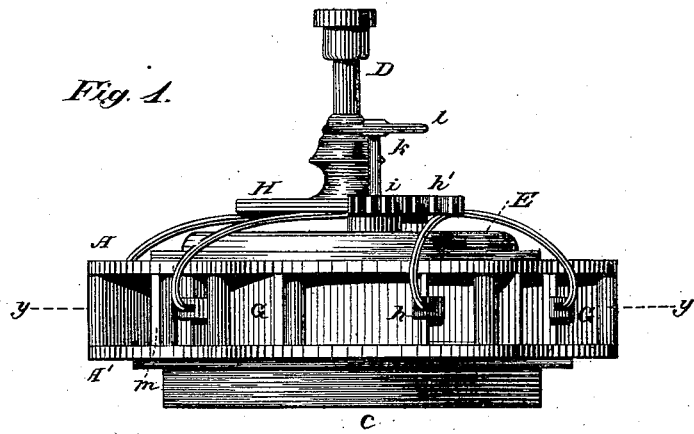
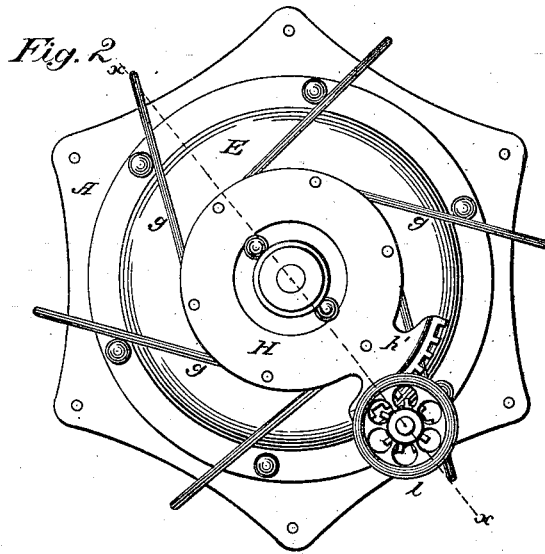

Attest:
Just R. Brooks
P. Elmer

Inventor:
Joseph H. Smith
by *Louis Bagger & Co*
Atty

J. H. SMITH.
TURBINE WATER-WHEEL.

No. 191,379.

Patented May 29, 1877.

Fig. 4

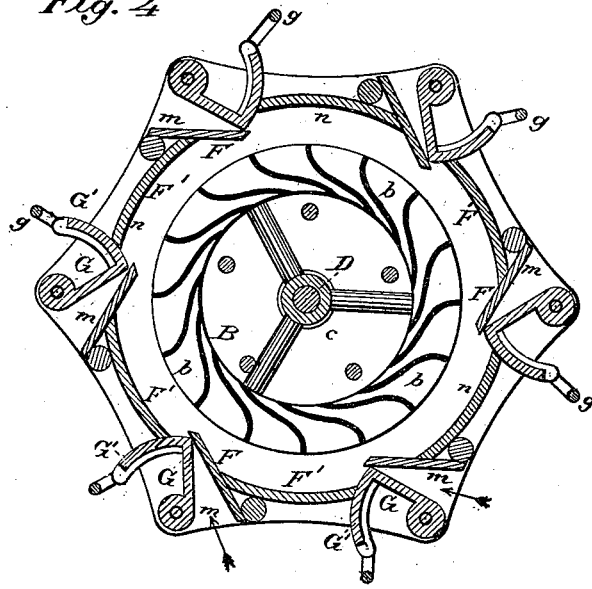
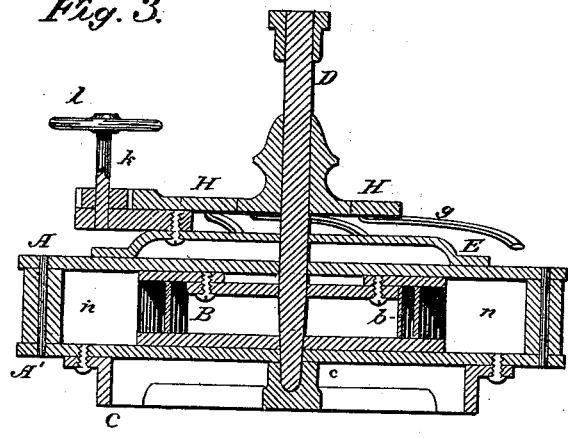

Fig. 3.



Attest.
Geo. P. Brooks
E. E. Covert

Inventor
Joseph H. Smith
 by *Louis Baggett*
Atty.

UNITED STATES PATENT OFFICE.

JOSEPH H. SMITH, OF ATHENS, TENNESSEE.

IMPROVEMENT IN TURBINE WATER-WHEELS.

Specification forming part of Letters Patent No. **191,379**, dated May 29, 1877; application filed April 21, 1877.

To all whom it may concern:

Be it known that I, JOSEPH H. SMITH, of Athens, in the county of McMinn and State of Tennessee, have invented certain new and useful Improvements in Turbine Water-Wheels; and I do hereby declare that the following is a full, clear, and exact description thereof, which will enable others skilled in the art to which it appertains to make and use the same, reference being had to the accompanying drawings, which form a part of this specification, and in which—

Figure 1 is a side elevation. Fig. 2 is a top plan. Fig. 3 is a vertical section after the line *x x* in Fig. 2, and Fig. 4 is a horizontal section after the line *y y* in Fig. 1.

Similar letters of reference indicate corresponding parts in all the figures.

My invention relates to vertical water-wheels or turbines; and it consists in an improved construction of the case, gates, and mechanism for operating these, substantially as hereinafter more fully set forth, and pointed out in the claims.

In the drawings, *A* is the top and *A'* the bottom ring of the case, within which the wheel *B* rotates. The latter is of the usual construction, having a series of circumferential vertical buckets, *b*, with flaring mouths for the reception of the water. *O* is the bottom plate or "spider," bolted onto ring *A'*, and having a bearing, *c*, in the center, in which the point or pivot of the spindle *D* revolves. *E* is the top plate or covering of the case, which is screwed or bolted onto ring *A*, and has a central perforation to admit the spindle or shaft *D* to pass through.

The water inlets or chutes *n* are formed by plates or castings *F F'*, of the configuration shown in Fig. 4, which are arranged vertically and at equal distances from each other, between the top and bottom rings *A A'*. Each of these castings consists of a curved plate or piece, *F'*, and a straight plate, *F*, as shown. *G G'* are the gates, which are hinged vertically between the plates *A* and *A'*, and each of which consists of a straight plate or piece, *G*, and a projecting curved piece, *G'*, the curvature of which corresponds to a circle having the straight arm or plate *G* for its radius, and the pivoting-point of this arm for its

center, so as to enable the piece or plate *G'* to slide easily upon and form a water-tight joint with the projecting edge of the chute-plate *F'* next to it.

g are the rods for operating the gates. These are curved so as to allow their bent ends to be pivoted in bearings *h*, projecting laterally from the gates at their middle-line element. The other ends of rods *g* are pivoted in a horizontal annular plate, *H*, which has a central opening, and rotates around the annular shoulder or central raised and perforated portion of the covering-plate *E*. This disk or ring *H* may be rotated by means of a segmental ratchet, *h'*, which engages with a pinion, *i*, operated by a vertical shaft, *k*, and turn-wheel *l*, in the usual manner.

By the construction and combination of the chute-plates *F F'* and gates *G G'* as hereinbefore described, two important advantages are gained, viz: first, whether the gates be opened much or little, they will throw the water directly into the buckets of the wheel, forming, as they do, with the chute-plates *F*, a funnel, *m*, into the curved chute *n*, through which the water is admitted to the buckets; and, second, the pressure of the water in the flume within which the turbine is placed will be equal on both sides of the gate, (inasmuch as it will at all times enter the funnel *m*, whether this be opened or closed, and thus exercise a pressure on the gate-plate *G* from the inside, corresponding to the pressure on the outside,) from which it follows that the gates may at all times, and regardless of the head of water in the flume, be opened, closed, and regulated with perfect ease. By pivoting the operating-rods to the center of the outer edge of the swinging gates, instead of at the top or bottom thereof, the gates will be worked perfectly square, and are, therefore, not liable to bend in the chutes.

Having thus described my invention, I claim and desire to secure by Letters Patent of the United States—

1. In a turbine water-wheel, the combination of the chute-plates *F F'* with the swinging gates *G G'*, so as to form funnels *m*, allowing the water to impinge upon both sides of the gate, whether this is closed or open, or partially open, and thereby at all times exert

an equal pressure on both sides thereof, substantially as and for the purpose hereinbefore set forth.

2. As an improvement in turbine water-wheels, the combination of the case A A' E, stationary chute-plates F F', vertically-swinging gates G, having segments G' sliding upon the edges of chute-plates F', so as to form water-tight joints therewith, operating-rods *g*, and rotating annular disk H, all constructed

and combined to operate substantially as and for the purpose herein shown and described.

In testimony that I claim the foregoing as my own I have hereto affixed my signature in presence of two witnesses.

JOSEPH H. SMITH.

Witnesses:

JOHN A. SMITH,
NATHANIEL C. JONES.