

E. J. JONES.

DEVICE FOR SUPPLYING STEAM AND AIR BLAST TO FURNACES.

No. 191,438.

Patented May 29, 1877.

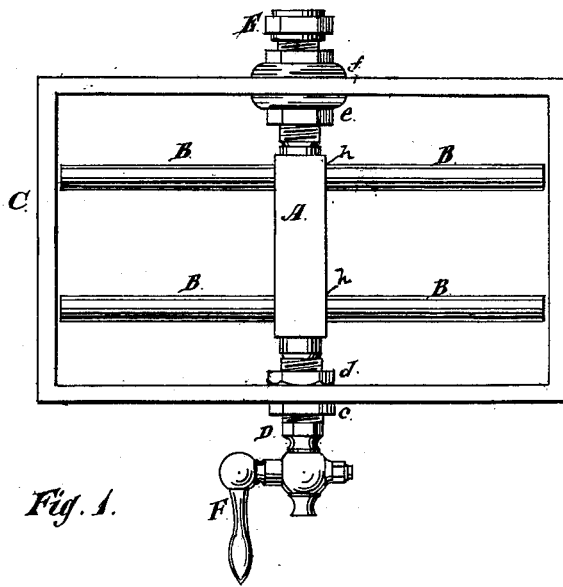

Fig. 1.

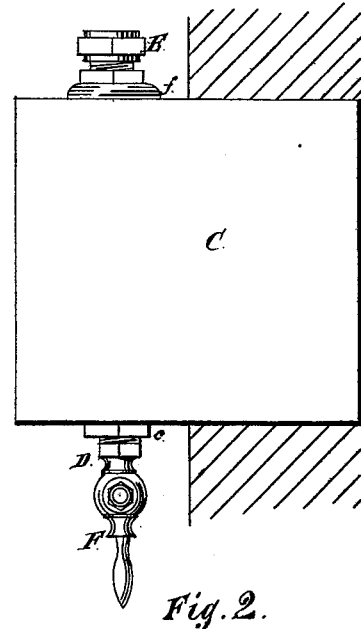

Fig. 2.

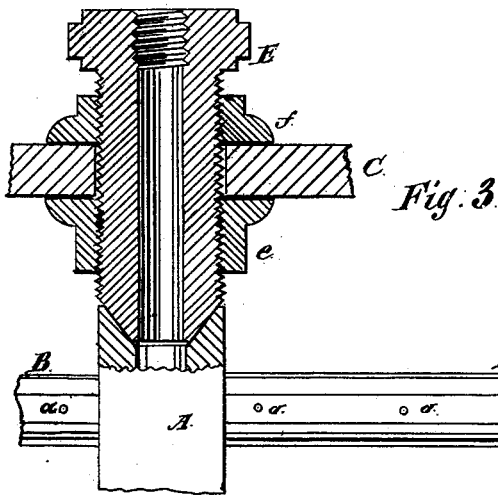

Fig. 3.

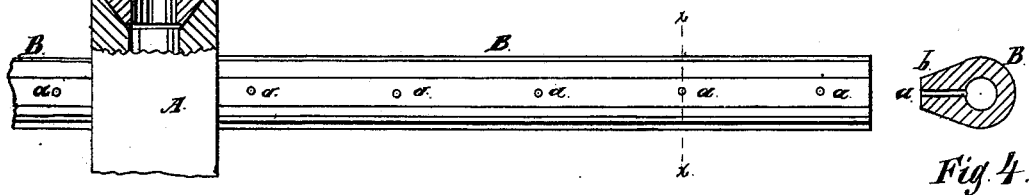

Fig. 4.

Witnesses
Wm Bond
A. T. Bruns

Inventor
Evan J. Jones.
Per Wm Bond Attorneys

UNITED STATES PATENT OFFICE.

EVAN J. JONES, OF INDIANAPOLIS, INDIANA, ASSIGNOR TO EDWARD F. CULLEN, OF SAME PLACE, AND LEONARD C. RIGGS AND DAVID ELSTNER, OF CHICAGO, ILLINOIS.

IMPROVEMENT IN DEVICES FOR SUPPLYING A STEAM AND AIR BLAST TO FURNACES.

Specification forming part of Letters Patent No. **191,438**, dated May 29, 1877; application filed May 19, 1876.

To all whom it may concern:

Be it known that I, EVAN J. JONES, of Indianapolis, Marion County, State of Indiana, have invented new and useful Improvements in Devices for Supplying a Steam and Air Blast to Furnaces, of which the following is a full description, reference being had to the accompanying drawings, in which—

Figure 1 is a front elevation; Fig. 2, a side view, showing the device in the wall of a furnace. Fig. 3 is an enlarged detail, the upper portion being shown in section, and the remainder being a rear view; Fig. 4, a section at *x* of Fig. 3.

The chief object of this invention is to provide for the introduction of a combined steam and air blast beneath the grate of a furnace; and it consists in the construction and arrangement of parts, as will be hereinafter more fully set forth, and pointed out by the claim.

In the drawings, A represents a tube. As shown, it is square, but it might be round. B are small pipes secured to A and communicating with the passage through the same. *a* are small perforations in one side of the pipes B, the outer ends of which pipes are closed. The tube A is to be connected with a steam-pipe, and A and the pipes B are to be located, preferably, in an opening or passage in the side of the furnace below the grate, such passage being open to permit the free passage of air into the ash-pit.

A convenient way of connecting the device with a furnace is shown in the drawings, C being a case open in the front and rear, in which the tube A and pipes B are located in the following manner: D is a coupling, the upper end of which is concave and adapted to receive the lower end of the tube A, which is convex, the two parts being fitted so as to form a steam-tight joint. This coupling is secured to the lower portion of the case C by means of two screw-collars, *e d*. E is another screw-coupling, the lower end of which is convex and adapted to fit the upper end of the tube A, which is correspondingly concave, and, by means of the screw-collars *e f*, E can be firmly secured to the upper portion of the case C, with its lower end tightly in contact with

the upper end of A, forming at that point a steam-tight joint. The upper end of E is adapted to be connected with, or coupled to, a steam-pipe.

I make D hollow and provide a cock, F, at its lower end for the purpose of drawing off any condensation.

I prefer to place the pipes B a little sloping, so that any condensation will blow from them into A.

The pipes B, as shown, are formed as represented in Fig. 4, being flattened upon one side, so that the outlets *a* pass through metal half an inch or more in thickness, (see *b*, Fig. 4,) rendering the blast more efficient than if the steam escaped from the side of a tube with a comparatively thin wall. The flattening of these tubes, as represented, facilitates the mingling of the air with the steam.

In use, the case C, with the devices thereto attached as shown, is to be secured in the wall of the furnace, at a point below the fire-grate in such a manner that there will be free communication from the outside through the case C into the ash-pit. A steam-pipe from the boiler is to be connected with A, and is to be provided with a suitable stop-cock. When steam is let on, it will pass into the tube A, thence into the pipes B, and be forced out, in numerous small jets, through the perforations *a* into the ash-pit and beneath the fire-grate. At the same time a strong current of air will be carried along with the steam, and the mingled air and steam produces very perfect combustion, to a great extent suppressing the smoke and adding materially to the heating capacity of a given quantity of fuel.

The case C is not a necessity, as it is evident that the tube A, connected with its pipes B, might be attached to a steam-pipe and secured in a passage located in the side of the ash-pit in some other manner; but it will be found convenient to construct and apply the devices as shown and described.

I do not limit myself to the number of tubes, B, represented, neither to the exact construction described. These tubes might be circular or curved in form, but no advantage would thereby be gained.

The tube A, also, might be enlarged into a chamber and provided with a number of small perforations; but I prefer the form shown.

I have used tubes having a long continuous slot in place of the perforations *a*, but this construction is not as desirable.

Instead of flattening the pipes B, they might be provided with nipples.

The device may be located in front as well as upon the side of the furnace. It can also be applied in places where no grate is used, in which case it must be located in the passage through which air is conducted to the fire.

I am aware that steam has been applied both above and beneath fire-grates. I am also aware that an air-blast has been used, produced by a fan or other mechanical means.

I do not claim, broadly, the introduction of steam or air to the fire, the gist of my invention being in producing an air-blast in connection with steam-jets, the action of the steam alone inducing the air current.

What I claim as new, and desire to secure by Letters Patent, is as follows:

In an apparatus for a steam and air blast for furnaces, the combination of the main supply-pipe A, perforated branch pipes B, and conical bearings and their couplings working in case C, and located under the grate-bar, substantially as described.

EVAN J. JONES.

Witnesses:

E. A. WEST,

O. W. BOND.