

L. PICKERING.
COPYING-TELEGRAPH

No. 191,464.

Patented May 29, 1877.

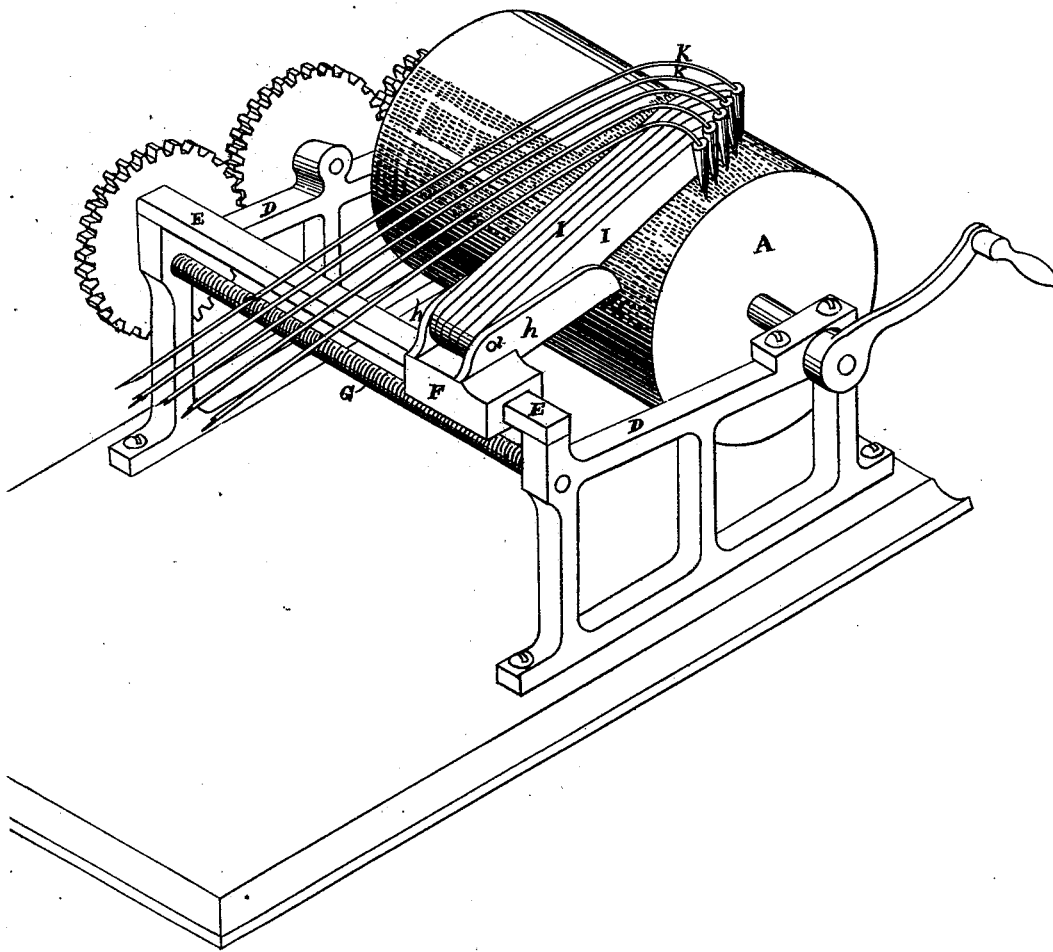

Witnesses
Geo. H. Strong
J. M. L. Boone

Inventor
Loring Pickering
By *Dewey & Co.*
His Attys

UNITED STATES PATENT OFFICE.

LORING PICKERING, OF SAN FRANCISCO, CALIFORNIA.

IMPROVEMENT IN COPYING-TELEGRAPHS.

Specification forming part of Letters Patent No. **191,464**, dated May 29, 1877; application filed April 24, 1877.

To all whom it may concern:

Be it known that I, LORING PICKERING, of the city and county of San Francisco, and State of California, have invented a Typographical Transmitter for Automatic Telegraphs; and I do hereby declare the following to be a full, clear, and exact description thereof, reference being had to the accompanying drawings.

My invention relates to a novel method of converting type-forms and other raised or engraved characters into transmitting-plates, so that, by causing the contact point or points of one or more telegraphic wires to traverse their surfaces in parallel and approximate lines, I can automatically transmit the matter represented by said forms or plates to distant stations, where the letters or characters can be reproduced by a suitable recording-instrument.

The principal object of my invention is to enable me to convert newspaper and other like forms of printing-types or engravings into telegraphic transmitters in a cheap, simple, and convenient manner, so that a fac-simile copy of the newspaper or other matter can be automatically transmitted over telegraphic wires in a speedy and convenient manner.

As the faces of the types used in newspaper-printing are usually quite small when compared with the types heretofore used in automatic telegraphy, a peculiar arrangement or adjustment of the contact-points is necessary, where several wires are used, in order to permit the several points to trace, in lines sufficiently close together to reproduce the outline of each letter.

My method of arranging these points in order to accomplish the object mentioned, together with the manner of preparing and operating my improved typographical transmitter, is more fully set forth and described in detail in the following specification, in which reference is made to the accompanying drawings, in which—

Figure 1 is a perspective view of my device.

Preliminarily, I will state that my invention can be applied to either flat or curved type-forms. In either case, the method of preparing the plate is the same.

For the purpose of this specification I have, in the present instance, represented a curved

form applied to a cylinder, A, as hereinafter described.

To prepare my transmitting-plate, I take a printer's form, such as is set up in ordinary printing-type for printing upon a printing-press, and prepare from it a stereotype fac-simile in the ordinary manner of preparing stereotype-plates. I then fill the space in the plate between the types with some non-conducting material or substance, so as to insulate the faces of the types from each other and render the surface smooth and even. If the type-form is curved, such as is used on a cylinder-press, I secure it upon the cylinder A before applying the filling of non-conducting substance, and then, by rendering the surface of the material smooth and level with the faces of the types, so as to expose the faces, the cylinder is ready to be mounted in the frame D.

A filling of shellac or any other non-conducting substance of the consistency of putty, such as can be applied readily either warm or cold, will answer, and it is well, after the filling has been completed and the surface leveled, to sandpaper or otherwise polish or clean the surfaces of the type, to free them from any adhering portion of the substance. The type-plate can then be put in circuit by connecting one of the battery-wires with it, or it may be preferable to construct the cylinder A of copper, and allow its shaft to bear in the metallic frame D. Then, by insulating the frame the wire can be connected with it, so that the copper cylinder and the type-plate will be brought into the circuit.

It will be evident that I will now have a metallic type-plate in which the surfaces of the type are exposed in regular order, just as the types were originally set up, and with which it is only necessary to make the proper connections, to transmit a fac-simile copy to the opposite end of the contact wire or wires.

E is a horizontal bar, which extends across the frame D parallel with the cylinder A, and at a short distance from it. A slide, F, is arranged to be moved along this bar by means of a screw, G, which extends across the frame just below the bar E. The upper side of the slide is formed with two lugs or sides, *h h*, at a short distance apart, between which I place one end of each of several parallel arms, *I I I*,

and secure them by a shaft, *i*, which passes through the lugs or sides *h h*, and also through the ends of the arms. The opposite or free ends of these arms will then rest upon the cylinder *A*, one a little in advance of the other, as hereinafter described. The free end of each of these arms will then adjust itself to any inequalities on the face of the cylinder, independent of all the other arms.

The shortest arm on one side of the series may be straight, or preferably provided with a very slight curve at its outer end. The outer end of the next arm is slightly curved, so as to carry its extremity nearly in front of the first arm. The third arm is curved a little more, so as to bring its extremity nearly in front of the second, and so on, for as many arms as are used. This will cause the extremities of the several arms to stand in an oblique or spiral direction with reference to the surface of the cylinder.

K K K are the circuit-wires, as many being used as there are arms *I*. Each of these wires is provided with a platinum point, and the end of each wire is passed through a proper hole in the end of one of the arms, so that its point will project below the arm, and in this position the wires are secured and insulated from the arms by any suitable non-conducting filling placed around them in the holes.

Now, as the cylinder is rotated, the contact-points of the wires *K K K* will move over the surface of the cylinder and be fed slowly by the screws *G* from end to end of the cylinder, so as to come in contact with every part of the type-faces. The electric circuit will be completed in each wire every time its contact-point touches the metallic face of one of the types, and the circuit will be broken when the point touches the intermediate filling of non-conducting material.

A single wire or any number of wires can be used. I prefer, however, to use a number of wires, and a corresponding number of contact-points, so as to accomplish the transmission more speedily.

For receiving the telegram, I mount a drum at the opposite end of the lines, which will

carry the chemically-prepared paper upon which the letter of the typographical transmitter is to be recorded by chemical decomposition in the ordinary manner of recording characters by the automatic telegraph system, or an arrangement could be applied for recording with ink or pencil. The recording-cylinder *I* will make larger in diameter than the transmitting-cylinder, and provide the two cylinders with a synchronal movement, so that the characters or letters will be enlarged at the receiving end of the line.

I thus provide for transmitting, in a simple and convenient manner, typographical engraved or other raised matter, so that a facsimile copy of the matter represented by the types can be speedily reproduced at a distant station.

Having thus described my invention, what I claim, and desire to secure by Letters Patent, is—

1. The method of converting forms of printing-types into transmitting-plates for telegraphic purposes, consisting in filling between the faces of the types, either in the original form or in a stereotype cast taken therefrom, a non-conducting substance that will, at the same time, insulate the faces of the types and provide a smooth level surface for the contact-points of the wires to pass over, substantially as and for the purpose described.

2. The hinged arms *I I I*, arranged to carry the points of the wires *K K K* in their free ends, in combination with the slide *F* and feed-screw *G*, substantially as and for the purpose described.

3. The arrangement of the contact-points of the several parallel wires of an automatic telegraph apparatus in an oblique or spiral manner, substantially as and for the purpose described.

In witness whereof I have hereunto set my hand and seal.

LORING PICKERING. [L. S.]

Witnesses:

JNO. L. BOONE,
FRANK A. BROOKS.