

H. L. BORDEN.
GAGE-COCK.

No. 192,145.

Patented June 19, 1877.

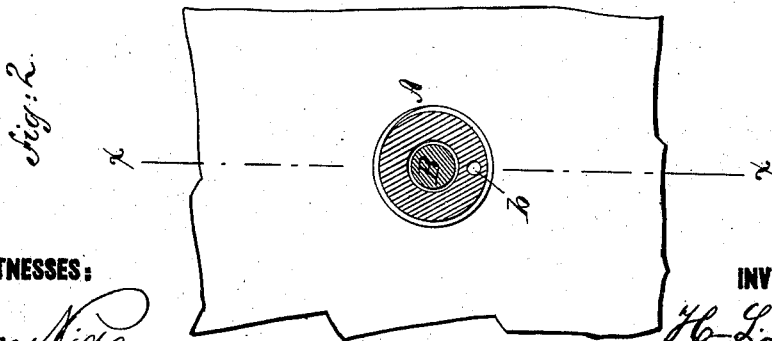
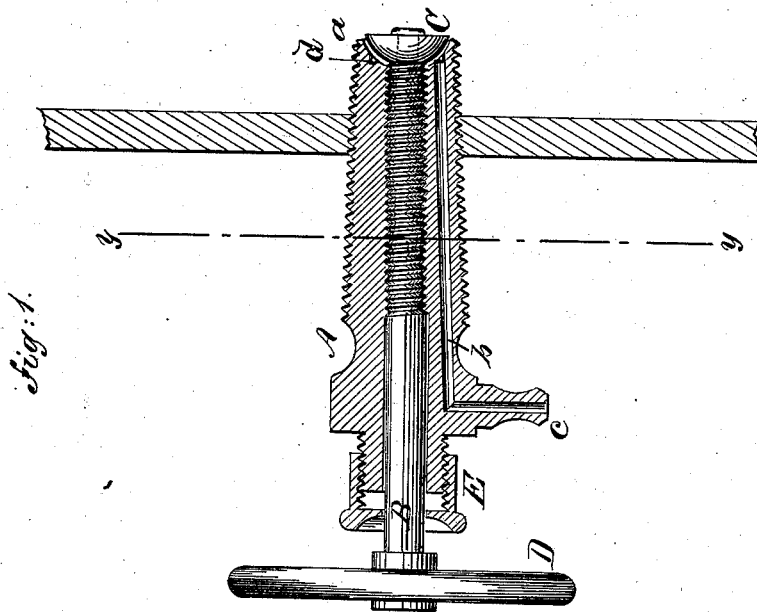

WITNESSES:

Chas. Nida
J. H. Scarborough

INVENTOR:

H. L. Borden

BY

Munn & Co.
ATTORNEYS.

UNITED STATES PATENT OFFICE.

HENRY LEE BORDEN, OF ELGIN, ILLINOIS.

IMPROVEMENT IN GAGE-COCKS.

Specification forming part of Letters Patent No. 192,145, dated June 19, 1877; application filed February 3, 1877.

To all whom it may concern:

Be it known that I, HENRY LEE BORDEN, of Elgin, in the county of Kane and State of Illinois, have invented a new and Improved Gage-Cock, of which the following is a specification:

Figure 1 is a side elevation in section on line *x x* in Fig. 2. Fig. 2 is a transverse section on line *y y* in Fig. 1.

Similar letters of reference indicate corresponding parts.

My invention consists of a gage-cock for steam-boilers, the valve of which is within the boiler, and is opened and closed by a threaded spindle that fits an internal thread in the body of the gage-cock. The internal thread and the thread of the spindle extend from the valve outward beyond the exterior of the boiler. A passage is provided in the body of the gage-cock for the escape of steam or water, which is closed by the valve.

The object of the invention is to provide a gage-cock that will not allow of the escape of hot water or steam if it should be broken off outside of the boiler-shell.

In the drawing, A is the body of the gage-cock, which is bored longitudinally through its center, and threaded internally to receive the spindle B, upon which a thread is cut that fits the internal threads of the body A. The inner end *a* of the body is concaved to receive the convex valve C, which is attached to the end of the threaded portion of the spindle B. The outer end of the spindle B is provided with a hand-wheel, D, and is surrounded by a stuffing-box, E, at the outer end of the body A.

A passage, *b*, runs lengthwise through the body A, the inner end of which terminates at the annular groove *d* cut in the valve-seat, and is closed by the valve C, and its outer end terminates in a nozzle, *c*. The body A is threaded externally and screwed into the boiler in the usual way.

The internal thread of the body A and the thread of the spindle B extend from the valve and valve-seat outward beyond the boiler-shell, so that if the gage-cock should by accident become broken outside of the boiler-shell the valve would be undisturbed, and the accidents that usually follow the breaking of a gage-cock entirely avoided.

The valve of the cock is opened or closed by turning the screw by means of the hand-wheel.

The stuffing-box at the outer end of the body A is not deemed essential, as little, if any, water or steam can escape around the spindle.

Having thus described my invention, I claim as new and desire to secure by Letters Patent—

A gage-cock for steam-boilers consisting of a body, A, bored longitudinally and threaded internally, and provided with the passage *b* and valve-seat, as described, a threaded spindle, B, that extends through the body, and a valve, C, attached to the inner end of the said spindle, substantially as herein set forth.

HENRY LEE BORDEN.

Witnesses:

NORMAN J. BLOOMFIELD,
VINCENT S. LOVELL.