

D. B. REYNOLDS.

MACHINERY FOR FORMING BOX-TOES FOR BOOTS AND SHOES.  
No. 192,190.

Patented June 19, 1877.

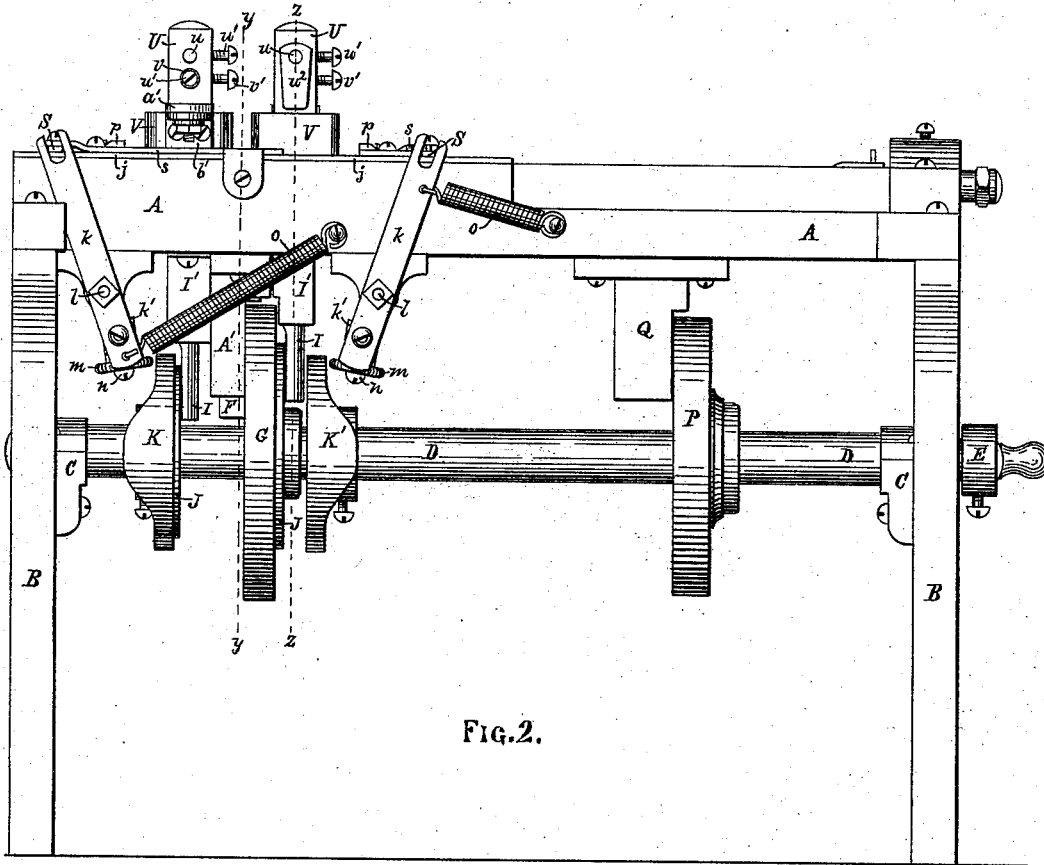

FIG. 2.

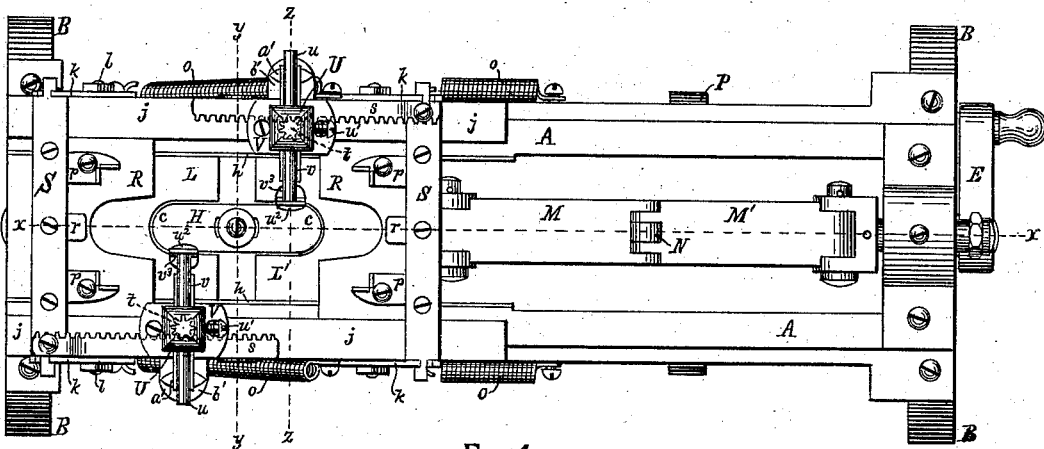

FIG. 1.

WITNESSES:

*N. C. Lombard,*  
*& A. Hemmenway*

INVENTOR:

*Davis B. Reynolds.*

D. B. REYNOLDS.

MACHINERY FOR FORMING BOX-TOES FOR BOOTS AND SHOES.

No. 192,190.

Patented June 19, 1877.

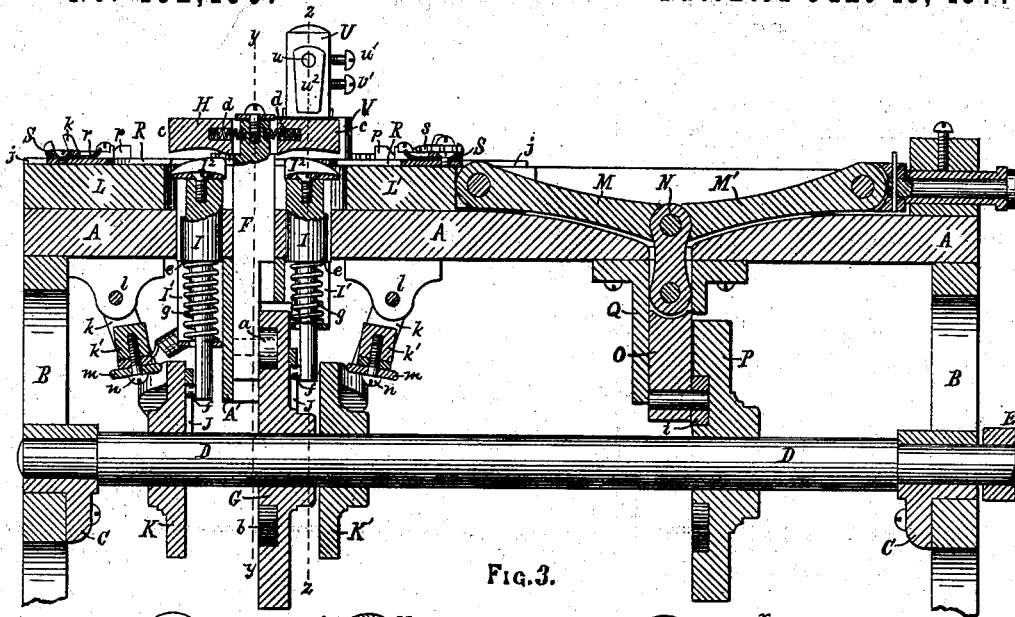

FIG. 3.

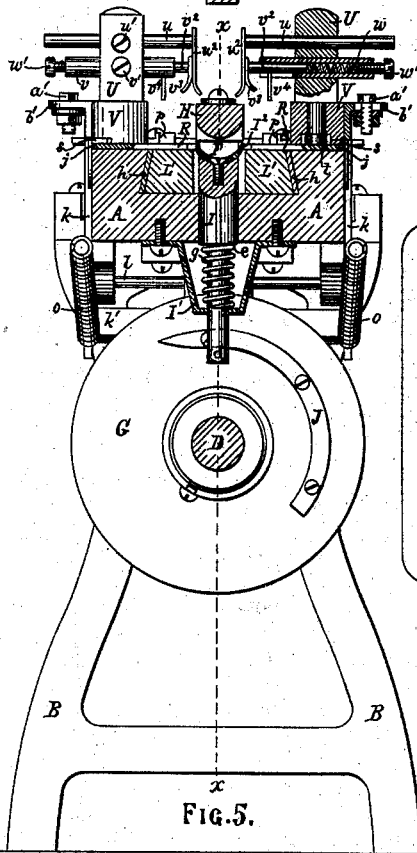

FIG. 5.

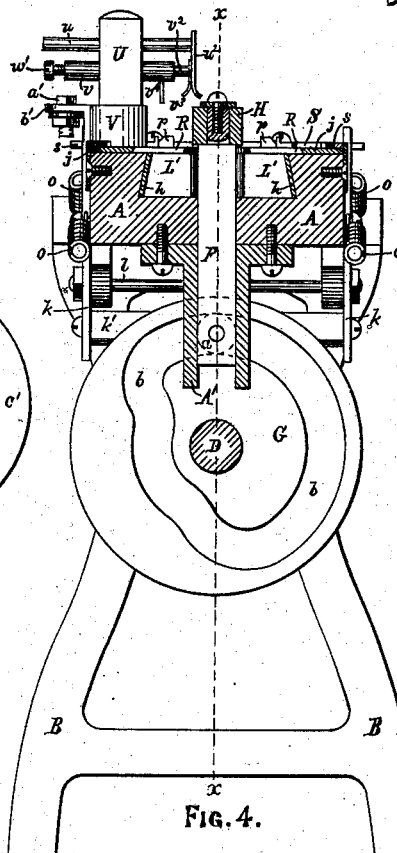

FIG. 4.

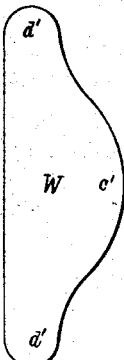

FIG. 6.

WITNESSES:  
*N. G. Lombard*  
*E. A. Hemmenway*

INVENTOR:  
*Davis B. Reynolds*

# UNITED STATES PATENT OFFICE.

DAVIS B. REYNOLDS, OF BROCKTON, MASSACHUSETTS, ASSIGNOR OF ONE-HALF HIS RIGHT TO WALTER L. FRENCH, OF SAME PLACE.

## IMPROVEMENT IN MACHINERY FOR FORMING BOX-TOES FOR BOOTS AND SHOES.

Specification forming-part of Letters Patent No. **192,190**, dated June 19, 1877; application filed May 12, 1877.

*To all whom it may concern :*

Be it known that I, DAVIS B. REYNOLDS, of Brockton, in the county of Plymouth and State of Massachusetts, have invented certain new and useful Improvements in Machines for Forming Box-Toes for Boots and Shoes, of which the following, taken in connection with the accompanying drawings, is a specification :

My invention relates to a machine for molding a box-toe from a flat piece of material after being cut to the proper shape; and it consists, first, in the combination of a double male die adapted to be moved vertically and horizontally, two vertically-reciprocating followers or jaws, each adapted to seize a blank and hold it in contact with one of the male dies, a fixed female die, and a reciprocating female die, all arranged and adapted to form two box-toes at the same time.

My invention further consists in the use, in combination with a vertical rod or bar, mounted in fixed bearings and adapted to be moved only in a vertical direction, of a double male die, so mounted upon said rod that it may be moved vertically with said rod, and at the same time it may be moved horizontally thereon, as will be more fully described.

My invention further consists in the combination, with a vertically-reciprocating rod or bar, of a double male die, mounted thereon so as to be movable horizontally thereon, and one or more springs set in said male die-block, or between it and the rod or bar on which it is mounted, and adapted to move said male die horizontally in one direction after it has been moved in the opposite direction in the act of molding a box-toe, as will be described.

My invention further consists in the use, in combination, of a vertically-reciprocating male die, a horizontally-reciprocating female die adapted to engage with said male die, a toggle-joint connected to said female die, a vertically-reciprocating rod or bar connected to the knuckle of said toggle, and a cam adapted to act upon said vertical rod, and impart through it and the toggle a reciprocating motion in a horizontal direction to the female die.

My invention further consists in the use, in combination, of a rod or bar mounted in fixed

bearings in a vertical position, a cam adapted by its revolution to impart to said rod a vertical reciprocating motion, and a double male die, secured to the upper end of said rod in such a manner that it may be moved horizontally thereon.

My invention further consists in the use, in combination with a male die adapted to be moved vertically and horizontally, of a follower or clamping-jaw, fitted to and adapted to be moved vertically in fixed bearings, a spring adapted to force said follower upward, and a cam adapted to act thereon intermittently to draw said follower away from said male die, to permit the feeding of the blank to the die, as will be hereafter described.

My invention further consists in the combination, with a vertically-reciprocating male die and a vertically-yielding follower or clamping-jaw, of a horizontally-reciprocating feed-plate, adapted to receive the blank and automatically feed it between the male die and its follower.

My invention further consists in the combination of a vertically-reciprocating male die or former, a vertically-yielding follower, a feed-plate mounted in horizontal slides, one or more levers, and a cam adapted to impart to said feed-plate an intermittent-reciprocating motion.

My invention further consists in the combination, with the feed-plate, of one or more registering-gages, adapted to aid the operator in the proper location of the blank on the feed-plate, and to insure the movement of the blank with the feed-plate as it moves toward the male die.

My invention further consists in the use, in combination with the feed-plate, of a spring secured thereon, and adapted to seize the blank by the center of its rear side when placed in position on the feed-plate, and hold it firmly until it is clamped between the male die and its follower.

My invention further consists in the use of a pair of gripping-jaws mounted upon a vertical axis, and adapted to seize the molded box as it is moved upward after being formed by the dies, remove it from between the male die

and its follower, rotate partially about its axis, and then release the box, as will be described.

My invention further consists in the use, in combination with the reciprocating feed-plate, of a toothed rack adapted to be reciprocated in unison with said feed-plate, and to engage with a toothed pinion formed upon or secured to axial spindle of the discharge clamping-jaws, and by its reciprocation impart to said jaws a semi-rotation about said axis.

My invention further consists in the use, in combination with the discharge clamping-jaws, of an adjustable cam-block for opening said jaws to release the finished box-toe.

Figure 1 of the drawings is a plan of a machine embodying my invention. Fig. 2 is a side elevation. Fig. 3 is a longitudinal vertical section on line *xx* on Figs. 1, 4, and 5. Fig. 4 is a vertical transverse section on line *yy* on Figs. 1, 2, and 3. Fig. 5 is a vertical transverse section on line *zz* on Figs. 1, 2, and 3; and Fig. 6 is a plan of a blank from which a box-toe is to be formed.

A is the bed or table of the machine, supported upon the legs B B, upon which is mounted, in suitable bearings C C, the shaft D, to which a continuous rotary motion may be imparted by the crank E, or a pulley and belt. (Not shown in the drawings.)

A' is a stand secured to and projecting downward from the under side of the table A, and forming a bearing for the vertical rod or bar F, provided at its lower end with the truck *a*, fitting into and acted upon by the path *b* of the cam G, in such a manner that the revolution of the shaft D and cam G secured thereto shall impart to said bar F an intermittent reciprocation in a vertical direction.

H is an oblong block of metal, having formed upon each end thereof a male die, *c*, and secured to the upper end of the bar F in such a manner that it is compelled to move in a vertical direction with the bar F, while, at the same time, it may be moved horizontally thereon, it being returned to and retained in its normal or central position by the springs *d d* when the power which moves it from such position is removed.

I I are two vertical rods fitted to bearings in the table A and the stands I', and each having formed upon or secured to its upper end the curved follower-plate I<sup>2</sup>, made to fit and partially embrace the die *c*, and also provided with the shoulder *e* and truck *f*, as shown in Fig. 3.

A spring, *g*, surrounds the rod I between the stand I' and the shoulder *e*, the tension of which tends to force the rod I upward and cause the follower-plate I<sup>2</sup> to engage with the die *c*, to seize and hold the blank of leather-board or other material when placed between it and the die *c*.

J J are cam-shaped segmental lips formed upon or secured to the back sides of the cams G and K, and each adapted to engage with the truck *f* on one of the rods I to draw it

downward against the tension of the spring *g*, and hold it till the blank is fed between it and the die *c*.

L is a female die secured in a fixed position to the upper side of the table A, at one end thereof, and contiguous to one of the male dies *c*, with which it co-operates to form or shape a box-toe.

L' is a similar female die arranged contiguous to the opposite male die *c*, and fitted to the horizontal slides *h h* in such a manner that it may be reciprocated horizontally to and from said male die *c* to compress and set to shape the box-toe.

This horizontal reciprocation of the female die L' is produced by means of the toggle-links M and M', connecting-rod N, vertically-reciprocating rod O, and cam P, the rod O being provided with the truck *i*, and having its bearing in the stand Q secured to and projecting downward from the under side of the table, as shown in Fig. 3.

R R are two feed-plates, placed one above each of the female dies L and L', and in close contact with their upper surfaces, said plates each being attached to a bar, S, extending transversely across the table A, above the slides *h h* and the parallel plates *j j*, between which said feed-plates are guided in their reciprocation to and from the male dies *c c*.

A lever-frame, consisting of the two levers *k k*, one upon either side of the table A, and the connecting-bar *k'*, is pivoted at *l* to the under side of the table A, the upper ends of the levers *k k* being forked or slotted to engage with the ends of the bar S, as shown in Figs. 1 and 2.

An oscillating motion is imparted to the levers *k k*, and consequently a reciprocating motion to the feed-plate R, by means of the side-throw cam K or K' acting upon the truck *m*, mounted upon the stud *n* set in the bar *k'*, to move the parts in one direction, and the springs *o o* to move them in the opposite direction.

To the upper side of each of the feed-plates R R are secured two gages, *p p*, to register the blank when placed thereon to be fed to the die, and a spring, *r*, secured to the center of the width of said feed-plate, with its forward end a little in the rear of the front or working end of the gages *p p*, as shown in Fig. 1.

To each of the bars S is attached, so as to reciprocate therewith, a toothed rack, *s*, which engages with the pinion *t* secured to the lever end of the vertical spindle U, which has its bearing in the block V, secured to the upper side of the slide *h* directly opposite to one of the male dies *c*, as shown in Fig. 1.

The spindle U extends, in an enlarged form, some distance above the block V, and has set therein, at right angles to its axis, the rod *u* and tube *v*, so as to be adjustable therein, and held in the desired position, respectively, by the set-screws *u'* and *v'*.

The inner end of the rod *u* has secured thereto or formed thereon the downwardly-

projecting curved plate  $u^2$ , and in the inner end of the tube  $v$  is fitted the rod  $v^2$ , having secured to or formed upon its end next to the plate  $u^2$  a correspondingly-shaped plate,  $v^3$ , the opposite end of the rod  $v^2$  resting against the spring  $w$  inclosed in the tube  $v$ , as shown in Fig. 5.

The outer end of the tube  $v$  is provided with the screw  $w'$ , by means of which the tension of the spring  $w$  may be regulated.

The rod  $v^2$  has set therein a pin,  $v^4$ , which projects downward therefrom through a slot in the tube  $v$ , and serves the purpose of preventing the rod  $v^2$  from being rotated in the tube  $v$ , and also as a means, in combination with the cam-block  $a'$ , of separating the jaw-plates  $u^2$  and  $v^3$  for the purpose of releasing the molded box-toe when the spindle  $U$  is rotated a half-revolution about its axis.

The cam-block  $a'$  is adjustably secured upon the bracket  $b'$ , as shown in Fig. 5.

Figs. 1 and 2 of the drawings are made with the parts in the position when the male die has just reached its lowest position, and before the movable female die has commenced to move forward to compress and set the shape of the box-toe held in the dies.

Figs. 3, 4, and 5 represent the male die in its extreme upward portion, the followers drawn down, and the feed-plates just ready to move forward to convey blanks between the male dies and their followers.

A blank,  $W$ , (shown in Fig. 6,) being placed on each of the feed-plates  $R R$ , with the point  $c'$  inserted under the spring  $r$  and the points  $d' d'$  bearing against the gages  $p p$ , if the shaft  $D$  is set in motion the blanks  $W$  will be carried between the male dies  $c c$  and the follower-plates  $P^2$ , in which position they are held till seized between the male dies  $c c$  and the followers  $P^2$ , when the feed-plates recede and, the male die-block continuing to descend, the end and rear side of the blanks are turned up around the male dies by being drawn down into the female dies  $L$  and  $L'$ .

When the male die-block has reached the extreme of its downward motion the female die  $L'$  is moved horizontally toward the die-block  $H$ , compressing the partially-formed box-toe held between it and the female die  $L'$ , and moving the die-block  $H$  horizontally upon the vertical rod  $F$ , forcing it into the fixed female die  $L$ , and compressing a second box-toe held between the block  $H$  and the female die  $L$ .

The female die  $L'$  then recedes, removing the pressure from the die-block  $H$ , and the spring  $d$ , reacting thereon, returns the block  $H$  to its normal or central position on the bar or rod  $F$ , when the block  $H$  is moved upward, being followed by the followers  $P^2$ , and removing the molded box-toe from the female dies  $L$  and  $L'$ , and forcing one of the turned-up ends of each of said box-toes between one pair of the plates  $u^2$  and  $v^3$ , and the followers  $P^2$  are then drawn down away from the dies  $c c$ . The feed-plates  $R R$  commence to move toward the male dies again, the jaws  $u^2 v^3$  are

moved about the axis of the spindles  $U$ , carrying with them the molded box-toe till the pins  $v^4$  come in contact with the inner side of the cam-blocks  $a'$ , when the jaw  $v^3$  is forced away from the jaw  $u^2$ , releasing the molded box-toes and allowing them to fall.

What I claim as new, and desire to secure by Letters Patent of the United States, is—

1. The combination of the block  $H$ , having formed upon opposite ends thereof two male dies,  $c c$ , and adapted to be moved vertically and horizontally, two vertically-yielding followers,  $P^2 P^2$ , the fixed female die  $L$ , and horizontally-reciprocating female die  $L'$ , all arranged and adapted to operate substantially as and for the purposes described.

2. The combination of the rod  $F$ , mounted in fixed bearings and adapted to be moved only in a vertical direction, and the block  $H$ , having formed on either end thereof a male die,  $c$ , and secured to the upper end of said rod  $F$ , and adapted to move vertically therewith and horizontally thereon, substantially as described.

3. The combination of the rod  $F$ , die-block  $H$ , and one or more springs,  $d$ , all arranged and adapted to operate substantially as and for the purposes described.

4. The combination of a vertically-reciprocating male die, a horizontally-reciprocating female die, adapted to engage with said male die, a toggle-joint connected to said female die and some fixed portion of the machine, and adapted to impart to said female die a reciprocating motion, and a cam connected by suitable rods or levers to the knuckle of said toggle, and adapted to impart motion thereto, substantially as and for the purposes described.

5. The combination of the rod  $F$ , provided with the truck  $a$ , the cam  $G$ , adapted to impart to the rod  $F$  a vertical reciprocating motion, and the die-block  $H$ , secured to the rod  $F$ , and adapted to be moved vertically therewith and horizontally thereon, substantially as described.

6. The combination of a male die adapted to be moved vertically and horizontally, a follower or clamping-jaw fitted to and adapted to be moved vertically in fixed bearings, a spring adapted to force said follower upward, and an intermittently-acting cam adapted to draw said follower away from said male die, substantially as and for the purposes described.

7. In combination with a vertically-reciprocating male die, a vertically-moving follower or clamping-jaw, and a fixed or horizontally-reciprocating female die, a reciprocating feed-plate adapted to receive the blank and automatically feed it between the male die and its follower, substantially as described.

8. In combination with the die-block  $H$  and follower  $P^2$ , the feed-plate  $R$ , lever-frame  $k k$ , truck  $m$ , and the cam  $K$  or  $K'$ , all arranged and adapted to operate substantially as and for the purpose described.

9. In combination with the horizontally-re-

reciprocating feed-plate R, one or more registering-gages,  $p$ , secured thereon, all arranged and adapted to operate substantially as and for the purpose described.

10. In combination with the feed-plate R, the spring  $r$ , arranged and adapted to operate substantially as and for the purpose described.

11. In combination with a vertically-reciprocating male die and a fixed or movable female die adapted to mold a box-toe, a pair of gripping-jaws, adapted to receive and gripe the box-toe as it is moved upward out of the female die, withdraw it from the male die, and discharge it at one side of the machine, substantially as described.

12. The combination, with the feed-plate R,

of a toothed rack,  $s$ , pinion  $t$ , vertical spindle U, and jaw-plates  $w^2$  and  $w^3$ , all arranged and adapted to operate substantially as and for the purpose described.

13. The combination of the vertical spindle U, fixed jaws  $w^2$ , tube  $v$ , rod  $v^2$ , jaw-plate  $w^3$ , pin  $v^4$ , spring  $w$ , and adjustable cam-block  $a'$ , all arranged and adapted to operate substantially as and for the purposes described.

Executed at Boston, Massachusetts, this 9th day of May, A. D. 1877.

DAVIS B. REYNOLDS.

Witnesses:

N. C. LOMBARD,

E. A. HEMMENWAY.