

A. J. REDWAY.

RESERVOIRS FOR STOVES AND RANGES.

No. 192,280.

Patented June 19, 1877.

Fig. 1

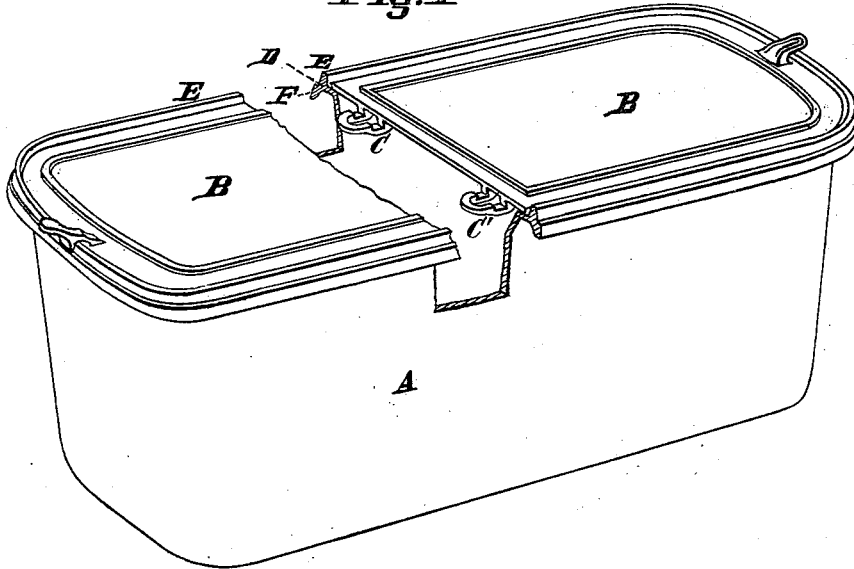
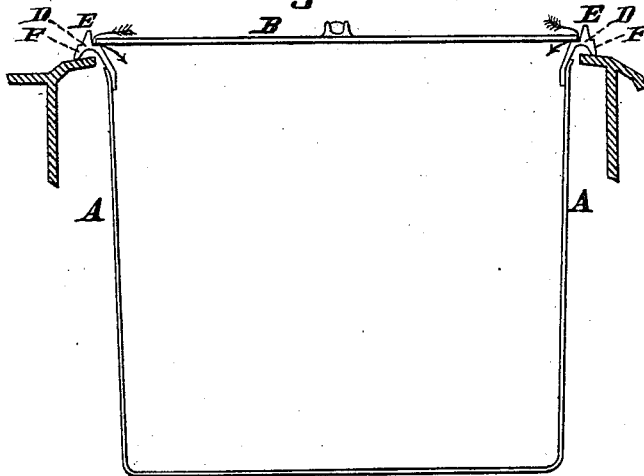

Fig. 2



Attest

*John C. Jones*  
*Edgar J. Cross*

Inventor

*Albert J. Redway*  
By *V. Millward*  
Attorney

# UNITED STATES PATENT OFFICE.

ALBERT J. REDWAY, OF CINCINNATI, OHIO, ASSIGNOR TO REDWAY & BURTON, OF SAME PLACE.

## IMPROVEMENT IN RESERVOIRS FOR STOVES AND RANGES.

Specification forming part of Letters Patent No. 192,280, dated June 19, 1877; application filed May 5, 1877.

*To all whom it may concern:*

Be it known that I, ALBERT J. REDWAY, of Cincinnati, Hamilton county, State of Ohio, have invented an Improvement in Reservoirs for Cook Stoves and Ranges, of which the following is a specification:

My invention consists in providing an elevated ridge around the exterior covers or lids of the reservoir, for the purpose of collecting and returning the condensed steam or vapor from said covers or lids to the reservoir, so that water-drippings resulting from the condensation of steam upon the cover or lids are not permitted to trickle upon the stove, and are returned into the reservoir itself, combined with a pendent ridge around the under side of the rim of the reservoir to prevent the running of water into the hot closet of the stove when the reservoir is being filled.

In the accompanying drawings, Figure 1 is a perspective view, partly sectioned, embodying my invention. Fig. 2 is a cross-section of the same.

A is the reservoir and B the cover or lids of the same. The reservoir may be formed with a stiff metallic ring cast in one piece with it, as shown in Fig. 1, or the cast rim may be secured to a sheet-metal reservoir, as shown in Fig. 2. C C' represent the female part of the fastenings, which connect the parts of the cover B together, the portion of the cover which contains the male parts of the fastenings being removed in the section. D represents the rim around the edge of the reservoir, commonly used to stiffen the same. It is made usually in such a way that the cover or lids B projects above its upper portion, and consequently any water resulting from the condensation of steam upon the cover will run and drip over onto the stove. To obviate this difficulty I provide the rim D with an elevated ridge of metal, E, entirely around the reservoir, as shown in the two figures, and so

elevated that its upper edge is in a plane above the plane of the upper surface of the cover.

In the operation of boiling water in this reservoir, therefore, so provided with the elevated ridge E, all water which may be collected by the condensation of steam upon the cover or lids B will be collected inside of the edge of the elevated rim E, and by reason of the customary absence of close fits between the cover and the reservoir in this class of manufactures, will fall back into the reservoir. By the use, therefore, of this elevated rim, one of the most annoying occurrences in the operation of reservoirs of stoves—that of the dripping of the water onto the stove itself—is entirely obviated.

To the under side of the rim D I form a pendent ridge, F, whose lower edge rests upon the top plate of the stove, and I make the latter sloping down from the reservoir outward, as shown in Fig. 2, so that whatever water is spilled over the edges of the reservoir, in the operation of filling the same, is not permitted to run into the hot closet in the stove in which the reservoir is heated, but is conducted by the exterior edge of the ridge F, and the sloping top of the stove to the floor, the pendent character of the ridge preventing the water from passing the joint interiorly.

I claim—

A reservoir for cooking-stoves, provided at the rim with an elevated ridge, E, and a pendent ridge, F, substantially as and for the purposes specified.

In testimony of which invention I hereunto set my hand.

A. J. REDWAY.

Witnesses:

JOHN E. JONES,  
EDGAR J. GROSS.