

W. W. BREWSTER.  
 PLANING-MACHINE.

No. 192,322.

Patented June 26, 1877.

Fig. 1.

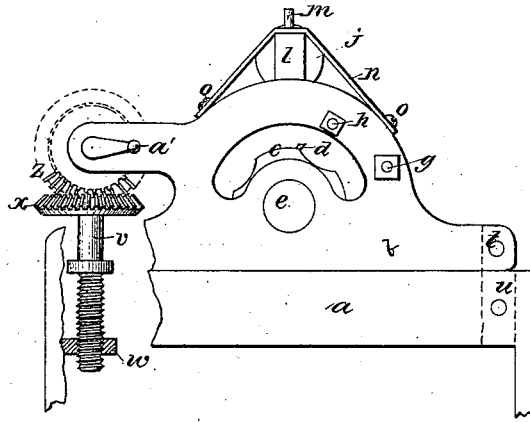

Fig. 2.

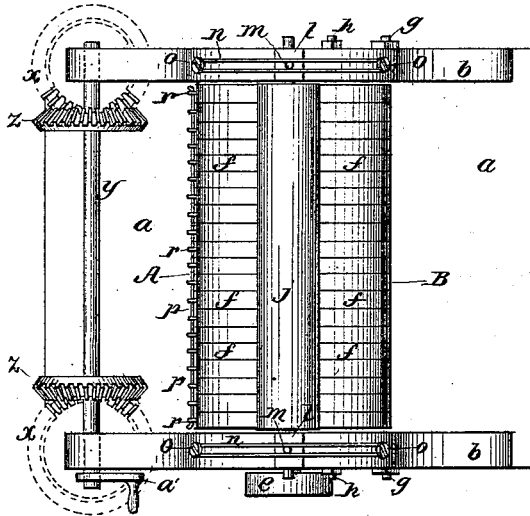
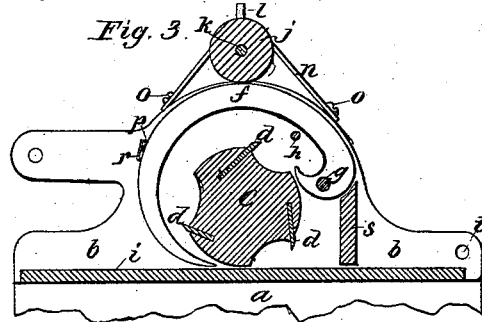

Fig. 3.



Witnesses.

Samuel D Kelley.  
 Eben Hutchinson

Inventor.

Wm W Brewster

# UNITED STATES PATENT OFFICE.

WILLIAM W. BREWSTER, OF REVERE, MASSACHUSETTS.

## IMPROVEMENT IN PLANING-MACHINES.

Specification forming part of Letters Patent No. 192,322, dated June 26, 1877; application filed October 27, 1875.

To all whom it may concern:

Be it known that I, WILLIAM W. BREWSTER, of Revere, in the county of Suffolk and State of Massachusetts, have invented new and useful Improvements in Planing-Machines, of which the following is a specification:

This invention relates to improvements in that class of planing-machines which embrace the essential principles of what is known as the "Woodworth Planer," or, in other words, planers provided with a horizontal rotary or cutting cylinder whose axis is transverse to the machine-bed; and the invention consists in a peculiar device or shield by means of which the lumber, when being planed, is held flat upon the bed, and the tendency of the rotary cutters to draw the lumber toward said cutters or upward from the bed is obviated; said shield consisting of a series of independent sections whereby a nearly uniform pressure may be imparted to all parts of warped or uneven lumber as it passes under the cutters. It also consists in an elastic pressure-roll, by means of which pressure is applied to all the sections of said shield.

In the accompanying drawings, Figure 1 is a side elevation, showing the bed, the frame in which the cutting-cylinder is mounted, the method of attaching the same to the bed, and adjusting it, and also a part of the pressure devices. Fig. 2 is a top or plan view, showing the bed, the cylinder-frame, the means of adjusting it, and the pressure devices. Fig. 3 is a vertical section taken on line A B, Fig. 2, showing a section of the bed, the cylinder frame or holder in elevation, the cylinder in section, the pressure devices partly in section and partly in elevation, and also a board in section as being planed.

In the drawings, *a* represents the bed, and *b b* the frame wherein the cutting-cylinder *c* is mounted. *d d* are the cutters; *e*, the driving-pulley or axis of cylinder; *f*, one of the sections of the pressure-shield; *g*, the pivot-rod on which sections *f* are hinged; *h*, stop-rod to arrest descent of shields *f*; *i*, board being planed; *j*, elastic pressure-roll; *k*, rod on which roll *j* is mounted; *l*, box or bearing for rod *k*; *m*, stay-rod on which box *l* slides vertically; *n*, elastic binder which forces roll *j* against shield *f*; *o o*, knobs upon which binder *n* is

secured; *p*, rod connected by staples *r* with sections *f* for raising the same; *s*, horizontal bar uniting sides *b* of cylinder-frame; *t*, pivot-rods on which cylinder-frame vibrates; *u*, bar shown by dotted lines, and which unites the cylinder-frame with the bed; *v*, elevating-screws by which the cutting-cylinder is adjusted to various thicknesses of lumber; *w*, screw-nut secured in the bed, and in which screw *v* is threaded and rotates; *x x*, miter-gears secured upon screws *v v*; *y*, horizontal shaft journaled in frame *b*, and carrying two miter-gears, *z z*, which mesh into and actuate gears *x x*; *a'*, crank secured upon shaft *y* for purpose of actuating the same.

The bed *a* may be of any suitable form. The two sides, *b b*, of the cylinder-frame, and the connecting-bar *s* may be formed of one entire iron casting, or in any manner as the experience of any person of advisory skill in such matters can readily choose and adopt. This frame at the right-hand end, as shown in Figs. 1 and 3, is pivoted by rods *t t* to the bed *a* by means of a bar, *u*, secured in bed *a*, as shown by dotted lines in Fig. 1. At the opposite or left-hand end of this frame two screw-shafts are fitted to revolve in the respective sides of the frame, being therein secured from vertical displacement by a collar formed upon the screw and the gears *x*, secured upon their upper end.

The threaded part of these screws acts in the screw-nuts *w*, secured in bed *a*, as shown in Fig. 1, where a part of the bed and cylinder-frame are shown broken away, to show the arrangement of the parts. The shaft *y* revolving in frame *b*, and actuated by means of crank *a'*, carries the gears *z z*, which mesh in gears *x*, thereby actuating screws *v* and raising or lowering the frame *b*, thereby adjusting the cutter *c*, which is journaled in the sides of frame *b b*, as shown in Fig. 1. The cylinder may be of any suitable form.

For the purpose of producing the needed pressure upon board *i*, while being planed, I employ a shield formed of a series of crescent-shaped fingers *f* pivoted upon rod *g*, which passes through frame *b b*. This series of fingers fills the space between frame *b*, and also serves as a hood or shield to retain the shavings and cause them to be drawn by an ex-

haust-current through the aperture shown in the frame *b* in Fig. 1; and to facilitate this movement the pivoted ends of the fingers are curved in near to the cylinder to cause a reflex current of air at this point.

The pivot-rod *g* and the curve of the concave line of the fingers are arranged relatively to the diameter of the cylinder and the point of contact of the cutters with the board, so that the points of the fingers can act upon the board at the nearest practicable proximity to the cutters and yet allow space for the shavings to move with the cutters until they are free to pass through the aperture in frame *b*, as stated. The rod *k*, extending across frame *b b*, checks the descent of the points of fingers *f* at the desired point, and prevents their contact with cutters *d*. To produce the requisite pressure of fingers *f* upon board *i*, the elastic roll *j* is mounted upon rod *k*, which is secured in block *l*, which latter slides freely upon pin *m* secured in frame *b*. *n n* are elastic bands acting upon blocks *l* and secured upon knobs *o o* in frames *b b*. Instead of these elastic bands, weighted levers may be employed to produce downward pressure upon roll *j*, which, by reason of its elasticity, acts upon all the

fingers *f*, thereby producing a uniform pressure upon board *i*, whether the same be level and of a uniform thickness or not.

To facilitate the raising of all of fingers *f* at once, when it is desired to expose the cylinder, and yet allow them a limited independent vertical movement, the rod *p* is secured to each finger by a staple, *r*, secured in each finger, and through which the rod loosely passes.

I claim as my invention—

1. The pressure-shield, herein described, consisting of a series of crescent-shaped sections *f*, which are pivoted behind the cutting-cylinder, and which pass over the cylinder near to its cutting-point, in the manner shown, and for the purposes specified.

2. In combination with the sectional pressure-shield, the elastic pressure-roll *j* and the pivoted and vertically-adjustable cylinder-frame *b*, constructed to operate substantially in the manner shown and for the purposes specified.

WM. W. BREWSTER.

Witnesses:

EBEN HUTCHINSON,  
EUGENE HUMPHREY.