

J. BURGESS.
SOLDERING AND HEATING FURNACE.

No. 192,360.

Patented June 26, 1877.

Fig. 1.

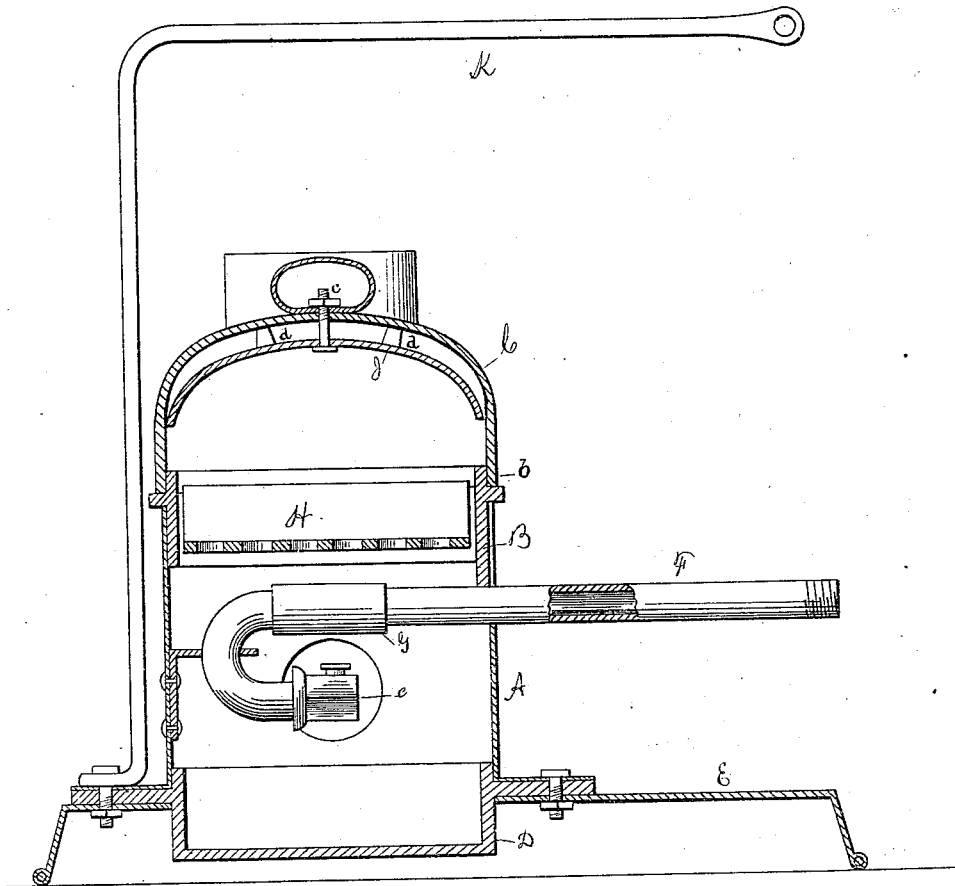

Witnesses:
A. B. Brown
A. M. Long,

Inventor,
J. Burgess.
Per A. A. Abbott.
Attorney.

J. BURGESS.

SOLDERING AND HEATING FURNACE.

No. 192,360.

Patented June 26, 1877.

Fig. 2.

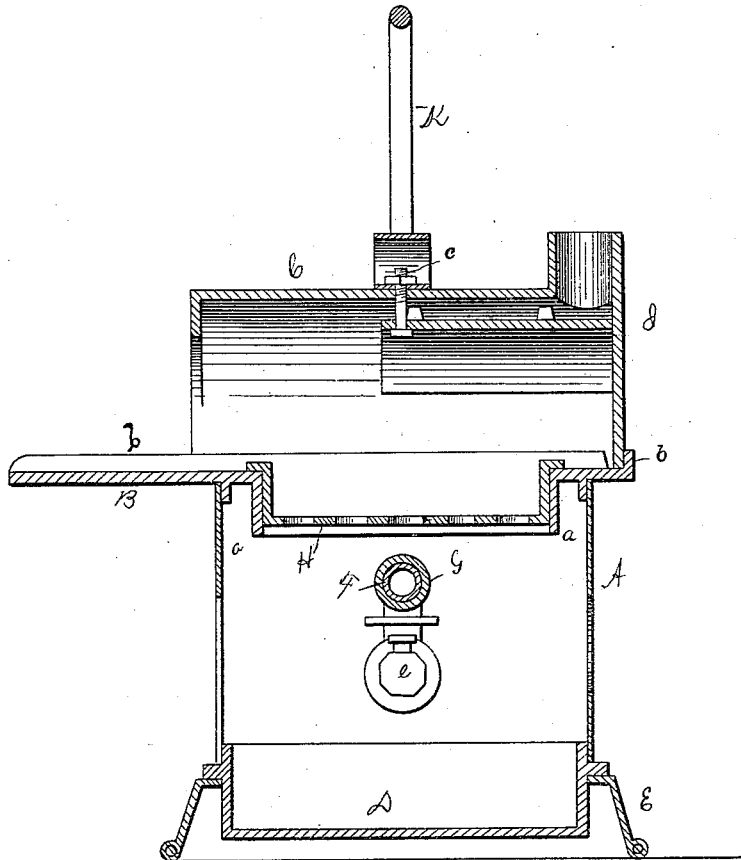

Witnesses:
H. B. Brown
A. M. Long.

Inventor:
J. Burgess
Per H. S. Abbott,
Attorney.

UNITED STATES PATENT OFFICE.

JOSIAH BURGESS, OF ZANESVILLE, OHIO.

IMPROVEMENT IN SOLDERING AND HEATING FURNACES.

Specification forming part of Letters Patent No. **192,360**, dated June 26, 1877; application filed May 12, 1877.

To all whom it may concern:

Be it known that I, JOSIAH BURGESS, of Zanesville, in the county of Muskingum and State of Ohio, have invented certain new and useful Improvements in Soldering and Heating Furnaces; and I do hereby declare that the following is a full, clear, and exact description thereof, which will enable others skilled in the art to which it appertains to make and use the same.

The nature of this invention relates to certain improvements in that class of furnaces for heating soldering-irons by the employment of naphtha or other products of petroleum for generating the heat, and is especially designed as an improvement on Letters Patent No. 145,784, granted to me December 23, 1873.

The invention consists in the special construction and arrangement of parts hereinafter fully set forth.

In order to enable others skilled in the art to which my invention appertains to make and use the same, I will now proceed to describe its construction and operation, reference being had to the accompanying drawing, forming part of this specification, and in which—

Figure 1 is a transverse vertical section through the furnace; Fig. 2, a lateral or longitudinal section of the same.

In the drawing illustrating my invention, A designates the base of the furnace, which may be made of cast or sheet iron. Upon this base is placed a body, B, which, in turn, supports the hood or cap C of the furnace.

At the bottom of the base A is placed a water-tank, D, seated in a reversed pan, E, and bolted to the base and pan immediately beneath the burner *e*, for the purpose of catching any waste fluid that may escape from the burner before the generation of gas has commenced. It is also observed that the steam generated from the water after the furnace becomes heated has a peculiar effect upon the soldering-irons, causing the tin to remain longer upon the iron than when the same iron is heated in a furnace without the water, or in a charcoal-furnace.

Through the vertical side wall of the base A is passed a tube, F, which forms the burner and gas-generating apparatus. Upon this

tube F is placed a movable sleeve, G, for protecting the tube and keeping it from being burned away by reason of the intense heat of the blaze. The said tube and burner are supported in a small bracket-like device bolted to the side of the base A.

The body B has an opening, which may be either rectangular or round, to receive a removable perforated resting-plate, H, extending downwardly to the edge of the flange *a* of the body B. This resting-plate catches the soot arising from the flame and holds the same until consumed.

The hood C is placed or held in position on the body B by side and back vertical flanges *b*, the side flanges extending back nearly to the back flange, as shown in Fig. 2, forming recesses, into which the closed end of the hood is placed.

On the under side of the hood C is placed a curved deflecting device, I, having the back side in juxtaposition with the closed end of the hood.

The deflecting device is made of cast-iron or any suitable metal, and preferably in the shape shown in Fig. 1. It is held in place by a bolt, *e*, or any other suitable device, providing a means by which the deflector may be adjusted to increase or limit the draft caused by a chimney placed on the flanges around the aperture at the back end of the hood C. The lugs *d* prevent the deflector coming in such close proximity to the hood as to entirely close the draft.

For transporting the furnace, a rod, K, is at one end bolted to the inverted pan E, as shown, and the other end attached to a band around the air or oil reservoir.

Having thus fully described my invention, what I claim as new, and desire to secure by Letters Patent, is—

1. In a furnace for heating soldering-irons, the hood C, provided with an adjustable deflecting device having lugs *d d*, as shown and described.

2. In combination with a furnace for heating soldering-irons, the combination of a hood, C, deflector I, and a perforated resting-plate, H, substantially as described.

3. In a furnace for heating soldering-irons, a body, B, constructed with flanges *a* and *b*,

substantially as described, having a rectangular or round opening, substantially in the manner and for the purpose specified.

4. In a furnace for heating soldering-irons, a water-tank, D, set in a recessed inverted pan, E, in combination with the base A, body B, and hood C, substantially as described.

5. In a furnace for heating soldering-irons, the combination of the hood C, deflector I, body B, perforated resting-plate H, base A, water-tank D, inverted pan E, and handle K,

all arranged, constructed, and operating substantially in the manner and for the purpose set forth.

In testimony that I claim the foregoing as my own I affix my signature in presence of two witnesses.

JOSIAH BURGESS.

Witnesses:

DANIEL B. GARY,
JOHN A. GREEN.