

J. POETZ.
WALKING-CULTIVATOR.

No. 192,387.

Patented June 26, 1877.

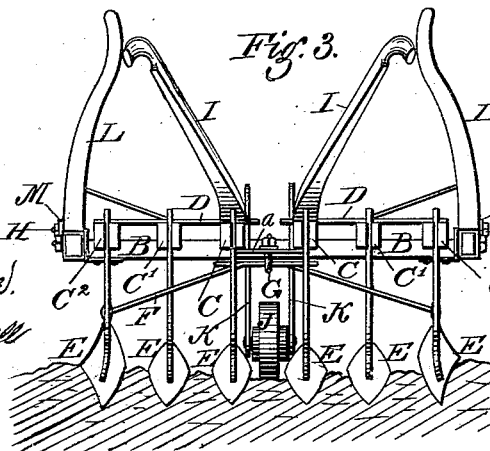
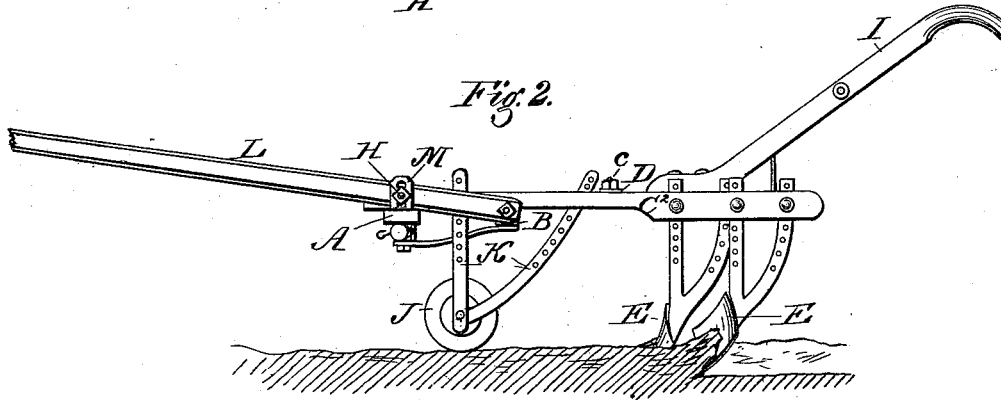
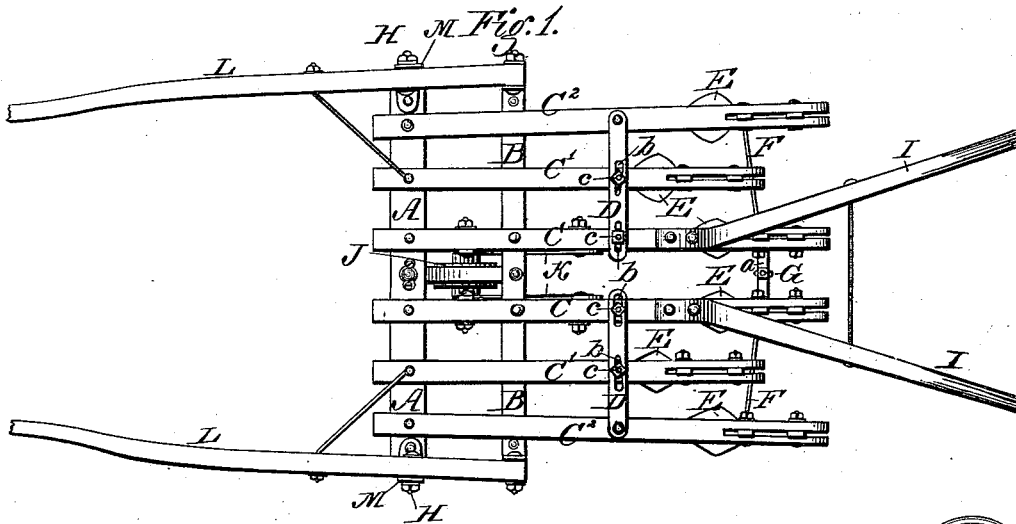

Witnesses:
Will H. Dodge.
Donn S. Twitchell

Inventor:
John Poetz
By his atty
Dodge & Co.

UNITED STATES PATENT OFFICE

JOHN POETZ, OF SHAKOPEE, MINNESOTA.

IMPROVEMENT IN WALKING-CULTIVATORS.

Specification forming part of Letters Patent No. **192,387**, dated June 26, 1877; application filed March 1, 1877.

To all whom it may concern:

Be it known that I, JOHN POETZ, of Shakopee, in the county of Scott and State of Minnesota, have invented certain Improvements in Walking-Cultivators, of which the following is a specification:

My invention relates to that class of one-horse walking-cultivators in which a number of adjustable shovels are employed; and consists in certain peculiarities of construction hereinafter described.

Figure 1 represents a top-plan view of my implement; Fig. 2, a side elevation of the same; Fig. 3, a rear elevation of the same.

A and B represent two parallel cross-bars, and C C two beams or drag-bars arranged parallel with each other, and secured at their forward ends rigidly to the bars A B, and also connected at their rear ends by a metal cross-bar, *a*. (Shown in Figs. 1 and 3.) C¹ and C² represent four adjustable beams or drag-bars arranged outside of the rigid middle beams, and pivoted at their forward ends to the front cross-bar A, in order that their rear ends may be moved laterally.

The beams are prevented from moving laterally when in action by means of metal bars D, which are hinged at their outer ends to the outside beams C², and extended across the inside beams, and provided with slots *b*, through which the bolts *c* are passed into the beams, as shown in Fig. 1. Each beam has its rear end provided with a shovel, E, having two arms or standards passed up through a slot in the beam and secured by bolts. The two standards of each shovel are provided with a series of pin or bolt holes, as shown in Fig. 2, to admit of the shovels being raised, lowered, and inclined, as circumstances may require. The shovels of the outside beams are inclined sidewise, or given a lateral obliquity in opposite directions, and are made interchangeable, so that they may be caused to throw the earth inward or outward, as the condition of the plants and the state of the ground may render desirable.

In order to sustain the two outside shovels against the lateral resistance of the earth, and to give the implement additional stiffness, braces F are connected to the standards

of said shovels, and passed thence inward through an eyebolt or equivalent clamp, G, mounted on the cross-bar *a*, by which the central beams are connected. On the rear ends of the two central beams C C I secure two rigid handles, I, by means of which the operator, walking behind the machine, can govern and control its movements. Under the forward end of the machine I mount a sustaining wheel or roller, J, carried by arms or standards K, secured in an adjustable manner to the central beams C, as shown in all the figures. Upon the front end of the machine I mount two rigid adjustable shafts or thills, L, to which to connect the horse or other draft-animal.

As shown in the drawings, the thills are pivoted at their rear ends to the ends of the bar B, and held in position by means of clamping-bolts H, which are passed through vertically-slotted plates M on the bar A, and into the thills, as in Figs. 1 and 2, so that the thills may be adjusted vertically, as desired.

By properly adjusting the thills and the wheel the machine is caused, when in action, to balance on the wheel in such manner that the shovels are caused to travel at the proper depth in the ground, and the operator is enabled to control the movement of the machine with ease.

The fact that the thills, beams, and handles are all connected rigidly, while the machine is sustained by the wheel under its front end, admits of the machine being handled with great ease, and of its being balanced on the front wheel by the weight of the draft-animal attached to the thills. By the slotted bars D and the braces F the beams are held securely and rigidly, and at the same time their ready adjustment is permitted in such manner that the distance between the shovels may be varied at will.

Taken as a whole, the machine will be found cheap, durable, and serviceable, capable of performing every operation required, and easy to handle.

Having thus described my invention, what I claim is—

1. The combination of the cross-bars A and B, the rigid beams C, and adjustable beams

C¹ C², provided with the shovels E, the rigid thills L, rigid handles I, and wheel J, as shown and described.

2. In combination with the oblique outside shovels E attached to the swinging beams, the braces F and clamping device G, as shown.

3. In a cultivator, the combination of two cross-bars, A B, having thills L attached, two parallel rigid beams, C, attached to the cross-

bars, connected by a bar, a, and provided with rigid handles I and outside swinging beams C¹ C², pivoted to the bar A, and held by the slotted bars D and bolts e, as shown.

JOHN POETZ.

Witnesses:

T. D. STRAIT,

E. MCNEIL.