

F. FEARON.

STOP-MOTION ATTACHMENTS FOR SPOOLING-MACHINES.

No. 192,424.

Patented June 26, 1877.

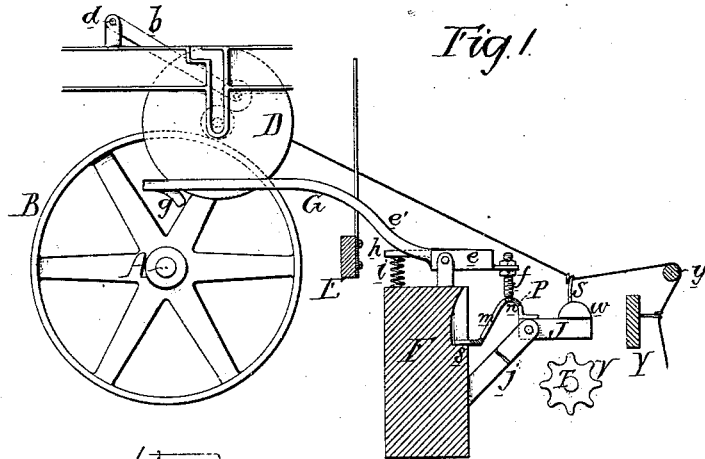

Fig. 1.

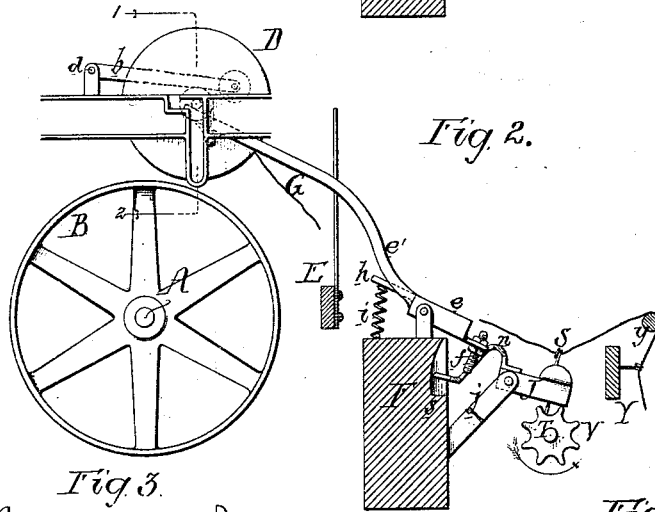

Fig. 2.

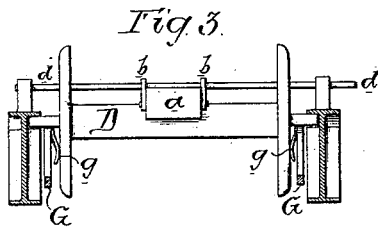

Fig. 3.

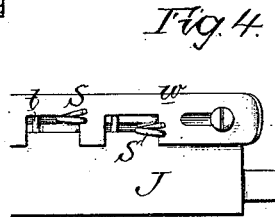
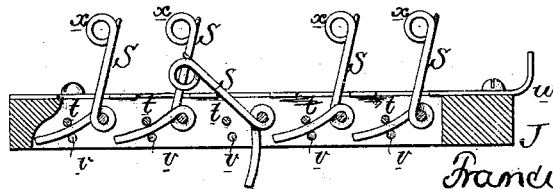

Fig. 4.

Fig. 5.



Witnesses.

Harry Crawford.  
John Dupont.

Inventor  
Francis Fearon  
by his Attorneys  
Howson & Son

# UNITED STATES PATENT OFFICE.

FRANCIS FEARON, OF PHILADELPHIA, PENNSYLVANIA, ASSIGNOR TO  
THOMAS DOLAN AND R. WILLIAMS, JR., OF SAME PLACE.

## IMPROVEMENT IN STOP-MOTION ATTACHMENTS FOR SPOOLING-MACHINES.

Specification forming part of Letters Patent No. 192,424, dated June 26, 1877; application filed  
January 29, 1877.

*To all whom it may concern:*

Be it known that I, FRANCIS FEARON, of Philadelphia, Pennsylvania, have invented a new and useful Improvement in Stop-Motion Attachments for Spooling-Machines, of which the following is a specification:

The object of my invention is to construct a sensitive stop-motion for spooling-machines; and this object I attain in the manner which I will now proceed to describe, reference being had to the accompanying drawing, in which—

Figure 1 is a side view, partly in section, of the operating parts of my improved stop mechanism, the frame-work of the machine being omitted; Fig. 2, the same in a different position; Fig. 3, a transverse section on the line 1 2, Fig. 2; and Figs. 4 and 5, enlarged views of parts of the machine.

A is the main shaft of a spooling-machine, and on this shaft is a drum, B, which drives the spools D by contact of its periphery with the threads wound on the said spool, proper frictional contact of the two being insured by a friction-roller, *a*, carried by arms *b* hung to a transverse shaft, *d*, said roller resting on top of the threads on the spool.

E is the usual bar for laying the threads evenly on the spool, and F is a bar, to lugs on which are hung two levers, G, arranged one at each side of the spool D, and each lever having a short arm, *e*, carrying an adjustable screw, *f*, and a long arm, *e'*, the outer end of which is adjacent to the flange of the spool, and is bent so as to form a spring-finger, *g*. Each lever G is also provided with a finger, *h*, which is acted upon by a coiled spring, *i*, in the manner described hereinafter.

To bearings *j* projecting from the bar F is hung a frame, J, secured to or forming part of which is a bent plate, P, the latter having a slot, *m*, and immediately adjacent to the same a bearing-surface, *n*, which, when the parts are in the position shown in Fig. 1, is immediately beneath and supports the screws *f* of the levers G.

The extent to which the bearing-surface *n* projects beneath the screws *f* depends upon the vertical position of the latter, by varying which, therefore, the sensitiveness of the machine can be increased or diminished at pleasure.

The end of the plate P moves in a recess in the bar F, and its downward movement, and consequently the upward movement of the frame J, is limited by a shoulder, *s*, on the bar.

Within a slot in the frame J are hung a number of bell-crank levers, S, (five in the present instance,) each lever being composed, preferably, of a bent wire, and having at the upper end an eye, *x*, for the passage of a thread, and immediately beneath the frame J, and in line with the levers S of the same, is a shaft, T, carrying a fluted roller, V.

Across the slot in the frame J extend pins *t*, against which the short arms of the levers S, when in use, are caused to bear by the tension of the threads upon their long arms, and in the sides of the frame, beneath these pins, are formed openings *v*, through which pins may be inserted, so as to hold one or more of the levers S rigidly in position when its use is not required.

On the top of the frame J is a sliding plate, *w*, having slots, through which project the levers, the object of this plate being to restore a lever to its normal position after it has fallen, owing to the breaking of a thread.

The operation of the device is as follows:

Supposing the parts to be in the position shown in Fig. 1, the frame J being in a horizontal position, and the bearing-surface *n* of the plate P supporting the short arms of the levers G, and maintaining the spring-fingers at the ends of their long arms below the flanges of the spool, the threads pass from the eyes on the guide-bar Y over the roller *y*, and thence to the spool through the eyes of the levers S, which are maintained by the threads in an elevated position, with their short arms against the pins *t*.

Should a thread break, its lever instantly falls, as shown in Fig. 5, and its short arm will be in the path of the fluted roller V, revolving in the direction of the arrow, and one of the ribs of this roller will press against the said arm with such effect that the frame J will be turned on its pivot, and thus withdraw the bearing-surface *n* of the plate P from beneath the screws *f* of the levers G, the former then, owing to the action of the springs *i*, dropping into the slot *m* of the plate, and thus causing such an elevation of the long arms of

the levers that they strike the journals of the spool, and lift the same clear of the driving-drum B, the spring-fingers *g*, at the same time, bearing with such force against the flanges of the spool that they act as brakes, and check the tendency of the spool to revolve, owing to the momentum it had acquired.

The sliding plate *w* is now so operated as to restore the fallen lever S to its normal position, when one of the broken ends of the thread is passed through its eye and spliced to the other end. The long arms of the levers G are then depressed and the frame J raised to a horizontal position, so as to bring the bearing-surface *n* of the plate P under the ends of the screws *f*, this position being determined by the end of said plate D coming in contact with the shoulder *s* of the bar F.

The machine is then in operating condition.

Although I have shown in the drawing but one spool and its stop mechanism, it should be understood that a number of them are arranged side by side in a frame, across which, from end to end, extend the shafts A and T, which are provided with as many drums B and fluted rollers V as there are spools, the shafts rotating constantly, so that the stoppage of one spool does not affect the rest.

One of the principal advantages of my invention, irrespective of its sensitiveness and rapid operation, is that it can be applied to the spooling-frames at present in use without requiring any change in their parts, so that the

expense incident to constructing an entirely new machine is overcome.

I claim as my invention—

1. The combination of the driving-drum B and spool D, the fluted roller V, and the pivoted frame J, its levers S and plate P, having a supporting-strip, *n*, with the spring-levers G, adapted to raise the spool, substantially as set forth.
2. The combination of the driving-drum B and spool D with the levers G and their spring-fingers *g*, as described.
3. The combination of the pivoted frame J, having attached thereto the plate P, which has a supporting-strip, *n*, with the levers G and their adjustable screws *f*, substantially as specified.
4. The combination of the frame J, having openings *v*, with the levers S and pins *t*, as and for the purpose set forth.
5. The combination of the levers S with the frame J and its sliding plate *w*, substantially as described.
6. The combination of the pivoted frame J, its plate P, and the levers G with the bar F, having shoulder *s*, as set forth.

In testimony whereof I have signed my name to this specification in the presence of two subscribing witnesses.

FRANCIS FEARON.

Witnesses:

JOS. P. TRUITT,  
WALTER S. WRIGHT.