

F. KEISER.

AXLE-BOX.

No. 192,436.

Patented June 26, 1877.

Fig 1.

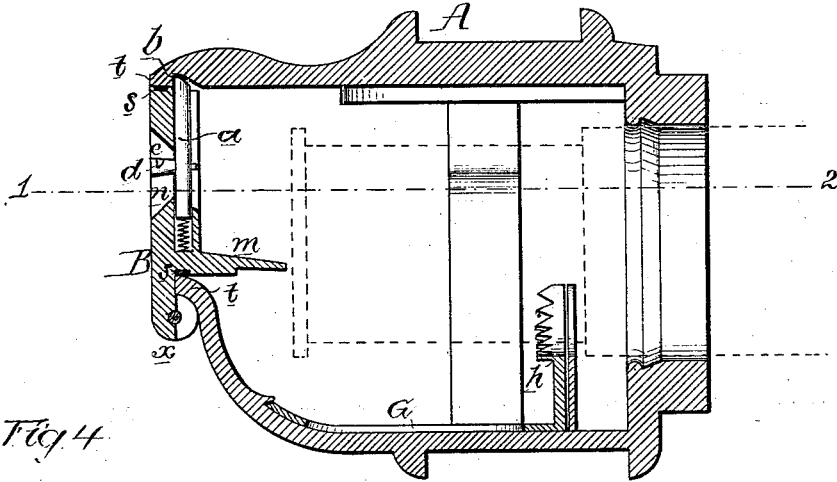

Fig 4.

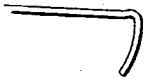

Fig 2.

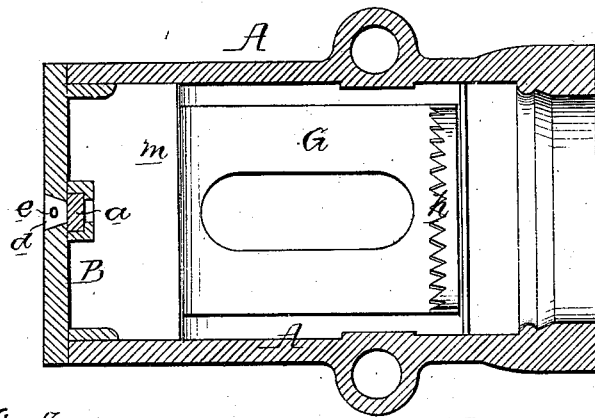
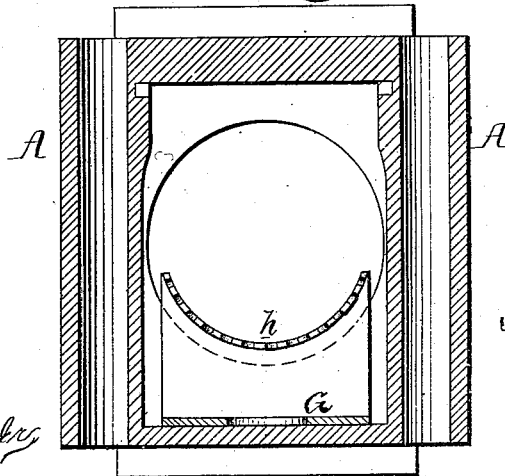

Fig 3.



Witnesses
Henry Bowman
John K. Rupertus.

Inventor
Frenz Keiser
by his Attorneys
Howson and

UNITED STATES PATENT OFFICE.

FLORENZ KEISER, OF POTTSTOWN, PENNSYLVANIA, ASSIGNOR OF ONE-HALF HIS RIGHT TO HENRY G. KULP, OF SAME PLACE.

IMPROVEMENT IN AXLE-BOXES.

Specification forming part of Letters Patent No. **192,436**, dated June 26, 1877; application filed April 7, 1877.

To all whom it may concern:

Be it known that I, FLORENZ KEISER, of Pottstown, Montgomery county, and State of Pennsylvania, have invented a new and useful Improvement in Axle-Boxes, of which the following is a specification:

The object of my invention is to furnish an axle-box with a door which can be readily opened and closed, and to make provisions for the retention of the usual absorbent material in the box within proper limits.

In the accompanying drawing, Figure 1 is a vertical section of my improved axle-box; Fig. 2, a sectional plan on the line 1 2; and Fig. 3, a transverse section.

The body of the box is of substantially the same form and construction as those in common use. The front, however, is provided with a door, B, of special construction, and having special appliances. The lower edge of this door is hinged at *x* to lugs on the box, and is provided with a guided spring-bolt, *a*, the upper beveled end of which is arranged to catch into a recess, *b*, in the top of the box.

A pin, *d*, projects from the front of the latch through a slot, *n*, in the door, the slot being countersunk or enlarged on the outside of the door for the purpose described hereafter.

The pin *d* should not extend beyond, or much beyond, the outer face of the door, otherwise the latch might be disturbed by any object accidentally coming in contact with the said pin.

I make a small orifice, *e*, in the top of the pin D for the reception of the end of an instrument like that of which one end is shown in Fig. 4.

The attendant, whose duty it is to examine the boxes, armed with this instrument, inserts the hooked point into the orifice *e*, draws down the spring-bolt, pulls the door open, and permits it to fall down.

When he desires to close the door he uses the same instrument, first for raising the said door, and finally for pushing it with the force necessary to insure the self-catching of the bolt, the enlargement of the slot *n* affording a convenient lodgment for the hooked end of the instrument in thus closing the door.

From the inside of this door projects a flange, *m*, nearly as far as the end of the journal of the axle, which is shown by dotted lines, and laterally from side to side of the box. The object of this flange is to retain the absorbent material usually placed in the box within proper limits.

On opening the door this material will be exposed for such treatment by the attendant as circumstances may demand; and on closing the door the flange will compress the material to its proper position and retain it there.

The door B is provided with leather strips *s*, which bear against the portions *t* of the box and make a tight joint, so as to prevent the entrance of dust or dirt into the interior of the box, and the escape of oil from the same.

By using these strips *s*, also, I am enabled to make the door itself somewhat less in height than the opening in the front of the box, so that it may be readily thrust into a position to insure the catching of the latch *a*, which would be difficult if the door itself were fitted tightly to the opening. Moreover, the strips prevent the possibility of injury to the catch by the jarring contact of metal at the top of the door when the latter is forcibly closed.

In the bottom of the box is fitted a plate, G, at the rear of which is an upwardly-projecting flange, *h*, the upper edge of the latter being concave, as shown in Fig. 3, as to be adapted to the journal, with which it is nearly in contact.

The concave upper edge of the flange *h* is armed with horizontal sharp teeth, which tend to retain the absorbent material within proper limits at the rear portion of the box, while the flange *m* performs the same duty at the front portion of the same.

The plate G is so lodged in the bottom of the box that it cannot be disturbed when the journal is in place.

I claim as my invention—

1. The combination, in an axle-box, of the door B, hinged at its lower edge to the front of the box, with a spring-latch, *a*, and packing-strips *s*, as set forth.

2. The combination of the spring-latch *a* and its pin *d*, having an opening, *e*, with the

door B, and the enlarged slot *n*, in the same, all as described, for the purpose specified.

3. The combination, in an axle-box, of a detachable plate, G, provided with the teeth for the retention of the absorbent material in the box, as described.

In testimony whereof I have signed my name

to this specification in the presence of two subscribing witnesses.

FLORENZ KEISER.

Witnesses :

AMOS BLOWER,
J. K. SHANER.