

J. McADAMS.
RULING-MACHINE.

No. 192,444.

Patented June 26, 1877.

Fig. 1.

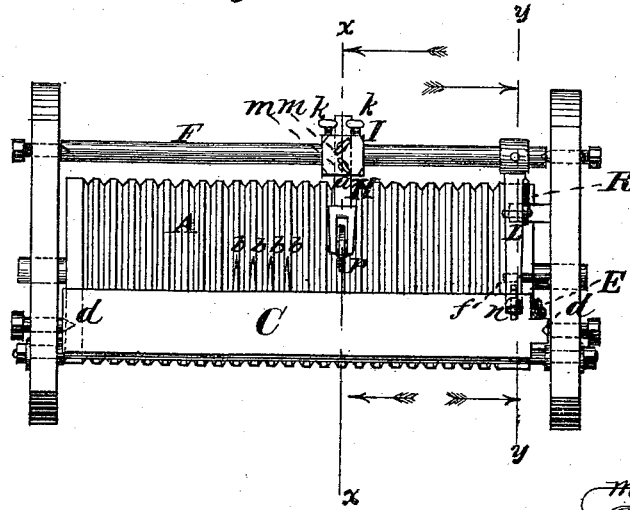

Fig. 2.

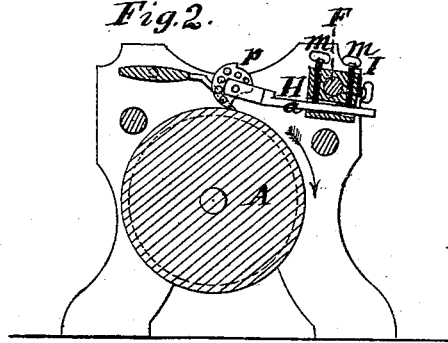

Fig. 4.

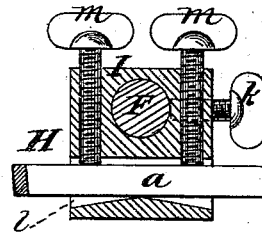
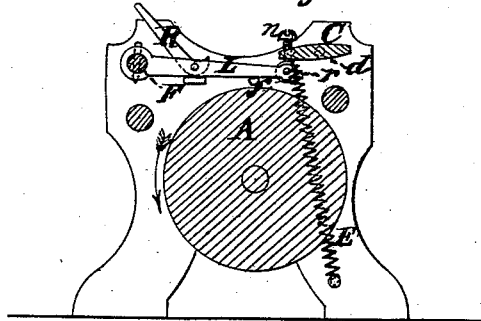

Fig. 3.



Witnesses
John Becker
Fred. Hayes

Inventor
John M. Adams
By his Attorneys
Brown & Allen

UNITED STATES PATENT OFFICE.

JOHN McADAMS, OF BROOKLYN, NEW YORK.

IMPROVEMENT IN RULING-MACHINES.

Specification forming part of Letters Patent No. 192,444, dated June 26, 1877; application filed November 23, 1876.

To all whom it may concern:

Be it known that I, JOHN McADAMS, of Brooklyn, in the county of Kings and State of New York, have invented an Improvement in Pen-Lifters of Ruling-Machines; and I do hereby declare that the following is a full, clear, and exact description of the same, reference being had to the accompanying drawing, which forms part of this specification.

My invention relates to machines for ruling paper, and is more particularly applicable to a machine for improvements on which Letters Patent of the United States, No. 104,047, dated June 7, 1870, were granted to me; but it may be applied to other ruling-machines.

My invention consists in means whereby the ruling-pens are caused to act upon the paper independently of the pen-lifter, and whereby the pens may be adjusted to act with the proper pressure upon the paper to be ruled, independently of the pen-lifter, and perform their work more accurately and effectively, and which, by reason of increased steadiness of the pens, enable the machine to be run at higher speed, while the pen-lifter may be got at with greater facility for regulation or repair. The invention further consists in means whereby the pen-lifter is rendered adjustable on the pen-lifter shaft, to regulate the pressure of the cam-roller of the pen-lifter on the cylinder.

Figure 1 in the drawing is a top view of a portion of a ruling-machine, embracing my improvements. Fig. 2 is a vertical cross-section of the same on the line *x x*, Fig. 1. Fig. 3 is a vertical cross-section of the same on the line *y y*, Fig. 1. Fig. 4 is a sectional detail of a portion of the pen-lifter.

A in the drawing represents the cylinder of a ruling-machine, around which the paper passes during the process of ruling. Parallel grooves are formed circumferentially in the roller *A*, and the ruling-pens *b* are set to press upon the paper, the paper being drawn smooth on said roller. The pens *b* are fixed in a pen bar or clamp, *C*, Figs. 1 and 3. The pen bar or clamp is pivoted to the frame of the machine at *d*, and to the front end of said pen-bar is attached a spring, *E*, which draws down the said front edge of the pen-bar, and applies the pens to the paper to be ruled.

At a suitable distance from the pen-bar *C* is also pivoted to the frame of the machine a rock-shaft, *F*, to which rock-shaft is attached the pen-lifter *H*, Figs. 1, 2, and 4. The said pen-lifter is essentially the same as that described in the specification of Letters Patent No. 104,047, granted to me June 7, 1870, above referred to, but my method of adjusting the said pen-lifter on the rock-shaft *F* is new, and possesses important advantages. The arm *a* of said pen-lifter *H*, Figs. 1 and 2, is passed through a slotted clamping-block, *I*, fastened to the rock-shaft *F* at any desired part of the same by set-screws *k*. The under side of the slot *l*, Fig. 4, in the clamping-block *I*, which receives the arm *a* of the pen-lifter, has the form of a double-inclined plane, the higher part of which is in the middle, and acting at opposite sides of the said higher part of said double-inclined plane are set-screws *m m*, by which the said arm *a* may be set at either a right angle or at such an obtuse or acute angle with the said clamping-block as may be required to adjust the cam-roller *p*, Figs. 1 and 2, on the surface of the cylinder *A* in proper relation with the rock-shaft *F*.

To one end of the rock-shaft *F* is attached a lever, *L*, Figs. 1 and 3, one end of which reaches under the front edge of the pen-bar *C*, and is provided with a friction-roller, *r*. The rock-shaft *F*, when rocked by the pen-lifter *H*, moves the lever *L* to raise the front edge of the pen-bar *C* against the action of the spring *E*, and to lift the pens from the paper, in order to leave the proper unruled spaces for headings, &c. The downward movement of the lever *L* is limited by a stop, *f*, Figs. 1 and 3, and a cam-lever, *R*, is used to raise and hold the said lever *L*, and with it the front edge of the pen-bar, and the pens, when it is desired to intermit the operation of said pens.

The adjustment to secure the proper downward movement of the front edge of the pen-bar *C* is accomplished by a set-screw, *n*, Figs. 1 and 3, passing through a thread in the pen-bar *C*, the lower extremity of said set-screw resting on the friction-roller *r*.

By these means all the objects and advantages hereinbefore set forth are secured.

I claim—

1. The combination, with the oscillating pen-bar C, of the pen-lifter H, and its independent rock-shaft F, and a connection between said pen-bar and rock-shaft, substantially as and for the purpose herein described.

2. The combination of the slotted clamping-block I, having the bottom of the slot in the form of a double-inclined plane, the adjusting-screws *m m*, and the pen-lifter H, substantially as and for the purpose set forth.

3. The combination, with the lever L and the pen-bar C, of the friction-roller *r*, the set-screw *n*, and the stop *f*, for the adjustment of said pen-bar, substantially as and for the purpose described.

JNO. McADAMS.

Witnesses:

BENJAMIN W. HOFFMAN,
FRED. HAYNES.