

A. K. RIDER.
ROLLERS FOR SLIDING-DOORS.

No. 192,455.

Patented June 26, 1877.

Fig. 1.

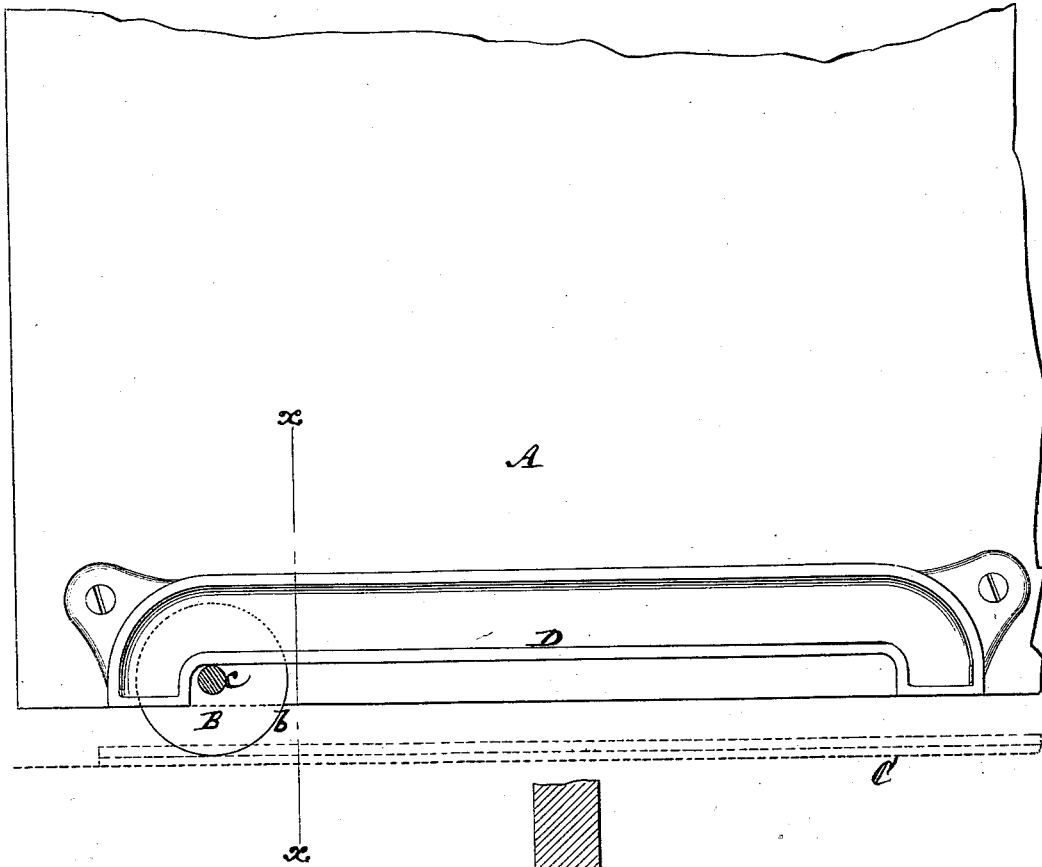
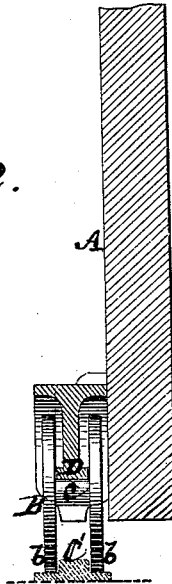

Fig. 2.



Witnesses
John Becker
J. W. Haynes

Alexander K. Rider
by his Attorneys
Brown & Allen

UNITED STATES PATENT OFFICE.

ALEXANDER K. RIDER, OF WALDEN, NEW YORK.

IMPROVEMENT IN ROLLERS FOR SLIDING DOORS.

Specification forming part of Letters Patent No. **192,455**, dated June 26, 1877; application filed December 16, 1876.

To all whom it may concern:

Be it known that I, ALEXANDER K. RIDER, of Walden, in the county of Orange and State of New York, have invented a new and useful Improvement in Roller Attachments or Devices for Sliding Doors, Gates, and other like purposes; and I do hereby declare that the following is a full, clear, and exact description of the same, reference being had to the accompanying drawing, which forms part of this specification.

The object of this invention is to provide a cheap, yet durable and efficient, rolling support for sliding doors or gates. To these ends I use a compound or differential wheel or roller of spool-like form, having two comparatively large outer heads of equal diameter, connected by an intermediate axle-like hub of much smaller diameter. The heads of this compound wheel or roller form treads for the latter upon a stationary rail or track, while the axle-like hub between said heads forms a bearing for a hanger, attached to the sliding door or gate, and which is constructed to enter between the heads of the compound wheel or roller, to rest upon and travel or slide over. This construction of a roller-support for doors or gates does away with the necessity of any outside journals for the compound wheel or roller, as also a close sheave or case for the same, and gives a very perfect and steady bearing for the door or gate.

Figure 1 represents a partly sectional side view of a sliding door or gate, in part, having my invention applied to its bottom, but which may be applied with equal advantage to the top of the door or gate. Fig. 2 is a transverse vertical section on the line *x x*.

A is the sliding door or gate, which is supported at its bottom, near either end, also intermediately of its ends, if desired, by compound or differential wheels or rollers B, which travel on a stationary track, C, of any suitable form in its transverse section. Each of these compound wheels or rollers is composed of outer and parallel heads *bb* of equal and comparatively large diameters, and a connecting or intermediate axle-like hub, *c*, of much small-

er diameter. The intermediate hub forms a bearing for the door or gate on the compound wheel or roller B, said door or gate being supported by or made to bear down on said hub, with freedom of travel over the latter, by means of a bearing-hanger, D, secured to the front or back of the door or gate, and constructed to enter down within the heads or treads *b b* of the wheel or roller. The length of the bearing portion of the hanger D need only be of the same relative proportion to the length of the track C as the diameter of the hub *c* is to the diameter of the heads or treads *b b*; but no claim is here made to a mere differential roller for supporting the door or gate. The support of the door or gate, however, upon a central hub or reduced intermediate portion of a loose compound wheel or roller, having duplicate heads or treads at a distance apart outside of said central hub, not only secures a very steady and perfect run for the door or gate, but a close sheath or case and outside journals for the compound wheel or roller may be dispensed with.

To adapt the invention to an overhead support of the door or gate, it is only necessary to arrange the stationary track C above the upper edge of the door or gate, and to attach, by uprights secured to the latter, the bearing-hanger D at a suitable elevation above the fixed track to apply the differential or compound wheel or roller B, as hereinbefore described.

I claim—

The loose differential roller B, having duplicate heads or treads *b* at a distance apart outside of the central hub *c*, which is of a diameter less than the heads or treads *b*, for operation in connection with a fixed track, and a hanger, D, attached to a door or gate, and having a bearing-surface resting upon and traveling over the central hub of the loose roller, substantially as described.

ALEXR. K. RIDER.

Witnesses:

JAMES GOWDY,
ALEX. VAN KEUREN.