

F. P. SHOREY.
 CAR-COUPLING.

No. 192,464.

Patented June 26, 1877.

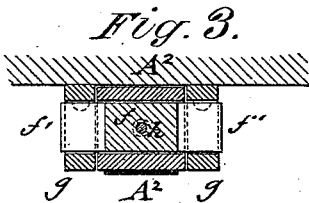
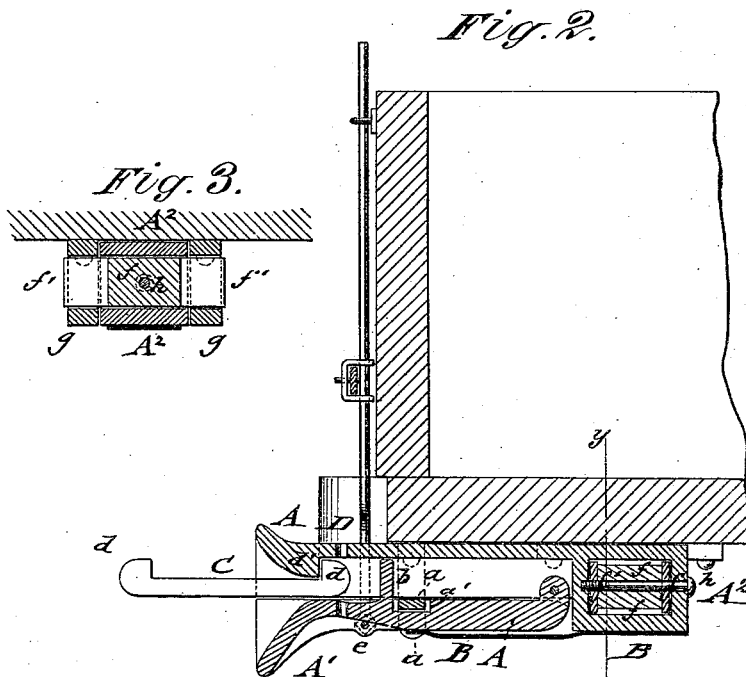
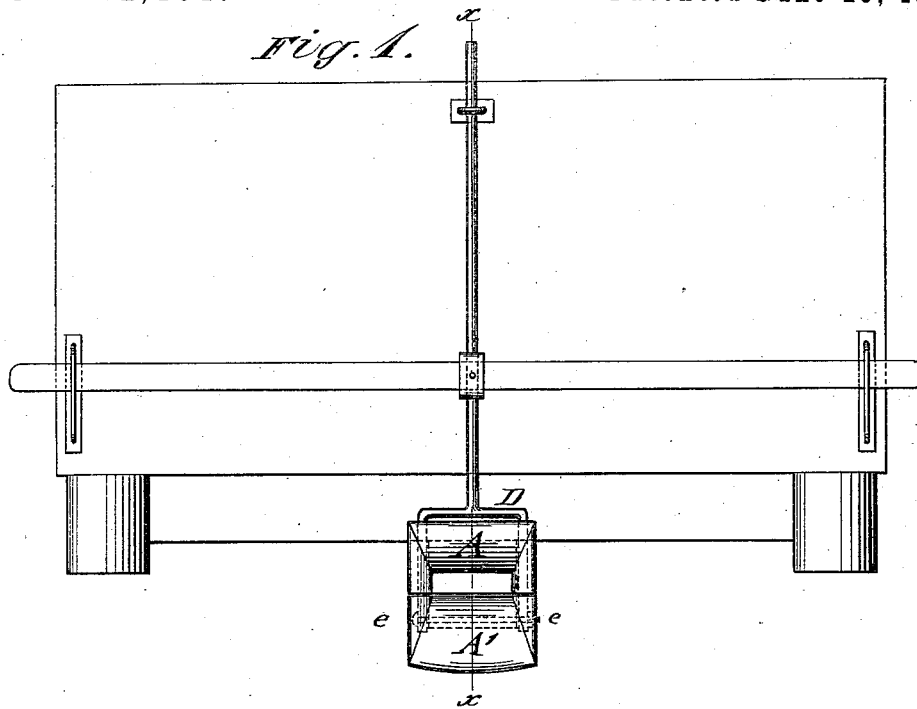

WITNESSES:

H. Rydquist
J. H. Scarborough.

INVENTOR:

F. P. Shorey.

BY

Munnell

ATTORNEYS.

UNITED STATES PATENT OFFICE.

FRANK P. SHOREY, OF AUBURN, NEW YORK.

IMPROVEMENT IN CAR-COUPINGS.

Specification forming part of Letters Patent No. 192,464, dated June 26, 1877; application filed April 9, 1877.

To all whom it may concern:

Be it known that I, FRANK P. SHOREY, of Auburn, in the county of Cayuga and State of New York, have invented a new and Improved Car-Coupling, of which the following is a specification:

In the accompanying drawing, Figure 1 represents a front view of my improved car-coupling; Fig. 2, a vertical longitudinal section of the same on the line *x x*, Fig. 1; and Fig. 3, a vertical transverse section of the cushioning device of the draw-head on line *y y*, Fig. 2.

Similar letters of reference indicate corresponding parts.

The invention relates to an improved automatic car-coupling that locks the link in reliable manner without necessitating the going between the cars to hold the link, and which may be uncoupled with great facility at any moment.

The invention will first be described in connection with the drawing, and then pointed out in the claim.

In the drawing, A represents a draw-head of the customary shape, but split horizontally into two sections, of which the upper fixed section is guided in a suitable band, *a*, of the car-frame, and cushioned at the rear end to provide for the concussions of the draw-heads.

The lower movable section A¹ is pivoted at its rear end to the upper section, and forced up tightly against the upper section by a strong band-spring, B, that is attached at the rear end to the upper section, and bearing by its free end on the under side of the lower swinging section.

The front ends of both sections are made to form a curved or tapering mouth, the end of the lower section being made to flare downward in a greater degree, for the purpose of taking up and guiding the coupling-link into the cavity of the draw-head. Back of the flaring front end the section A¹ is dished or concaved, as shown in Fig. 2, to facilitate the uncoupling of the coupling-link when one car is thrown off the track.

The lower section A¹ has a cross-plate, *b*, at suitable distance back of the mouth, against which the coupling-link strikes when far enough at the inside of the draw-head. The

swinging lower section A¹ is prevented from vibrating or shaking laterally by extending the front guide-band *a* downward along the sides of section A¹, the cross part of the band extending below the upper section in a recess, *a'*, of the lower section, the recess being of such length as to provide for the forward motion of the draw-head by the strain thereon, and for the backward motion by the concussion.

The coupling-link C is made of a solid bar, with rounded-off and hook-shaped ends or catches *d* at the ends, that engage a hook or shoulder, *d'*, of the upper section, so as to interlock therewith as soon as the link has passed back of the same. The pressure of the entering link forces the swinging lower section down, and admits the entrance of the head of the link until the head interlocks with the shoulder of the upper section, the link being then tightly retained in coupled position on the upper section by the pressure of the lower section thereon.

Both the upper and lower sections are provided with pin-holes to admit the coupling of the draw-head with the common pin and link. The dishing of the lower section, in connection with the rounded head of the coupling-link, facilitates the twisting of the link for uncoupling when any one car is thrown off the track.

The uncoupling is performed by means of a stirrup, D, that is connected by a cross-bolt, *e*, to lugs of the lower draw-head. The stirrup, and thereby the lower section, is lowered by a vertical rod, or by swinging side rods from the platform or side of the car, as desired. The coupling-link is thereby so released from the upper section as to clear the draw-head and uncouple the link. Thus a simple and reliable coupling device that couples and uncouples with cars having platforms of different heights in easy manner, and without danger to the attendant, is provided.

The cushioning device of the upper section is made by placing a rubber block or other spring, *f*, into the box-shaped rear end A² of the upper section, and connecting the same, by cross-plates *f'* at both ends of the cushioning-spring, with guide-bearers *g* at both sides of the box-shaped part A², so as to provide

for the strain thereon, as well as for the concussion of the draw-head. A screw-bolt, *b*, at the rear end of the box-shaped part *A*², passes through the same, the cross-plate, and the cushioning spring, so as to secure the rigid position of the cushioning device.

Having thus described my invention, I claim as new and desire to secure by Letters Patent—

The combination, with swinging section *A*¹, of the front guide-band *a*, extended downwardly along its sides, and provided with a cross part extending into recess *a'*, as shown and described, to prevent lateral vibration.

FRANK P. SHOREY.

Witnesses:

C. SEDGWICK,
PAUL GOEPEL.