

Z. W. SMITH.
STANCHION.

No. 192,466.

Patented June 26, 1877.

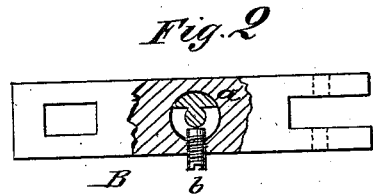
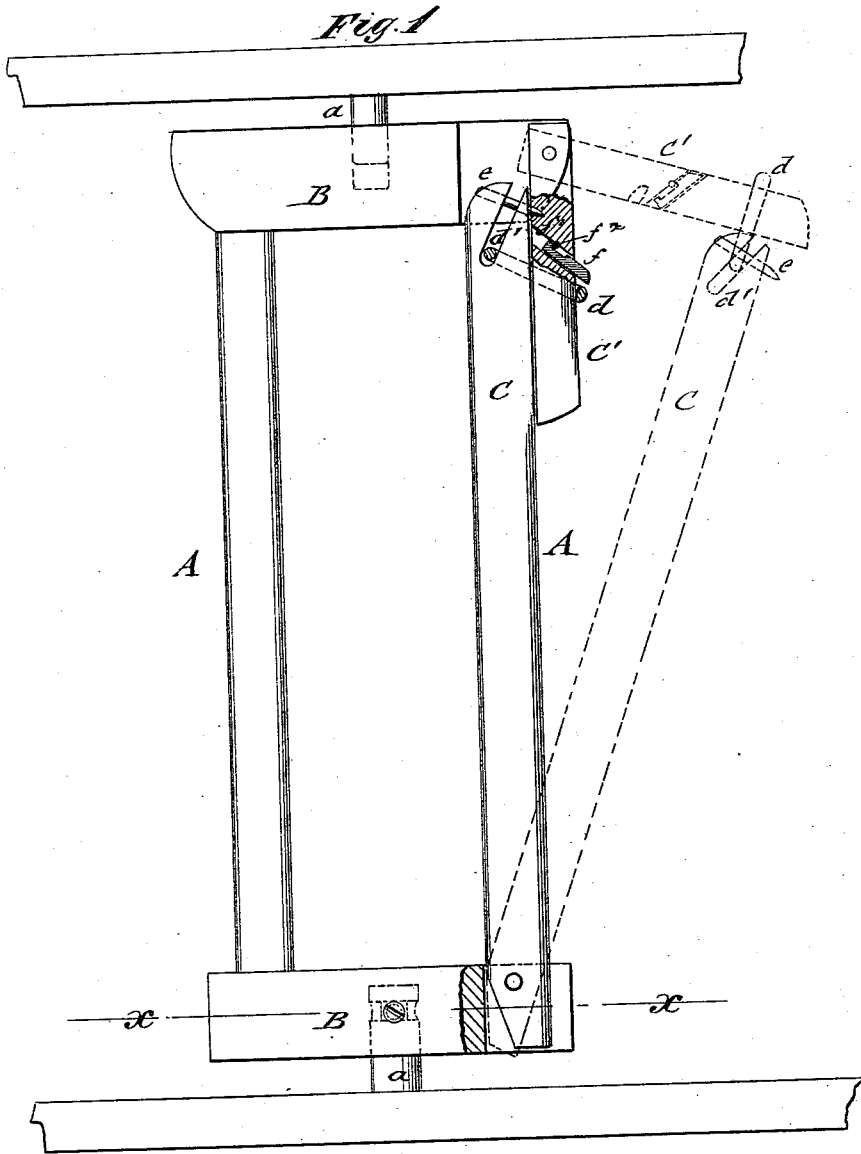

WITNESSES:
A. W. Amqvist
J. H. Scarborough.

INVENTOR:
Z. W. Smith.
BY *[Signature]*
ATTORNEYS.

UNITED STATES PATENT OFFICE.

ZALMON W. SMITH, OF ADDISON, NEW YORK.

IMPROVEMENT IN STANCHIONS.

Specification forming part of Letters Patent No. **192,466**, dated June 26, 1877; application filed April 2, 1877.

To all whom it may concern:

Be it known that I, ZALMON W. SMITH, of Addison, in the county of Steuben and State of New York, have invented a new and useful Improved Stanchion, of which the following is a specification:

In the accompanying drawings, Figure 1 represents a front elevation of my improved stanchion; and Fig. 2, a horizontal section of the same on line *x x*, Fig. 1.

Similar letters of reference indicate corresponding parts.

The invention will first be described in connection with the drawing, and then pointed out in the claims.

In the drawing, A represents a stanchion of suitable height and width, that turns on central top and bottom pivots *a* of a top cross-piece and the flooring, which pivots extend into socket-holes of the top and bottom cross-pieces B of the stanchion. The lower cross-piece B is supported on a lock-iron or set-screw, *b*, which projects into a groove of the lower pivot *a*, which groove is not extended entirely around the circumference of the pivot, as shown in Fig. 2, so as to admit only the turning of the stanchion into suitable inclination to either side, sufficient to admit of free side and up-and-down motion of the head of the cow.

One of the upright side pieces of the stanchion is made of two sections, C C', of which the longer section, C, extends from the lower cross-piece B to the upper one, being pivoted to the recessed end of the lower cross-piece, and retained in the recessed end of the upper cross-piece B by the shorter top section C', that is pivoted to the top cross-piece.

The section C' bears on the outer side of

the longer section C, and is locked thereto by a weighted link, *d*, that moves loosely in a slot, *d'*, at the upper end of section C, being retained by a cross-pin, *e*, in slot *d'*. The link slides readily over the shorter section, C', when placed alongside of the longer section, as shown in Fig. 1, and locks the upper section C' to the longer section C by a latch, *f*, that slides in an inclined slot, *f'*, and is retained so as to project to a certain length by a stop-pin, *f''*.

By sliding the latch back and swinging the link upward the longer section may be swung, in connection with the shorter section, into outward position, as shown in dotted lines in Fig. 1, so as to release the head of the cow by the enlarged space between the sides. For closing the stanchion the longer section C is pushed inwardly, which produces the automatic closing down of the upper section, the dropping of the link, and sliding forward of the latch, so as to produce the automatic and quick locking of the stanchion.

Having thus described my invention, I claim as new and desire to secure by Letters Patent—

1. The combination, with the screw *b*, of the lower stanchion-pivot, provided with circum-jacent arc recess, as and for the purpose described.
2. The combination, with pivoted sections C C', of the weighted link *d*, working in slot *d'*, the latch *f*, sliding in the inclined slot *f'*, and the stop-pin *f''*, as and for the purpose specified.

ZALMON W. SMITH.

Witnesses:

CHAS. W. LEE,
E. D. YOUNG.