

S. GISSINGER.
TOOL-HOLDERS FOR LATHES.

No. 192,499.

Patented June 26, 1877.

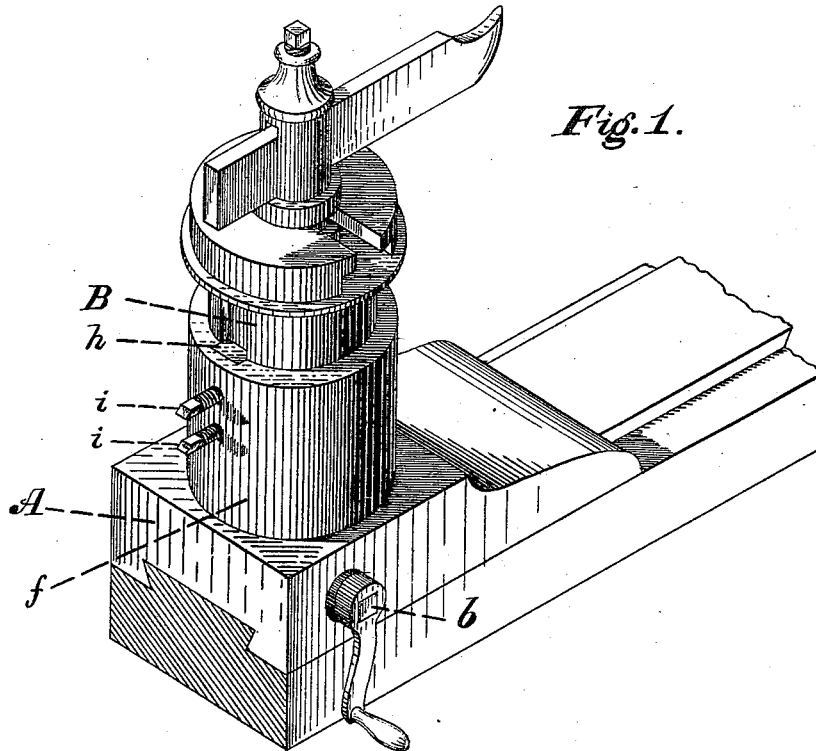

Fig. 1.

Fig. 2.

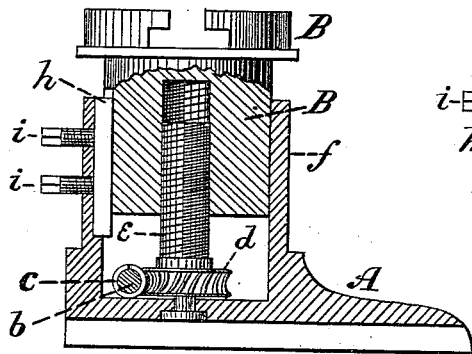
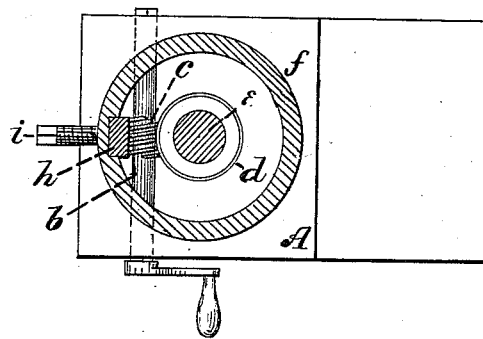

Fig. 3.



Witnesses

J. A. Pollock.

Smith

By

Samuel Gissinger, Inventor

Conolly, Brown & Co.

Attorneys

UNITED STATES PATENT OFFICE.

SAMUEL GISSINGER, OF PITTSBURG, PA., ASSIGNOR OF ONE-HALF HIS
RIGHT TO E. W. SWENTZEL, OF SAME PLACE.

IMPROVEMENT IN TOOL-HOLDERS FOR LATHES.

Specification forming part of Letters Patent No. 192,499, dated June 26, 1877; application filed
November 27, 1876.

To all whom it may concern:

Be it known that I, SAMUEL GISSINGER, of Pittsburg, in the county of Allegheny and State of Pennsylvania, have invented certain new and useful Improvements in Adjustable Tool-Holders for Lathes; and I do hereby declare the following to be a full, clear, and exact description of the invention, such as will enable others skilled in the art to which it pertains to make and use it, reference being had to the accompanying drawings, which form part of this specification, in which—

Figure 1 is a perspective view of my invention. Fig. 2 is a vertical longitudinal middle section. Fig. 3 is a horizontal section.

This invention relates to improvements in tool-post holders for lathes; and consists in the construction and arrangement of parts, substantially as hereinafter described and claimed.

The base A is adapted as usual to the slide by means of the dovetail groove. Passing through the base near the bottom is a shaft, *b*, squared at both ends for a wrench or crank. The shaft *b* has at its middle a worm, *c*, which gears with a spiral-toothed wheel, *d*, stepped in the base, and to which above is centrally fixed a male screw, *e*. Rising around screw *e*, at a little distance, the base A projects upwardly, to form a cylindrical or other shaped socket, *f*, accurately turned or trued inside. The end of the tool-post B is corre-

spondingly shaped and slides up and down therein. In its end vertically is cut a female screw to fit screw *e*. Tool-post B has a groove cut vertically, and socket *f* has a similar groove, so that into the cavity thus formed a key or gib, *h*, may fit, to prevent the post turning in socket *f*. One or more set-screws, *i*, bear through on the key *h*, so as to allow the parts to be tightened up securely.

By turning the worm, by means of a crank or wrench, the wheel *d* is turned, and with it revolves the screw *e*, and the tool-post must rise or fall accordingly; and as it takes several turns of the worm to make one turn of the wheel, it follows that a very accurate setting can be at once obtained, whether the tool is working or at rest.

I claim as my invention—

The combination, with the slide-rest of a turning-lathe, of base A, socketed as set forth, shaft *b*, with its worm *c*, wheel *d*, and screw *e*, and the threaded tool-post B, grooved externally and provided with key *h*, all arranged substantially as described.

In testimony that I claim the foregoing I have hereunto set my hand this 12th day of October, 1876.

SAMUEL GISSINGER.

Witnesses:

B. McKENNA,
E. W. SWENTZEL.