

S. B. RANDALL.

MACHINERY FOR SHAPING AND CREASING LEATHER STRAPS.

No. 192,528.

Patented June 26, 1877.

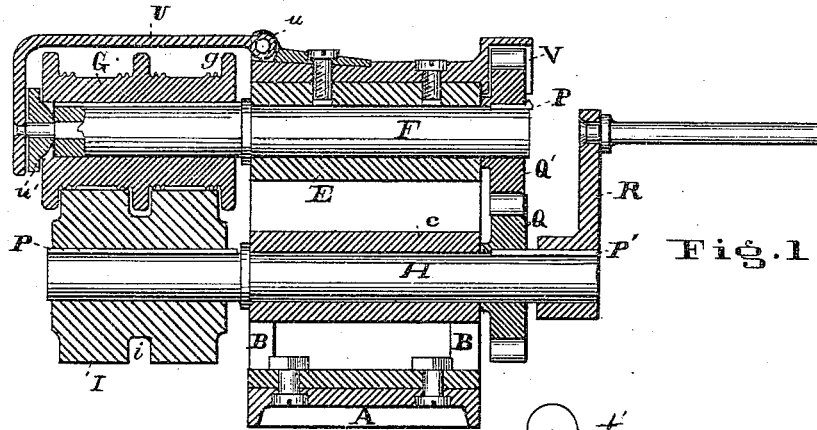

Fig. 1

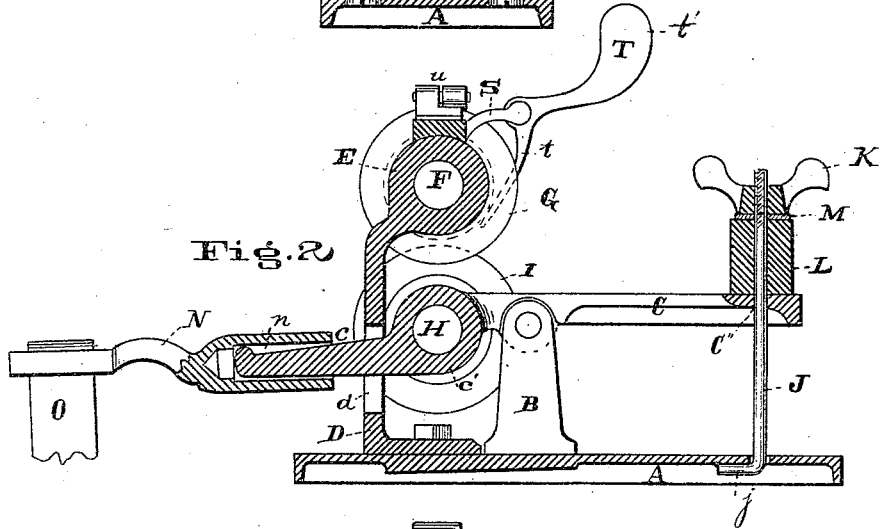

Fig. 2

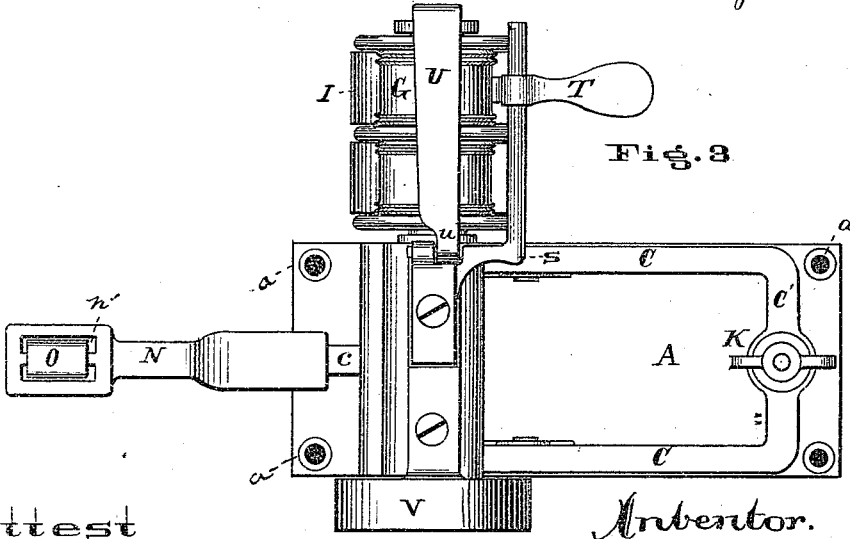

Fig. 3

Attest
Chas. F. Gessert.
Harry E. Saight

Inventor.
Silas B. Randall
By Knight Bros., Atty.

UNITED STATES PATENT OFFICE.

SILAS B. RANDALL, OF CINCINNATI, OHIO.

IMPROVEMENT IN MACHINERY FOR SHAPING AND CREASING LEATHER STRAPS.

Specification forming part of Letters Patent No. 192,528, dated June 26, 1877; application filed May 26, 1877.

To all whom it may concern:

Be it known that I, SILAS B. RANDALL, of Cincinnati, Hamilton county, Ohio, have invented a new and useful Machine for Shaping and Creasing Leather Straps, of which the following is a specification:

My invention relates to certain improvements in those devices for trimming the edges and creasing the faces of leather straps in which the trimming or creasing is effected by rotating cutters or rollers that coact with suitable opposing pressure-rollers on the under side of the strap.

In the accompanying drawings, Figure 1 is an axial section, and Fig. 2 is a transverse section, of a strap-creasing machine embodying my invention. Fig. 3 is a plan of the same.

The operative parts are all external to the frame, which latter consists of a few simple castings, and whose lower member consists of a base, A, having orifices *a*, for the reception of bolts or screws, by which it is secured to the bench.

Extending upward from the base A are two pedestals, B, which constitute the fulcrum-bearings of a forked lever, C.

Bolted to and extending upward from the base A is my "frontal upright" D, having a vertical slot, *d*, for the stem *c* of said forked lever C. My said frontal upright is surmounted by a tubular portion, E, which constitutes the bearing for the shaft F of my upper or creasing roller G.

The lever C has a tubular portion, *c'*, for the shaft H of my supporting or pressure roller I.

The forked rear extremities of lever C unite in a cross-bar, C', having an orifice, *c''*, which receives a rod, J, whose hooked extremity *j* engages under base A, and whose other or upper extremity is screw-threaded for a thumb-nut, K.

A cushion, L, of india-rubber is suitably perforated to envelop rod J, between the cross-bar C' and said nut. A washer, M, is also interposed between the cushion L and the nut.

The stem or forward portion *c* of lever C enters the socket *n* of shank N, which, being slotted, as at *n'*, receives a strap, O, which affords connection with a suitable treadle. (Not here shown.)

In order to secure positive and simultaneous rotation of both rollers, I connect them to their respective shafts by means of feathers P, and at their other extremities to match cog-wheels Q Q', by means of feathers P'.

The feathered extremity of the lower shaft extends sufficiently beyond the cog-wheel for the engagement of a winch, R.

Bolted at *s* to the top of the frontal upright D is a stud, S, which constitutes the bearing of a gravitating-stripper, T, consisting of a finger, *t*, which is caused to press against the periphery of the upper roller by the weighted rear portion *t'*.

My creasing-roller and its corresponding pressure-roller may consist of two or more sections, as shown, for as many different widths of straps, and, when so made, the stripper may be capable of being shifted from one to the other section, as here represented.

In order to retain the creasing-roller securely upon its shaft and yet permit the easy and expeditious removal and substitution of diversely-formed creasing and shaping rolls, I hinge, at *u*, to the top of the slotted upright, an elastic bent arm, U, having a revolving boss or stud, *u'*, that, when said arm is lowered to the position shown, serves to hold the roll to its place upon the shaft, occupying for that purpose one extremity of the axial orifice of said creasing-roll.

An arched flange or canopy, V, projects from the frame D over the cog-wheels, so as to form a guard and screen therefor.

The dimensions of the slot *d* may be such as to limit the upward and downward play of the lever C. By such limitation of the upward play the rollers may be protected from being pressed too closely together.

The creasing-roller has circumferential flanges *g*, which occupy corresponding grooves *i* in the periphery of the supporting-roll I. The flanges *g* serve to keep the straps in place upon the roll, and to slick the edges of the straps.

The creasing-roll is of polished iron or other hard metal, while the supporting-roll may be composed of any hard wood, such as sugar-maple. The framing A B D E is of cast, and the lever C N of malleable, iron. The spring L may be either of india-rubber, as described, or of steel in helical or other suitable

form. The bent arm U is preferably of spring-steel.

For the purpose of operation, the shafts F and H are supplied with the appropriate creasing or trimming rollers and corresponding pressure-rollers, and are secured by the closure of the elastic arm U. The tension of the pressure-roller is regulated by means of the nut K. The operator then grasping the strap to be creased or trimmed, temporarily depresses the pressure-roller by means of the treadle, and inserts the strap between the rollers. He then turns the winch R, causing both rollers to simultaneously revolve, and thus draw through and crease the strap, while the stripper T relieves the finished strap from the roller.

If it is not desired to work the entire length of the strap, the operation may be begun and terminated at any selected parts of the strap by relieving and restoring the roller-pressure by means of the treadle, as above explained.

The operative parts being external to the frame and visible and accessible on every side, any obstruction or defect in either the machine or the material is easily detected and rectified, and the same arrangement of parts affords great facility for changing the rollers from one kind of work to another.

The wide distance which separates the fulcrums B serves to hold the lower roller to perfect parallelism with the upper one in all positions of the lever.

The creasing-roll being stationary, the work passes through without any change of level or distance from the eye, and can, therefore, be watched without inconvenience and regulated with accuracy.

The compression-cushion L being wholly relieved from pressure, when not in actual use, preserves its elasticity for a long time.

I have selected to illustrate my invention a form of machine successfully employed by me; but may vary the parts in non-essential particulars. For example, the pressure-lever

may be a single bar, without the joint at N, and without the aperture between the present forked portions. The machine may be upheld upon an iron or other proper stand of its own, instead of terminating at the base A.

I claim as new and of my invention—

1. The combination of the shaping-roller G, shaft F, slotted standard D E, pressure-roller I, shaft H, fulcrumed support C, and adjustable spring or cushion L, substantially as and for the purposes set forth.

2. The standard D, surmounted by the journal-bearing E of the shaping-roller, and slotted at *d* to accommodate the stem *e* of the lever and journal-bearing C *e'* of the pressure-roller, substantially as and for the purpose set forth.

3. The combination, with the principal roller of a leather-creasing machine, of the gravitating and shiftable stripper T *t'* upon stud S, substantially as and for the purpose set forth.

4. The releasable and elastic arm U, hinged at *u* to the frame D E, and having a revolving boss or stud, *u'*, which occupies a cavity in the outer end of the shaping-roller, as and for the purpose set forth.

5. The forked lever C *e'*, constituting the journal-bearing of the supporting-roll, in combination with the treadle-strap connection O at its front end, and with the adjustable spring or cushion L, nut K, and rod J at its rear end, substantially as and for the purpose set forth.

6. In combination with the pressure-lever C, the separable socket extension N, having slot *n'*, for engagement of treadle-strap O, substantially as set forth.

7. The combination of the standard D E, shaft F, pinion Q, and guard or canopy V, as and for the purpose set forth.

In testimony of which invention I hereunto set my hand.

SILAS B. RANDALL.

Attest:

GEO. H. KNIGHT,
L. H. BOND.