

F. H. SEYMOUR.
DOOR AND DRAWER PLATES.

No. 192,533.

Patented June 26, 1877.

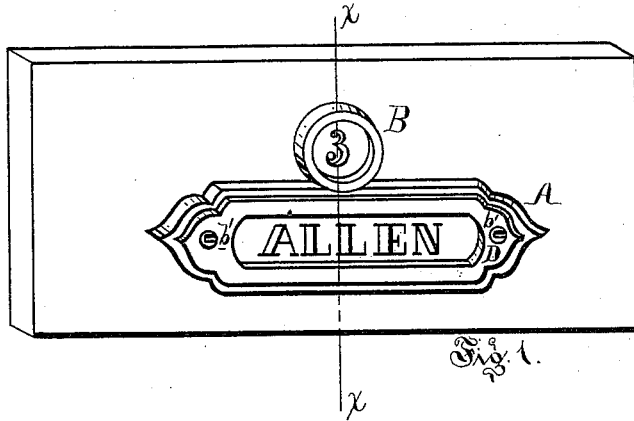

Fig. 1.

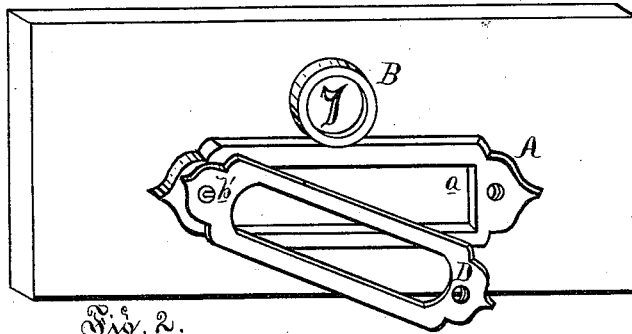

Fig. 2.

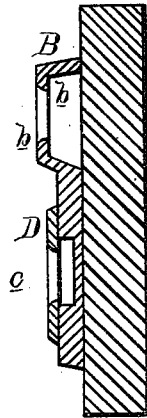

Fig. 3.

Attest:
H. L. Cullis,
Chas. J. Hunt.

Inventor:
F. H. Seymour
By atty
Thos. B. Sprague

UNITED STATES PATENT OFFICE.

FREDERICK H. SEYMOUR, OF DETROIT, MICHIGAN.

IMPROVEMENT IN DOOR AND DRAWER PLATES.

Specification forming part of Letters Patent No. **192,533**, dated June 26, 1877; application filed April 4, 1877.

To all whom it may concern:

Be it known that I, FREDERICK H. SEYMOUR, of Detroit, in the county of Wayne and State of Michigan, have invented a new and useful Improvement in Name and Number Plates; and I do declare that the following is a true and accurate description thereof, reference being had to the accompanying drawings, and to the letters of reference marked thereon, and being a part of this specification.

Figure 1 is a perspective view. Fig. 2 is a perspective view with one end of the frame-plate dropped, and Fig. 3 is a cross-section at *x x*.

The nature of my invention relates to an improvement in the construction of name and number plates, and is especially designed for use upon church-pews; and it consists in an ornamental plate having proper receptacles for the number of the seat and name of the person owning or occupying the same, as is more fully hereinafter set forth.

In the drawing, A represents a metallic plate, having a rectangular depression, *a*, for the reception of the name-card, and it is surmounted by an annular ring, B, having an inwardly-projecting flange, *b*, on its face, in which the desired number is placed. In the depression *a* a card, on which the name is

written or printed, is placed, and to protect its becoming soiled a glass, *c*, is laid over it. These are secured in place by a frame-plate, D, which has a rectangular slot or opening in it corresponding to the size of the depression *a*, and the whole is secured to the door or end of the seat by the screws *b'* passing through both plates. Before securing the plate to its place the number of the seat may be placed in the ring B, it being held in position by the flange *b*.

If desired, a porcelain knob, bearing the proper number upon its convex face, may be secured within the ring instead of the number upon card, as that portion of the plate is designed to be permanent.

When it is desired to change the name, it is only necessary to remove one of the screws *b'* and let the plate D drop, as seen in Fig. 2; the name can then be removed and another substituted therefor.

What I claim as my invention is—

The name and number plate described, consisting of the plate A, the ring B, and the frame-plate D, constructed and arranged substantially as set forth and shown.

FREDERICK H. SEYMOUR.

Witnesses:

H. S. SPRAGUE,
H. F. EBERTS.