

G. W. BAKER.
PHOTOGRAPHIC EYE-REST APPARATUS.

No. 192,854.

Patented July 10, 1877.

Fig 1

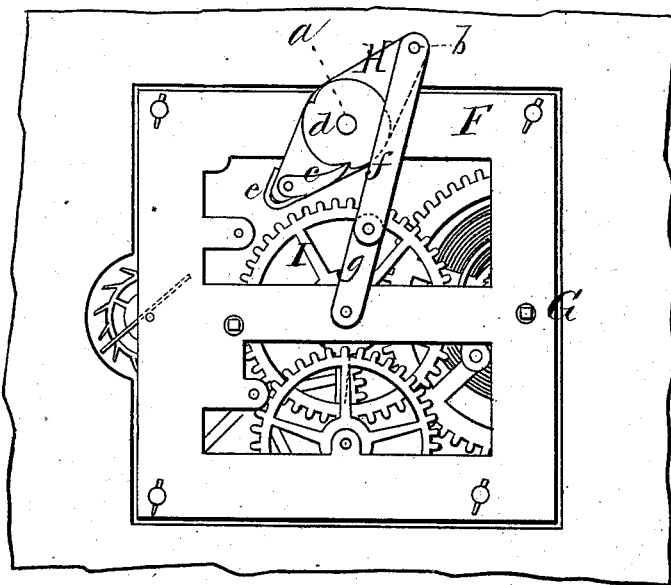
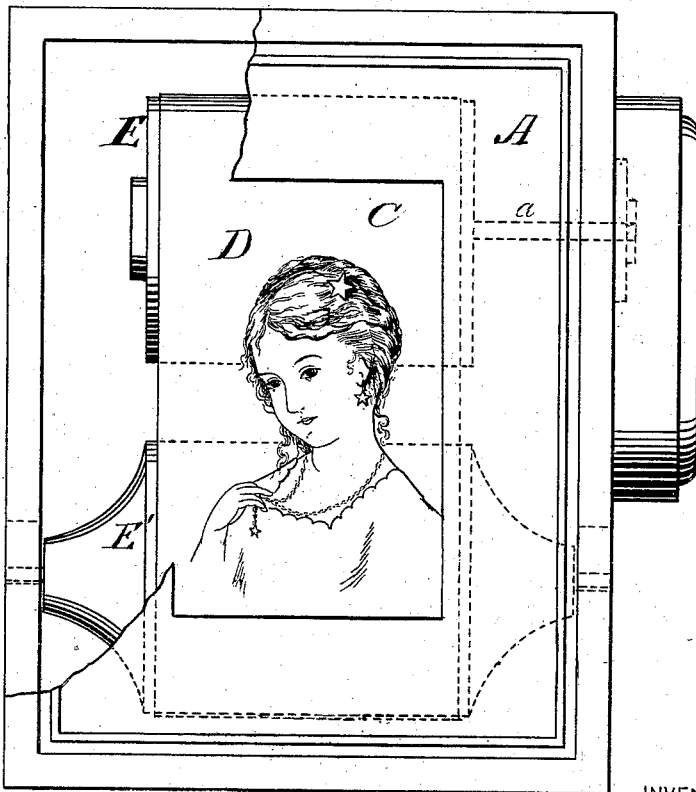

Fig 2



WITNESSES
Villette Anderson.
F. J. Massie

INVENTOR
George W. Baker,
by E. W. Anderson
 ATTORNEY

G. W. BAKER.
PHOTOGRAPHIC EYE-REST APPARATUS.

No. 192,854.

Patented July 10 1877.

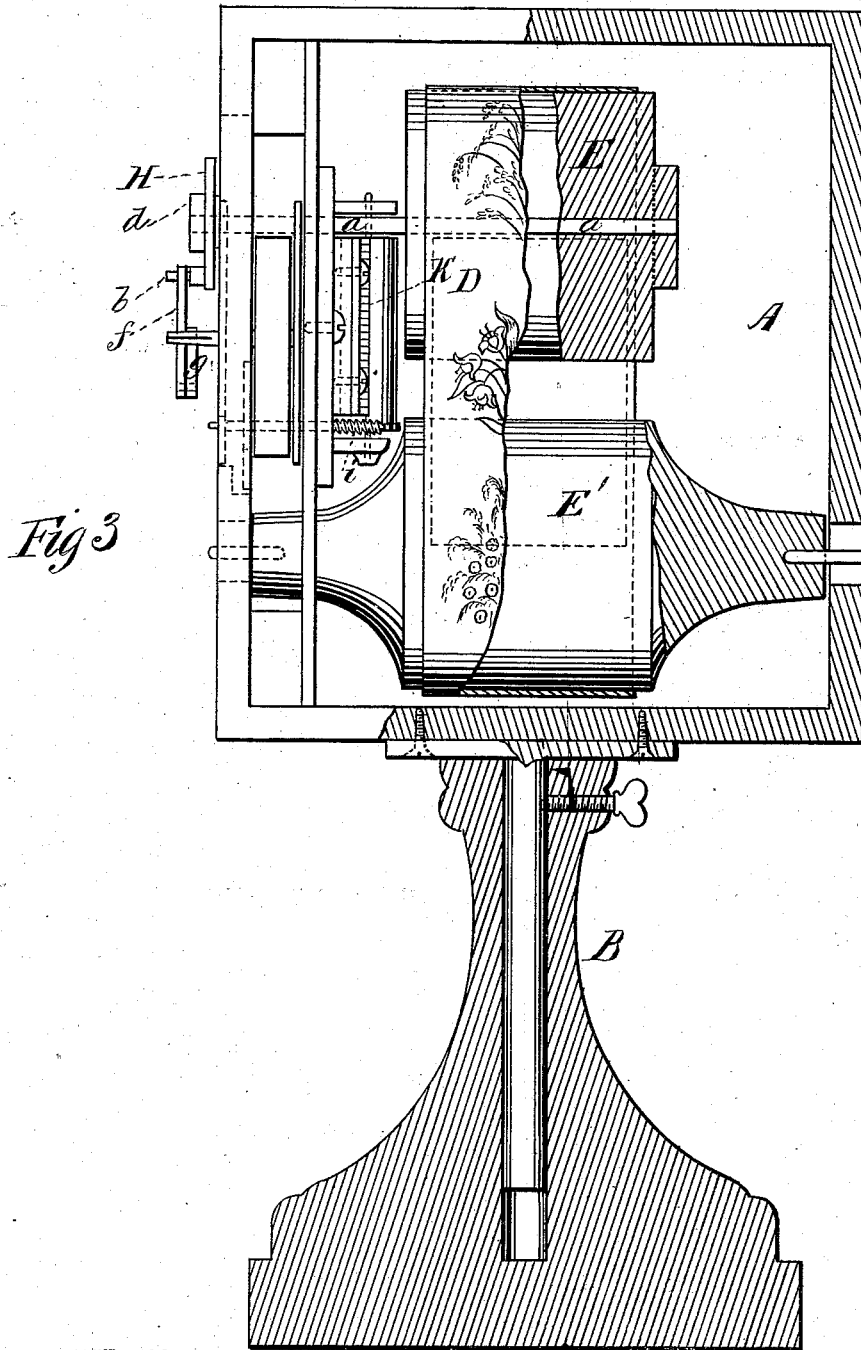

Fig 3

WITNESSES
Villette Anderson.
F. J. Clavin

INVENTOR
George W. Baker,
by E. W. Anderson,
ATTORNEY

UNITED STATES PATENT OFFICE

GEORGE W. BAKER, OF WILMINGTON, DELAWARE.

IMPROVEMENT IN PHOTOGRAPHIC EYE-REST APPARATUS.

Specification forming part of Letters Patent No. 192,854, dated July 10, 1877; application filed June 17, 1876.

To all whom it may concern:

Be it known that I, GEO. W. BAKER, of Wilmington, in the county of New Castle and State of Delaware, have invented a new and valuable Improvement in Photographers' Apparatus; and I do hereby declare that the following is a full, clear, and exact description of the construction and operation of the same, reference being had to the annexed drawings, making a part of this specification, and to the letters and figures of reference marked thereon.

Figure 1 of the drawings is a representation of a side view of my improved eye-rest apparatus, showing the mechanism for giving intermittent motion to the belt. Fig. 2 is a front view of the case of the apparatus, with a figure in sight through the show-opening; and Fig. 3 is a partial vertical section of the same.

This invention has for its object to produce a device in the nature of an eye-rest, which shall pleasantly fix the attention of sitters during the operation of taking photographic pictures, and thus relieve nervous persons of a considerable trial; and it consists in an endless belt, provided upon one of its faces with attractive pictures, which are successively brought, and temporarily detained, in front of a show-opening in a box by the intermittent rotation of suitable rollers arranged therein. It also consists in certain novel means whereby continuous rotation is imparted to the barrel of a musical box attachment, and an intermittent rotation to the rollers carrying the panoramic belt, as will be hereinafter more fully set forth.

In the annexed drawings, the letter A designates a preferably rectangular box or case, which, for convenience of handling, will be mounted on a stand, B. Casing A is provided with a show-opening, C, through which will be successively exhibited a series of attractive pictures, painted, printed, or otherwise applied to the outer surface of a flexible endless belt, D, passing over two rollers, E E', arranged the one above the other in casing A. Roller E' has its bearings in the lower part of the sides of the box, but the shaft of roller E will be mounted in the upper portion of the

frame F of a clock-work mechanism, G. This shaft, designated by the letter *a*, extends entirely through the frame, and is provided on its projecting end with a vertically-vibrating beam or pawl-carrier, H. This carrier is applied loosely upon shaft *a*, and vibrates independently thereon. As shown in Fig. 1, it is provided at one end with a wrist-pin, *b*, and at the other with a pawl, *c*, actuated by a spring, *e*, to engage automatically with a ratchet-disk, *d*, rigidly secured upon the end of shaft *a*, outside of the pawl-carrier. A rocking or oscillating movement is applied to the pawl-carrier H by means of a pitman, *f*, connected in the usual manner to the said carrier and to a crank-arm, *g*, keyed upon the projecting end of the shaft of a gear-wheel, I, through which motion is communicated from the spring-actuated master-wheel to the remainder of the mechanism.

When the spring is wound up its reaction will impart the oscillating movement above mentioned to the walking-beam, with the effect of causing the pawl to engage with and disengage from the ratchet-disk *d*, and thus giving an intermittent motion to roller E. By this means a corresponding movement will be given to the panoramic belt, and as each picture is brought before the show-opening it will remain quiescent a sufficient time to allow of its being inspected, when it will be moved away and another will present itself.

In order to secure absolute certainty in the movements of the belt the roller E will be provided with spurs, which will be received in perforations in the said belt, and insure its action. Gear I, above mentioned, actuates a shaft having on its end a worm, *i*, actuating a gear-wheel applied to the end of the barrel J of a musical-box attachment. This barrel is provided with the usual spurs, which, coming in contact with a comb-like steel sounder, K, will, during the operation of the decoy, produce the additional attraction of music.

To nervous persons having their pictures taken it will be a great relief to disconnect their thoughts from the paramount necessity of keeping still, and by examining the pictures as they are exhibited to while away the time of such enforced stillness. It will also be of

great avail in taking the pictures of restless children to distract their minds by the sight of the pictures and the sound of the music.

In lieu of the endless belt and its rollers I may substitute a single shaft, provided with radial arms, upon the free ends of which the pictures or views may be secured without materially altering the nature of my invention; or the pictures may be supported by vertical rods arranged at a suitable distance apart around a horizontally-rotating disk or plate.

The pictures or views may be of any description—that is, landscapes, portraits, the representations of animals, and the like, and I prefer to have them detachable, so that other pictures or views may be substituted therefor when desirable.

What I claim as new, and desire to secure by Letters Patent, is—

1. The photographers' eye-rest apparatus herein described, consisting of the musical-box

attachment, the endless panoramic belt, and the intermittently-rotating rollers carrying the said belt, arranged inside of a casing having a show-opening, substantially as specified.

2. In combination with the casing A, having a show-opening, C, the endless panoramic belt D, and the intermittently-rotating rollers E E', substantially as specified.

3. The roller-shaft *a*, the carrier or beam H, rocking independently thereon, a ratchet-disk, *d*, connected to the shaft *a*, pawl *c*, and a wrist-pin, *b*, in combination with the clock mechanism G, the crank-arm *g*, and pitman *f*, substantially as specified.

In testimony that I claim the above I have hereunto subscribed my name in the presence of two witnesses.

GEO. W. BAKER.

Witnesses:

JNO. HENRY PUHL,
A. P. BEECHER.