

W. E. CANEDY & F. LARSON.  
 PORTABLE-FORGE.

No. 192,975.

Patented July 10, 1877.

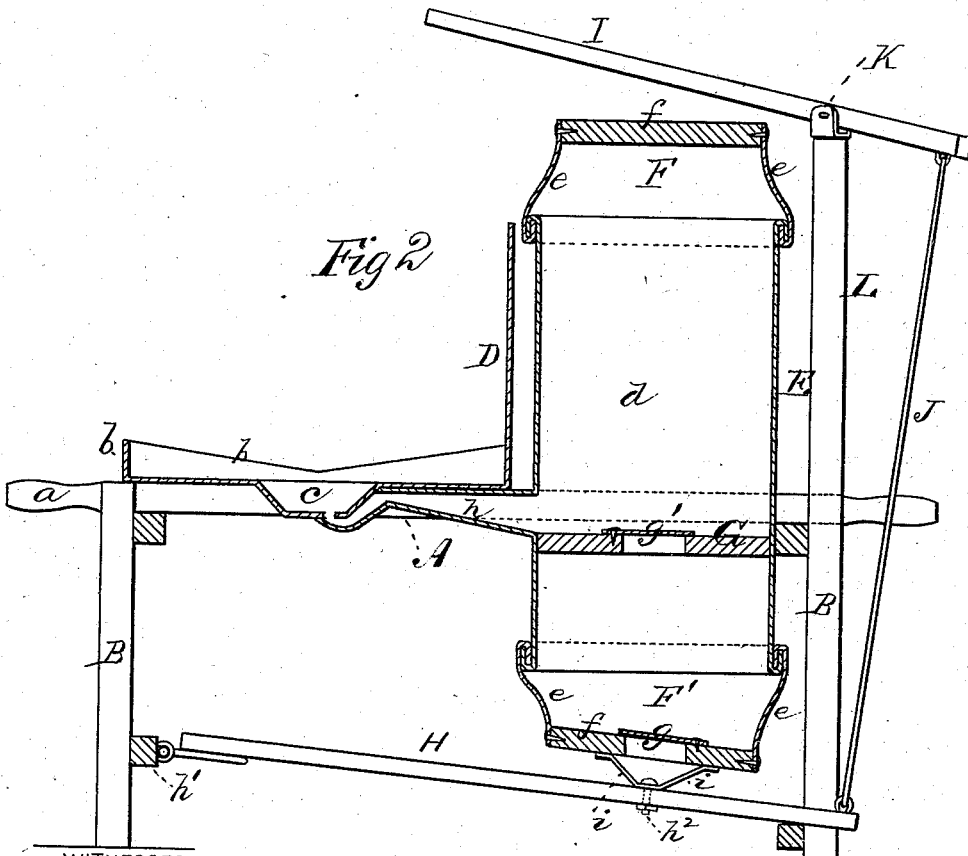
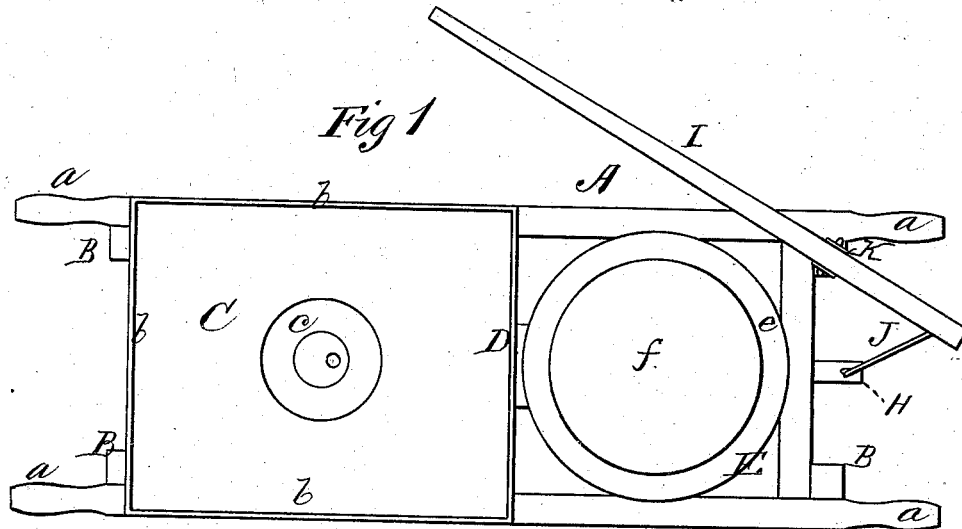

WITNESSES  
*M. S. Utley.*  
*C. J. Chase*

INVENTORS  
*Wm. E. Canedy.*  
*Frank Larson.*  
 by *E. W. Anderson.*  
 ATTORNEY

# UNITED STATES PATENT OFFICE.

WILLIAM E. CANEDY AND FRANK LARSON, OF ROCHESTER, MINNESOTA.

## IMPROVEMENT IN PORTABLE FORGES.

Specification forming part of Letters Patent No. 192,975, dated July 10, 1877; application filed April 21, 1877.

### *To all whom it may concern:*

Be it known that we, WILLIAM E. CANEDY and FRANK LARSON, of Rochester, in the county of Olmsted and State of Minnesota, have invented a new and valuable Improvement in Portable Forges; and we do hereby declare that the following is a full, clear, and exact description of the construction and operation of the same, reference being had to the annexed drawings, making a part of this specification, and to the letters and figures of reference marked thereon.

Figure 1 of the drawings is a representation of a top view, and Fig. 2 a longitudinal central section, of our improved forge.

This invention has relation to improvements in portable forges; and it consists in a bellows composed of an upright cylindrical body having at each end a flexible cap forming airtight joints therewith, and a rigid head in each cap, which cylinder is divided into two chambers by a valved diaphragm, and is connected with the fire-place by a tube opening at one end in said cylinder, and at the other into the fire-place of the forge, above said diaphragm, and, in connection therewith, of a vibrating lever operating the lower cap, and connected with the vertically and horizontally vibrating lever, that is arranged above and operates at each descent the upper cap, as hereinafter described and claimed.

In the annexed drawings, the letter A designates a rectangular wooden frame, that is supported in a horizontal position by braced legs B, and whose side rails are provided at each end with handles *a*, by means of which the frame and the forge supported thereon may be readily transported from place to place. C represents a sheet-metal plate, having at its center or thereabout a depression, *c*, in which the coals used in heating metals for forging or tempering purposes will be deposited, and at each side and at one end farthest from the bellows E, a ledge, *b*, serving to prevent waste of coal.

At the end next the bellows is a vertical metallic guard, D, that may be formed in one piece with the hearth C, that serves to protect the fire from adverse drafts, and prevent the coals from falling off the hearth aforesaid, at this end.

At the rear of the guard D is located the bellows E. This is composed of a preferably cylindrical metallic body, *d*, extending above and below the frame A, so as to lower its center of gravity between its side rails, and of two heads, F F', respectively at its upper and lower ends, composed each of a conical leather or other air-proof part, *e*, and a wooden or other head, *f*, of less diameter than the cylinder aforesaid. The lower head, *f*, is provided with a valve, *g*, opening upward, and a like valve, *g'*, is placed in a diaphragm, G, arranged in the cylinder at or near its middle. The body *d* above the diaphragm is connected with the depression *c* at its bottom by a pipe, *h*, decreasing in diameter from the body to the depression, so as to concentrate and intensify the blast.

H represents a vertically-vibrating lever, that is pivoted at one end to a brace, *h'*, of the frame, and extends below the bellows from end to end of the same. This lever is connected, by means of a bolt, *h''*, with a metallic plate, *i*, that bridges the valve opening in the lower head, *f*, and is actuated through the medium of a connecting-rod, J, by a lever, I. This is fulcrumed in an arm, K, having its bearings on the upper end of an upright, L, of the frame, and vibrating horizontally thereon, so that the said lever has both horizontal and vertical movement. It is thrown across the upper head, *f*, of the bellows, and actuated in the usual manner. At each upward movement thereof the lever H will be depressed, admitting air into the bellows, that, at the downward stroke of the same, will be forced upward into the upper part of said bellows through valve *g'* of the diaphragm. At the same time both the flexible heads will be compressed, and the air both above and below said diaphragm forced through the tapering nozzle into the hearth or fire-place in a very strong current.

What we claim as new, and desire to secure by Letters Patent, is—

1. The combination, with the bellows E, having a cylindrical body portion, *d*, valved diaphragm G, and the upper flexible cap F, and the lower flexible cap F', of the lever H, connecting-rod J, the vertically and horizontally vibrating lever I, arranged over and op-

erating to depress at each descent the upper flexible cap F, the conduit h, and the hearth of the forge, substantially as specified.

2. The bellows having a rigid center and flexible caps at each end of said central portion, and the vertically-vibrating levers H I, the latter arranged over and operating to depress at each descent the upper flexible cap, connected by a rod, J, combined substantially as specified.

In testimony that we claim the above we have hereunto subscribed our names in the presence of two witnesses.

WILLIAM E. CANEDY.  
FRANK LARSON.

Witnesses:

NED GEORGE,  
JAMES GEORGE.