

H. B. HAYES.  
WATER-METER.

No. 192,990.

Patented July 10, 1877.

Fig. 1.

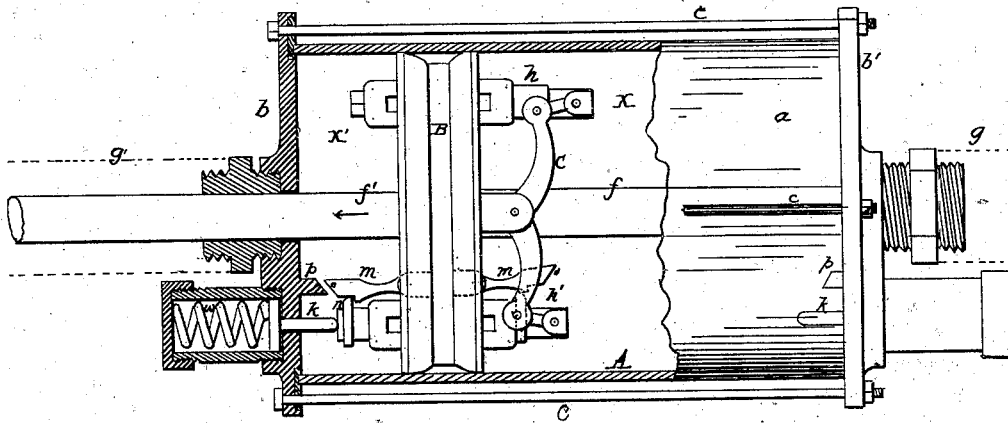
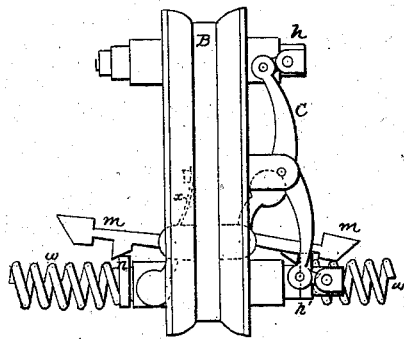

Fig. 2.



Attest:

*Fred Benjamin*  
*Howard Gurly*

*H. B. Hayes*  
*By his attorney*  
*Charles V. Foster*

# UNITED STATES PATENT OFFICE.

HENRY B. HAYES, OF WOBURN, MASSACHUSETTS.

## IMPROVEMENT IN WATER-METERS.

Specification forming part of Letters Patent No. 192,990, dated July 10, 1877; application filed June 21, 1877.

*To all whom it may concern:*

Be it known that I, HENRY B. HAYES, of Woburn, Middlesex county, Massachusetts, have invented certain Improvements in Water-Meters, of which the following is the specification:

My invention relates to improvements in that class of meters, &c., in which a piston reciprocating in a cylinder is provided with a hollow piston-rod, and with passages and valves, arranged to automatically admit and discharge the fluid from opposite sides of the piston; and my invention consists in constructing the valves and their appliances so as to insure their quick and positive adjustment at each end of the stroke, independently of the movement of the piston.

In the drawings, Figure 1 is a longitudinal section of sufficient of a water-meter to illustrate my invention. Fig. 2 is a modification.

A is the cylinder, consisting of the glass body *a*, (to which no claim is here made, as it will constitute a separate application for Letters Patent,) and the heads *b b'* tied together and to the body by bolts *c c*.

The piston B carries a suitable packing, so as to reciprocate with but little friction, and is provided with two passages, one communicating with one end, *f*, of a hollow piston-rod, and the other with the other end, *f'*, of said rod, which slides through suitable packing-boxes at the ends of the cylinder, and within the inlet-pipe *g* and outlet-pipe *g'*.

The piston is provided with two valves or sets of double valves, *h h'*, each having two heads adapted to seats on opposite sides of the piston, and constructed so as to open or close the communication between the passages and the chambers X X' on opposite sides of the piston.

The two sets of valve-shafts are connected by a rock-lever, C, or other suitable mechanism, so as to insure a simultaneous, but reverse, movement of the two valves.

Water from the water-pipe *g* flows into the end *f* of the piston, and through one passage into the chamber X, moving the piston in the direction of the arrow until the positions of the valves are reversed, when the water from the other passage will flow into the chamber X' reversing the motion of the piston, the

water in the chamber X then passing through the first-mentioned channel in the piston into the end *f'* of the piston-rod and to the outlet.

The construction of the piston-head and arrangement of the valves to open and close the passages, as specified, form no part of this invention, as they are the subject of a prior application for Letters Patent. While the movements above described insure a reciprocation of the piston, and a consequent measurement of the water, the quantity of which is registered by any suitable mechanism, it has been found exceedingly difficult to operate the valves so as to insure the desired effect.

When the water flows rapidly through the meter under a high pressure, the momentum of the piston is of itself sufficient to bring the valve-shafts against the ends of the cylinder and reverse the valves. But I have found that such an arrangement is not practical in an operative meter, as under many circumstances the water flows very slowly or the pressure is but nominal. Under such conditions the piston will be moved forward until the valves are partly open when the counter-currents thus admitted at once to both sides of the piston instantly stop its motion.

My improvement consists in the application of a power generated by the movement of the piston, but independent of the latter, to reverse or adjust the valves, thus rendering their action certain, whether the piston travels rapidly or slowly, with much or little force.

One mode of carrying out the invention consists in the use of springs *w*, which are compressed by the piston as it moves, and are automatically released, as the piston reaches the end of its motion, and by their power reverse or adjust the valves.

The position of the springs is not material. In Fig. 1 they are combined with rods *k*, sliding through the piston-heads, and arranged to be struck by the valve-stems, and the latter are prevented from yielding to the spring-pressure by latches *m*, which catch on collars *n* on the stems, and have inclined ends *o*. Inclined studs *p* on the piston-heads, serve as bearings for the ends of the latches, when the piston reaches the end of its stroke, and

by elevating the latches release the valve-stems, which are then suddenly and forcibly thrown inward, reversing the valves and the motion of the piston.

It will be apparent that this effect is produced regardless of the speed or force with which the piston moves, and it has been found that any head of water sufficient to overcome friction, and the force of the spring, and any movement of the piston, however slow, are sufficient to insure a continuous operation of the meter.

When arranged as shown in Fig. 1, the latches will fall into place by their gravity, but springs *x* may be used to insure the movement when the parts are reversed or the cylinder is vertical.

In place of springs the latches may constitute each an arm of a bell-crank lever, the other arm being weighted, as shown in Fig. 2, which also illustrates a modification, in which the spring is carried by the valve-shaft, thus avoiding the friction of the sliding rod *k*.

The latch catching on the collar or shoulder of the valve-spindle prevents its movement while the spring is compressed between the piston and head of the cylinder, but releases the spindle as soon as it is raised by contact with the inclined lug.

Instead of a spiral spring a bow or rubber spring, or a body of air confined by a piston to be compressed on the movement of the meter-piston may be used, or a weight may be raised, or any other arrangement may be adopted, whereby the motion of the piston is caused to accumulate power to be afterward employed in throwing the valves.

It will be apparent that the apparatus described may be used with advantage in transmitting water or air power, and for small engines, as well as for measuring purposes.

Without limiting myself to the construction and arrangement of parts shown,

I claim—

1. The mode of operating the valves of a reciprocating piston by power generated from the traveling piston, and stored, and suddenly and automatically released by the movement of the piston, as specified.

2. The combination, with the valves carried by the piston reciprocating in a cylinder, of a spring or its equivalent, in which power is stored by the movement of the piston and devices for suddenly releasing the spring and transmitting the power to the valves, substantially as set forth.

3. The combination of the piston, its valves, and latches for holding the same, devices for operating said latches and releasing the valves at the ends of the stroke, and springs, weights, or equivalent devices, in which power is accumulated by the movement of the piston, arranged to operate the valves when released, as specified.

In testimony whereof I have signed my name to this specification in the presence of two subscribing witnesses.

H. B. HAYES.

Witnesses:

J. H. ADAMS,  
L. H. LATIMER.