

D. LINDSAY.
FEATHERING PADDLE-WHEELS.

No. 193,008.

Patented July 10, 1877.

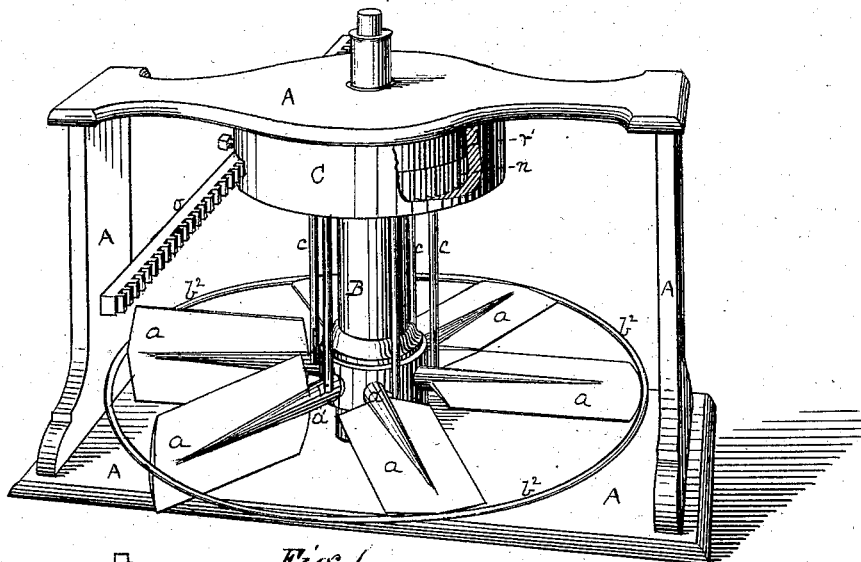

Fig. 1.

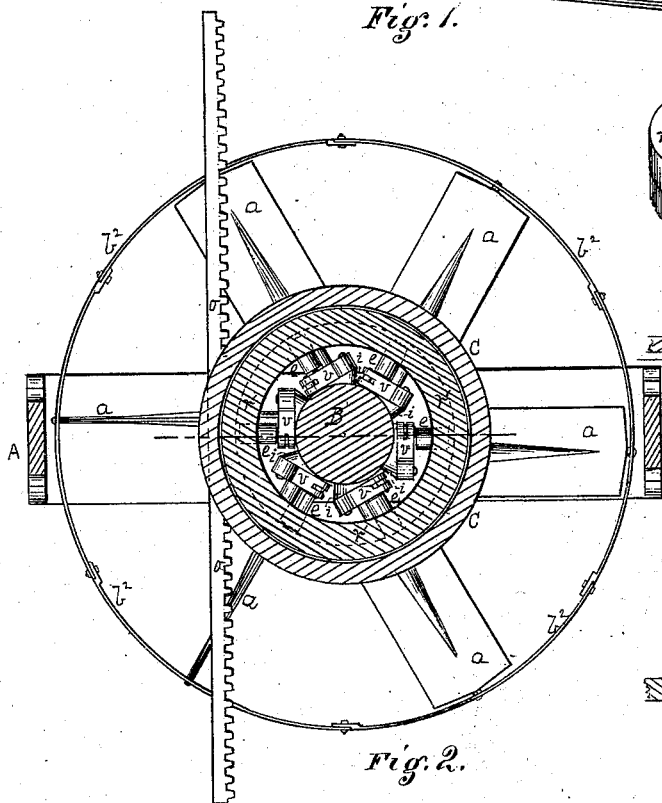

Fig. 2.

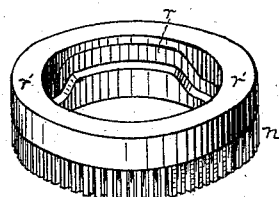

Fig. 4.

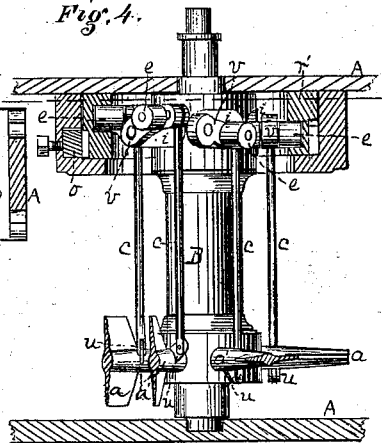

Fig. 3.

Witnesses
P. C. Christy
O. L. Parker

Inventor David Lindsay,
By *Attorney* George H. Christy

D. LINDSAY.
FEATHERING PADDLE-WHEELS.

No. 193,008.

Patented July 10, 1877.

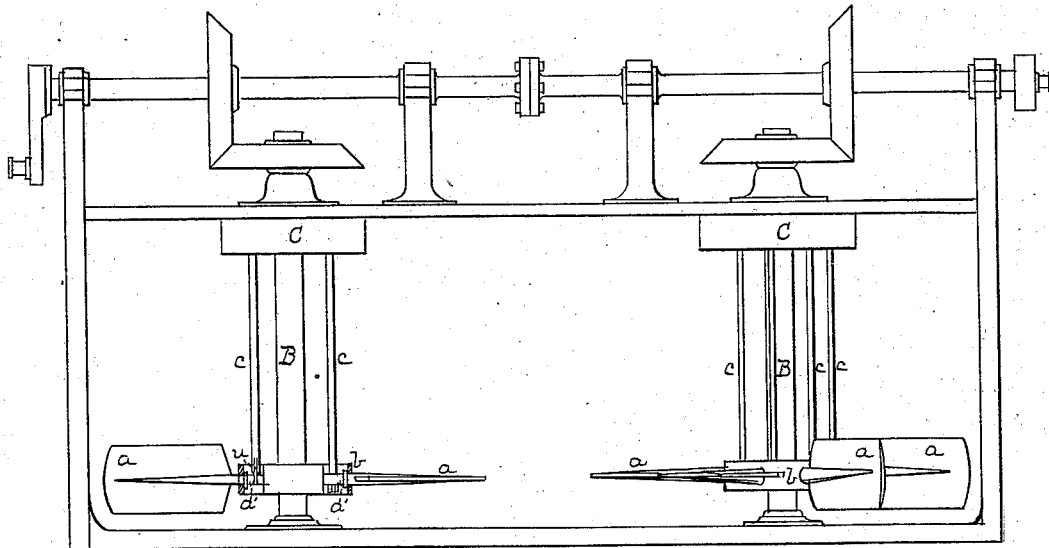

Fig. 5.

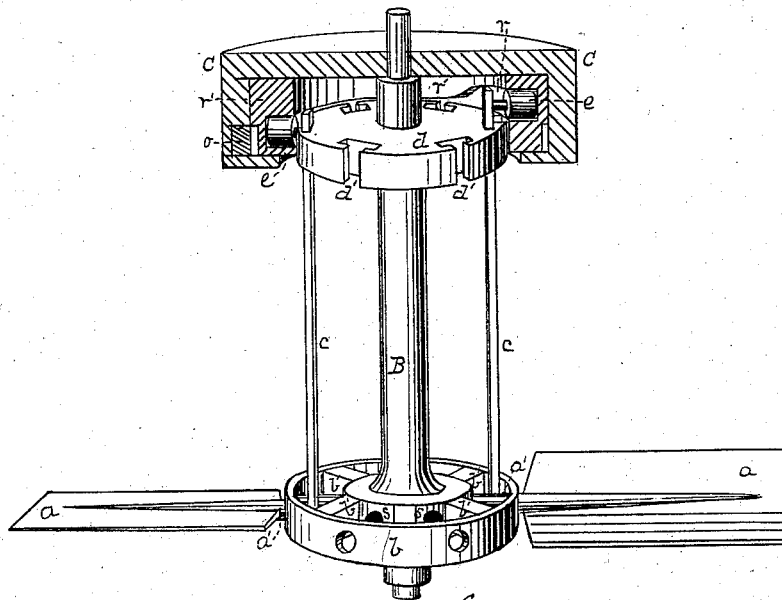

Fig. 6.

Witnesses
G. C. Christy
O. Parker

Inventor David Lindsay,
By *Attorney* George H. Christy.

UNITED STATES PATENT OFFICE.

DAVID LINDSAY, OF PITTSBURG, PENNSYLVANIA.

IMPROVEMENT IN FEATHERING PADDLE-WHEELS.

Specification forming part of Letters Patent No. 193,008, dated July 10, 1877; application filed June 12, 1877.

To all whom it may concern:

Be it known that I, DAVID LINDSAY, of Pittsburg, county of Allegheny, State of Pennsylvania, have invented or discovered a new and useful Improvement in Feathering Paddle-Wheels; and I do hereby declare the following to be a full, clear, concise, and exact description thereof, reference being had to the accompanying drawing, making a part of this specification, in which—like letters indicating like parts—

Figure 1 is a perspective view of my improved feathering paddle-wheel, with part of the case broken away. Fig. 2 is a top-plan view of the same, the cap of the frame-work being removed. Fig. 3 is a detached view, showing in sectional elevation a part of the apparatus for feathering the paddles. Fig. 4 is a perspective view of the cam-ring, which gives motion to such apparatus. Fig. 5 shows, in outline, one method of adapting my improved wheel to the stern of an ordinary river-boat; and Fig. 6 is a detached perspective, partly in section, showing certain modifications in the apparatus.

My invention relates to that class of paddle or propelling water-wheels known as "feathering-wheels," wherein each blade or paddle is made to present its face transverse to the line of motion during some certain part of its revolution, or while such position would assist in propulsion, and during the balance of its revolution the face of the blade is turned so as to be in the plane of its revolution, and thus offer a minimum of resistance.

My improved wheel is intended to operate under water—that is, the whole of the wheel proper being submerged; and, as hereinafter described, it may be used both for propelling and steering.

A, Fig. 1, represents any suitable frame-work, in which is mounted an upright shaft, B, in such manner as to be free to rotate or turn in suitable bearings on the frame-work, and also to have sufficient strength for supporting and carrying the paddles. The lower end of the shaft B has an enlarged head, in which are holes *s*, Fig. 6, corresponding to the position and number of the paddles employed.

Each paddle consists of a blade, *a*, and shaft *a'*, and, by preference, I support them in posi-

tion by passing the shaft *a'* through suitable holes in the ring *b*, Fig. 6, and seating the end in the holes *s* in the upright shaft B, thus giving two bearings to each paddle, and making it free to turn in such bearings.

The paddles may be secured in place by means of a sleeve clamped to the shaft of each between the bearings, or in any convenient way.

The ring *b* is securely attached to the shaft B by means of arms *b¹*. An additional ring, *b²*, may, if desired, be placed outside the blades of the paddles, and the blades pivoted thereto, as shown in Figs. 1 and 2. I prefer to make such ring, when employed, in sections, as shown in Fig. 2, so that any paddle may be removed without removing or disturbing others. This ring *b²* may also be supported by arms extending from it to the shaft B.

In order to feather the blades of the paddles, or turn them from a vertical to a horizontal position, and vice versa, I make use of bars or rods *c*, which are pivoted at their lower ends to cranks or lugs *u* on one side of the shafts of the paddles, and at their upper ends they connect with wrists or rollers *e*, which work in a cam-groove, *r*, Fig. 4. The connection between the rods *c* and wrists *e* may either be direct, as shown in Fig. 6, or may be made through the medium of levers or cranks, as shown in Fig. 3. I prefer the direct connection both for simplicity and compactness of construction.

As shown in Fig. 6, a collar, *d*, is secured to the shaft B, having guide slots or recesses *d'* in its periphery for receiving and guiding the bars *c*. As there shown, this collar *d* is placed nearly opposite the cam-ring *r'*. In the form of connection shown in Fig. 3, flat-ended lugs *i* are formed on the periphery of the shaft B, opposite the cam-ring *r'*. Levers or cranks *v* are pivoted at one end to these lugs, one on each, the other ends of the cranks being pivoted to or connected with the rods *c*. Wrists *e* are attached to these crank-levers *v*, which operate in the cam-groove *r* substantially as when the direct attachment is made, as described, and shown in Fig. 6.

The ring *r'*, in which is the cam-groove *r*, is inclosed in the case or box C, which, in turn, is securely fixed to the frame-work. The ring

is thus supported independent of the shaft B and the devices which the shaft carries. Thus, while the shaft is rotated by the driving machinery, the ring may remain stationary, or may be moved, as hereinafter described, independent of the shaft.

The cam-groove r in the ring r' is so made as to give the wrists e a vertically-reciprocating movement as they move around the groove, and this vertical movement is sufficient to give to the paddles, through the rods c , a quarter-turn, and so give the blades, alternately, a horizontal and vertical position. The groove is also so shaped, by preference, that two paddles, at least, may at all times operate to propel a boat. This is accomplished by making the cams in the groove of proper length of throw.

While the ring r' remains in any given position, the paddles will be made to work—that is, will be changed from a horizontal to a vertical position—at a certain part of their revolution corresponding to the cam in the ring. If the ring be turned in its case so as to change the position of the cam, the working-point of the paddles will be correspondingly changed, and so the line or direction of power exerted thereby will be changed. The ring may be turned in its case for this purpose by any convenient mechanism. The device which I have shown, and which I now believe to be the best, is a pinion or geared rim, n , attached to the ring r' , and a rack-bar, o , sliding in suitable

bearings in the case C, gears into the pinion, so that, by moving the rack back and forth, the ring may be turned, as desired. By properly connecting a tiller-rope to the rack-bar, the described mechanism will be under the control of the pilot, and may be operated by him to steer the boat, as well as propel the same, in any desired direction.

I have shown in outline, Fig. 5, two of my improved wheels geared to the crank-shaft of a stern-wheel boat. Other forms of adaptation may be made, however, varying with the different conditions involved, and such changes in adaptation will be readily made by the skilled mechanic.

I claim herein as my invention—

1. In a feathering paddle-wheel, the combination of shaft B, a series of continuously-rotating paddles pivoted thereon, rods c , wrists e , and cam r , substantially as set forth.

2. The combination of adjustable ring r' , having a cam-groove, r , therein, wrists e , rods c , paddles a , and shaft B, substantially as described.

3. The combination of rack-bar o , geared cam-ring r' , wrists e , rods c , paddles a , and shaft B, substantially as set forth.

In testimony whereof I have hereunto set my hand.

DAVID LINDSAY.

Witnesses:

JNO. A. MELSON,
CLAUDIUS L. PARKER.