

H. O'NEILL.

MACHINES FOR PUNCHING AND SHEARING METAL.

No. 193,026.

Patented July 10, 1877.

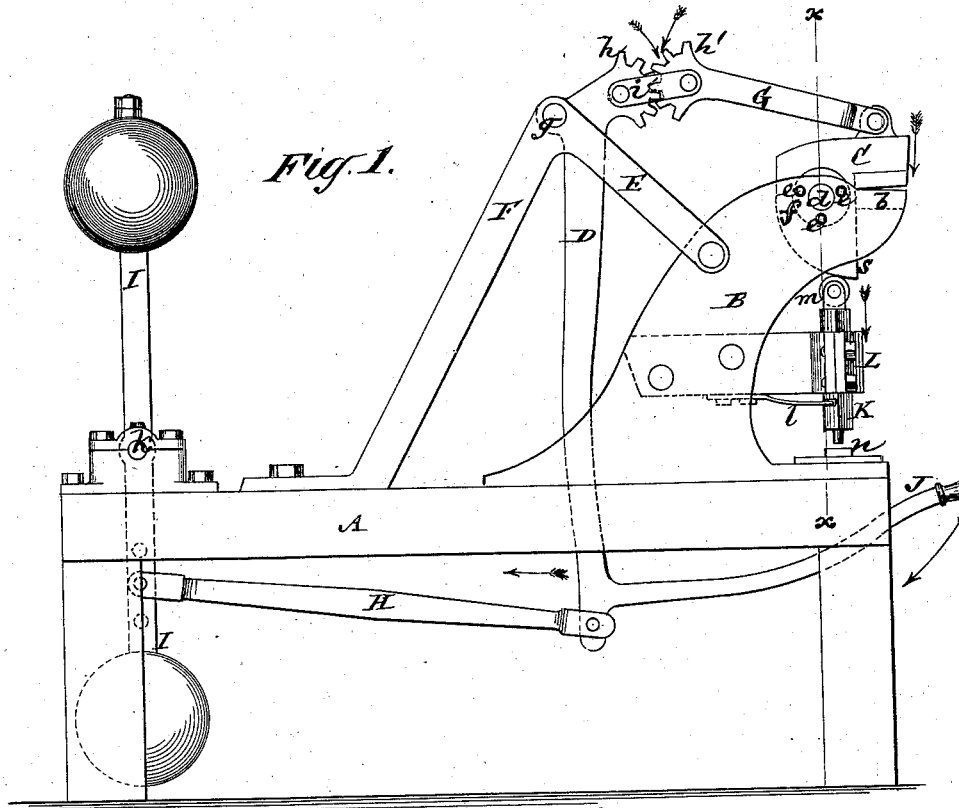
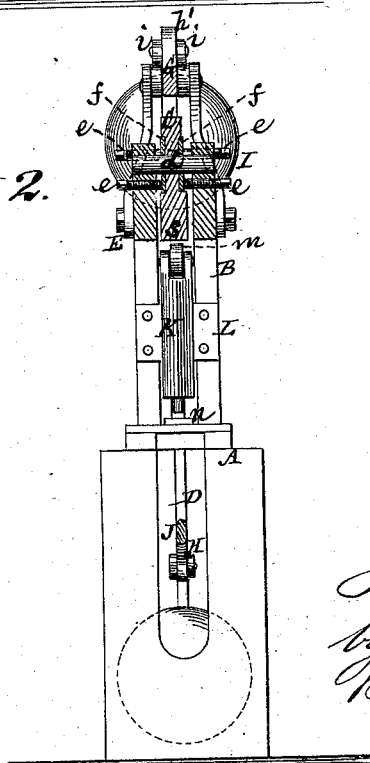

Fig. 2.



Witnesses
John Becker
Thos. Haynes

Hugh O'Neill
by his Attorneys
Brown & Allen

UNITED STATES PATENT OFFICE.

HUGH O'NEILL, OF NEW YORK, N. Y., ASSIGNOR OF ONE-HALF HIS RIGHT
TO JOANNA RITTERBAND, OF SAME PLACE.

IMPROVEMENT IN MACHINES FOR PUNCHING AND SHEARING METAL.

Specification forming part of Letters Patent No. 193,026, dated July 10, 1877; application filed
March 16, 1877.

To all whom it may concern:

Be it known that I, HUGH O'NEILL, of the city, county, and State of New York, have invented certain Improvements in Shearing and Punching Machines; and I do hereby declare that the following is a description of the same, reference being had to the accompanying drawing, forming part of this specification.

This invention relates to shearing-machines, or combined shearing and punching machines, designed to be operated by hand or by treadle.

The invention consists in a combination, with the working-blade of the shears, of certain means and mechanism for operating the same, and for controlling its action relative to the fixed blade of the machine, whereby a very lively and effective action, applicable to cutting both thick and thin work, is obtained.

Like advantages also accrue to the operation of the machine as a punch.

Figure 1 represents a side view of a combined hand shearing and punching machine constructed in accordance with my invention, and Fig. 2 a vertical transverse section of the same on the line *x x*.

A is a longitudinally-slotted bed, on the forward end of which is mounted a divided or split standard, B, that forms or carries at its upper front end the stationary blade *b* of the shears.

C is the working-blade of the shears, arranged to rock upon a fixed pin or fulcrum, *d*, carried by the standard B, and along which the blade C is made capable of adjustment by means of set-screws *e e*. These set-screws, which also steady and guide the working-blade C, are arranged on both sides of the standard B, and, passing through the cheeks of the latter, bear against washers *f f*, in opposite sides of the blade C, at suitable points around the fixed pin *d*. By means of these set-screws, the upper or working shear-blade C may be adjusted to cut more or less close to the lower or stationary blade *b* of the shears, to adapt the machine to shearing thin or thick work, and to provide for wear.

The following means are used to operate

the cutting-blade C of the shears: D is a pendent lever, having its fulcrum *g* on braces E F, connecting the standard B with the bed A. This lever is formed with an upper short arm, constructed to present a toothed sector, *h*, on the forward side of the fulcrum *g*. Said sector gears with another toothed sector, *h'*, on the rear end of a connected rod or bar, G, which is jointed or pivoted at its forward end to the shear-blade C.

Links *i i* serve to unite, at the pivots of the two toothed sectors *h h'*, the lever D with the rod G. The lower and longer arm of the lever D has connected with it, by a rod, H, a weighted fly, pendulous, or swinging balance lever, I. This lever, which vibrates on an intermediate fulcrum or pivot, *k*, may carry weights on both its upper and lower arms, and is swung or vibrated, to impart the necessary movement to the blade C, either by hand, through an arm or handle, J, applied to the lower end of the lever D, or by foot, through a treadle-connection with said lever.

K is the punch, which is operated against one or more springs, *l*, of any suitable description, by a cam, *s*, formed on the under side of the shear-blade C, which cam bears on a roller, *m*, attached to the punch. Said punch works through a guide, L, fast to the standard B, and operates in suitable relation with a lower female die, *n*.

The momentum of the balance or fly lever I, as it is swung or vibrated, saves "dead-pull," and gives a very lively and effective action, similar to that of a drop-press, and the pendulous lever I may, by virtue of the effect produced, be termed a "drop."

In a punching-machine thus constructed and operated, two or more blows in succession may readily be given to punch one and the same hole in metal of considerable thickness.

For light work the upper weight of the pendulous lever I may be removed, thereby reducing the momentum, also the labor of working the machine. Said lever I may, if desired, be made of considerable length, so as to project down into and work within a pit, and the lower pendulous weight of the lever

be shifted closer to or farther from the center of motion of the latter, as circumstances require.

I claim—

The combination of the pendulous or weighted vibrating fly-lever I, the connection H, the operating pendent lever D, the toothed sec-

tors *h h'*, the links *i*, the rod G, and the working-blade C of the shears, with its adjusting-screws *e e*, substantially as specified.

H. O'NEILL.

Witnesses:

FRED. HAYNES,
BENJAMIN W. HOFFMAN.