

A. M. SEARLS.  
PUMP.

No. 193,043.

Patented July 10, 1877.

Fig. 1.

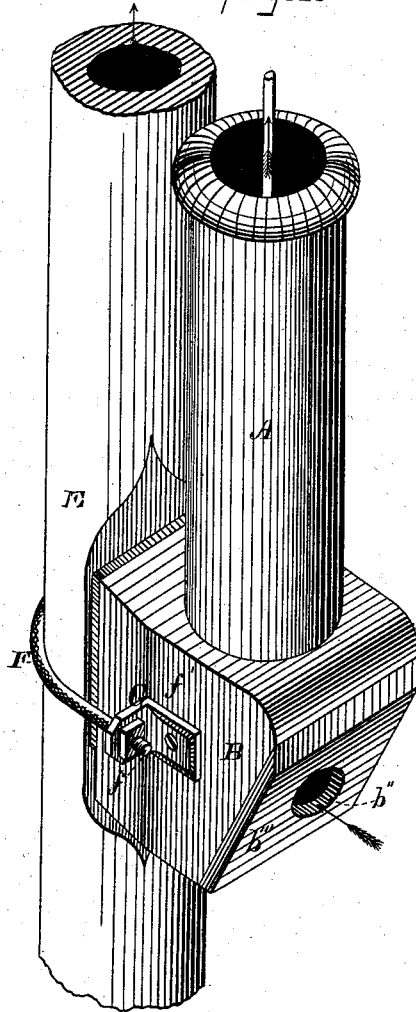

WITNESSES=  
*Geo. W. Hutchinson.*  
*Henry G. Hazard*

INVENTOR.  
*A. M. Searls, by*  
*Orindle & Co. his Attys*

A. M. SEARLS.  
PUMP.

No. 193,043.

Patented July 10, 1877.

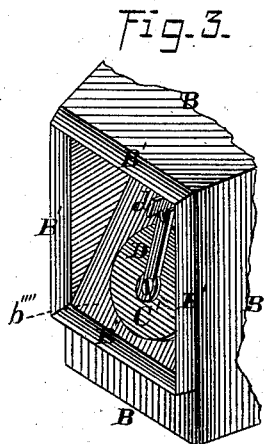
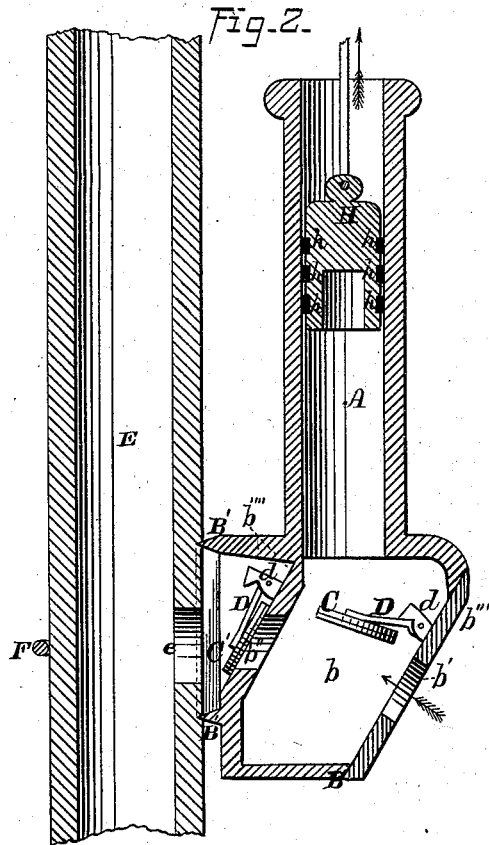

WITNESSES=  
*Jas. Hutchinson*  
*Henry G. Hazard*

INVENTOR  
*A. M. Searls*, by  
*Prindle & Co.* his Atty.

# UNITED STATES PATENT OFFICE.

AMBROSE M. SEARLS, OF GENESEO, ILLINOIS.

## IMPROVEMENT IN PUMPS.

Specification forming part of Letters Patent No. 193,043, dated July 10, 1877; application filed February 19, 1877.

### *To all whom it may concern:*

Be it known that I, AMBROSE M. SEARLS, of Geneseo, in the county of Henry, and in the State of Illinois, have invented certain new and useful Improvements in Pumps; and do hereby declare that the following is a full, clear, and exact description thereof, reference being had to the accompanying drawings, making a part of this specification, in which—

Figure 1 is a perspective view of my improved pump connected with a pump-log. Fig. 2 is a vertical central section of the same; and Fig. 3 is a perspective view of the outlet-valve, its seat, and the valve-box.

Letters of like name and kind refer to like parts in each of the figures.

The design of my invention is to lessen the cost of submerged pumps, to render the same more efficient, and to enable them to be more easily and quickly placed in or removed from position; to which end it consists, principally, in the peculiar construction of the pump-casing, substantially as and for the purpose hereinafter specified.

It consists, further, in the means employed for combining the pump-casing with the discharge-pipe, substantially as and for the purpose hereinafter set forth.

In the annexed drawings, A represents the barrel of my pump, which has a plain cylindrical form, is open at its upper end, and at its lower end is connected with and forms part of a valve-box, B, the lower end of the central opening in said barrel being in direct communication with the chamber *b*, between the inlet and outlet openings *b'* and *b''*, respectively.

The inlet-opening *b'* is formed within a side wall, *b'''*, of the valve-box B, which has an upward and outward inclination of about sixty degrees from a horizontal line, and upon the inner face of said wall is placed a round flat valve, C, that is pivoted at its center to or upon one end of a bar, D, the opposite end of which bar is hinged to a suitable support, *a*, at the upper side of said opening *b'*, the arrangement being such as to cause said valve to fall over and close the latter when not prevented by the inward flow of water.

As seen in Fig. 2, the valve-box opposite to the inlet-opening *b'* extends outward a dis-

tance nearly equal to the diameter of the bore of the barrel A, and within its outer face is provided with a valve-seat, *b''''*, which inclines upward and inward in a line parallel with the seat *b'''*, and incloses or contains the outer end of the outlet-opening *b''*. A valve, C', is in a like manner hinged so as to enable it, by the force of gravity, to fall over and close the opening *b''*.

Surrounding the recess that contains the outlet-valve and its seat is an A-shaped flange, B', which, preferably, incloses a square space, as shown by Fig. 3, and, when the pump is combined with a wooden pipe, E, is forced into the flattened surface of the same, so as to form a water-tight joint between said pipe and the space within said flange. An opening, *e*, from said space into the interior of said pipe enables water to pass into the latter from said pump.

The pump-casing and wooden pipe are combined by means of a metal strap, F, which passes around the latter, and has its threaded ends *f* contained within two lugs, G, that are secured to and project laterally outward from the sides of the valve-box B. A nut, *f'*, placed upon each of said threaded strap ends, in rear of said lugs, enables said strap to be drawn inward with sufficient force to embed the flange B' within said pipe, and closely confine the latter and said pump-casing together.

The pipe E is closed at some point below the opening *e*, so as to compel all water entering through the latter to pass upward.

Within the barrel A is fitted a plunger, H, which is solid, and is provided within its periphery with a number of concentric grooves, *h*, which become filled with water, that operates as a packing for said plunger. If desired, said grooves may be filled with rubber or any similar elastic material.

The operation of the pump will be readily understood. At each upward stroke of the plunger the inlet-valve C will be opened, and the interior of the casing will become filled with water, while upon the downward stroke of said plunger said inlet-valve will be closed, the outlet-valve C' opened, and said water will be forced into and through the pipe E.

The inclination given to the valve-seats en-

ables the valves to operate with greater ease and certainty than would be possible were said valve-seats vertical or horizontal, there being less weight to lift and distance to be moved than in the latter case, while the weight of said valves operates in a sufficient degree to cause them to automatically seat themselves.

In consequence of the manner of attaching the pump to the pipe, the former can be easily and quickly changed when desired, so as to cause it to occupy a position nearer to or farther from the bottom of a well.

Having thus fully set forth the nature and merits of my invention, what I claim as new is—

1. The hereinbefore-described pump-casing, consisting of the barrel A and valve-box B, provided with the inclined valve-seats  $b'''$  and

$b''''$ , and inlet and outlet openings  $b'$  and  $b''$ , the whole forming one casting, substantially as and for the purpose specified.

2. The means employed for combining the pump-casing with the pipe E, consisting of the  $\Lambda$ -shaped flange B', formed upon said casing, and capable of being embedded within the side of said pipe, and the strap F  $f$ , nuts  $f'$ , and lugs G, or their equivalent, substantially as and for the purpose set forth.

In testimony that I claim the foregoing I have hereunto set my hand this 11th day of January, 1877.

AMBROSE M. SEARLS.

Witnesses:

JNO. S. STEWART,

J. DE LOSS GRANT.