

J. MILLIGAN.

PLATE-PRINTING PRESS.

No. 193,097.

Patented July 17, 1877.

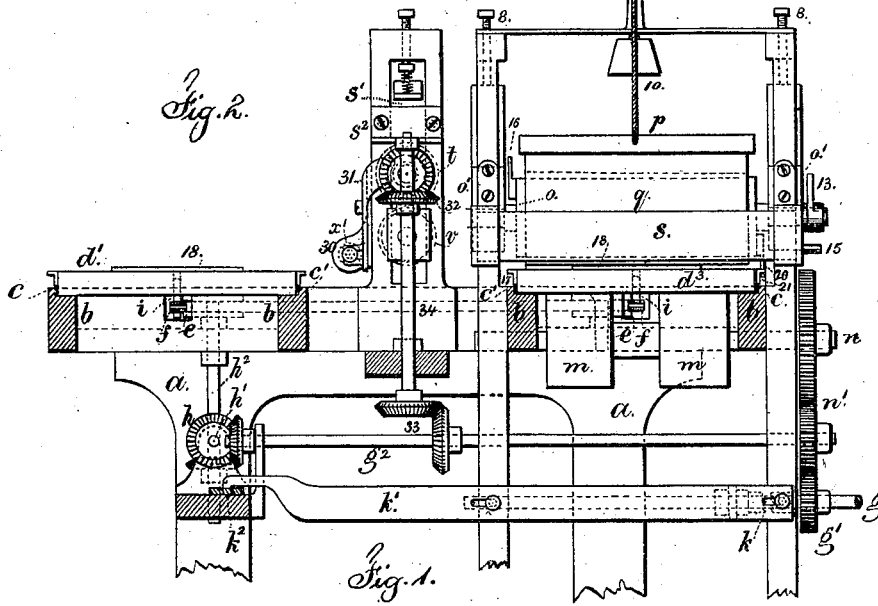

Fig. 1.

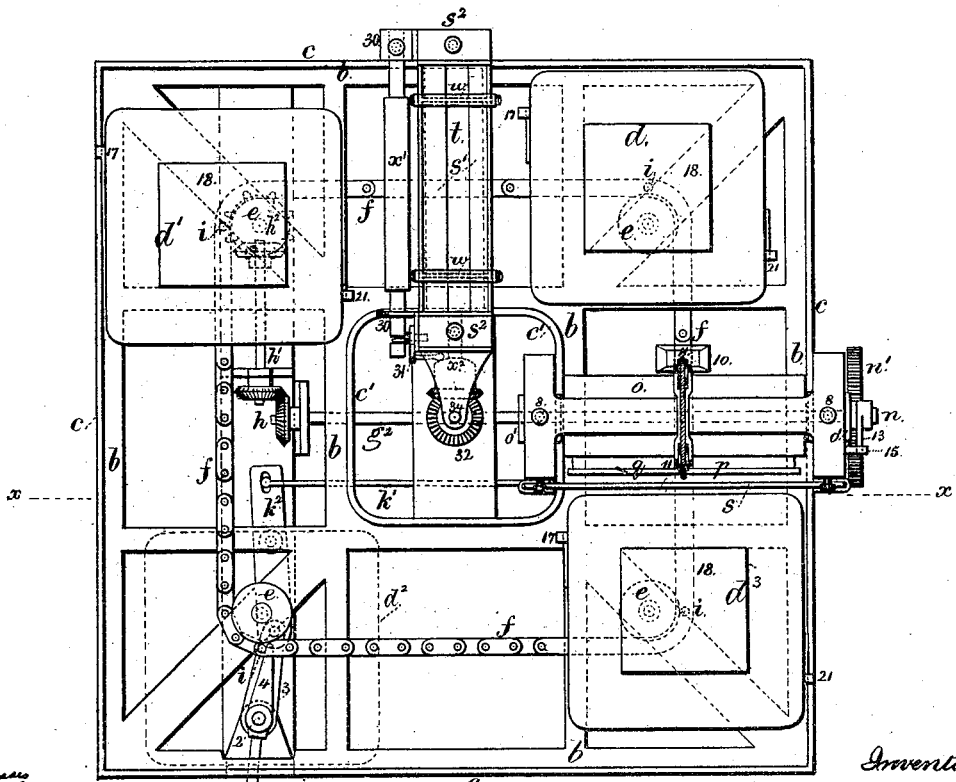

Fig. 2.

Witness
 Chas. H. Smith
 Harold Sewell

Inventor
 James Milligan
 per L. H. Powell atty

J. MILLIGAN.
PLATE-PRINTING PRESS.

No. 193,097.

Patented July 17, 1877.

Fig. 3.

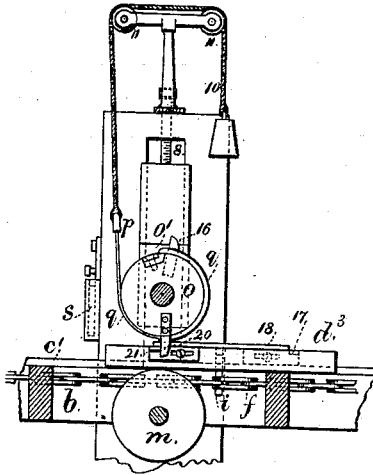

Fig. 4.

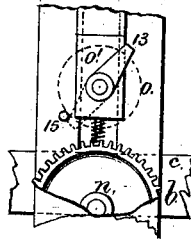

Fig. 5.

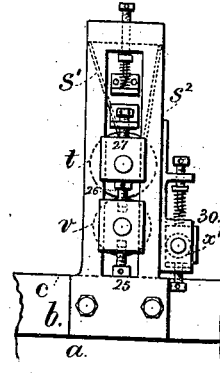

Fig. 7.

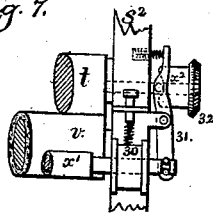
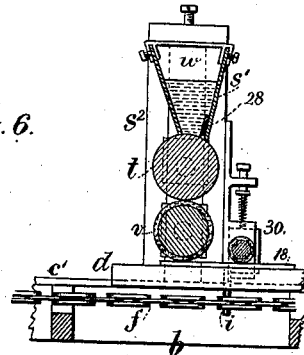

Fig. 6.



Witnesses

Chas. H. Smith
Harold Serrell

Inventor

James Milligan
per Lemuel W. Small
Atty

UNITED STATES PATENT OFFICE.

JAMES MILLIGAN, OF BROOKLYN, NEW YORK.

IMPROVEMENT IN PLATE-PRINTING PRESSES.

Specification forming part of Letters Patent No. 193,097, dated July 17, 1877; application filed February 1, 1876.

To all whom it may concern:

Be it known that I, JAMES MILLIGAN, of Brooklyn, in the county of Kings and State of New York, have invented an Improvement in Plate-Printing Presses, of which the following is a specification:

This invention is an improvement upon the press for which I have applied for Letters Patent by a specification dated April 23, 1875.

In my press the bed for the plate is carried along in a quadrangular or other polygonal frame by means of an endless chain passing around wheels, and the plate-bed or plank is stopped periodically for the successive operations of wiping, polishing, and supplying the sheet, and during the successive movements the sheet is printed, the impression removed, and then the plate is inked.

I make use of a peculiarly-arranged blanket in connection with stops upon the impression-roller and plate-bed, and the ink is supplied in a regulated quantity to the cloth roller, and rolled into the lines in the plate. A stop-motion is also provided, so that the movement of the bed is arrested automatically, and the parts can be coupled by hand as soon as the plate has been properly polished, so that the operations are proceeded with.

In the drawings, Figure 1 is a general plan of the press complete, except that one of the plate-beds or planks is removed to show the stop-motion. Fig. 2 is a vertical section at the line $x x$. Fig. 3 is a section showing the starting and maintaining fingers for the blanket-roller. Fig. 4 shows the stop for the impression-roller. Fig. 5 is an elevation of the inking apparatus, and Fig. 6 is a vertical section transversely to the inking-rollers.

The bed-frame of the machine is made polygonal, and preferably square. The frame a supports this bed-frame b , and the rim c outside and rim c' inside form guideways for the planks or plate-beds d d^1 d^2 d^3 . There are pulleys e located upon the diagonal cross-lines of the bed-frame, at such distances from the angles that the endless chain f , that passes around these pulleys, will travel centrally between the inner and outer guide-rims $c c'$, and upon this chain, at equal distances apart, are the four vertical pins i , that pass up from the chain into holes in the center of each bed.

By the movement of the chain the beds will be moved around progressively in the rectangular slideways upon the bed-frame between the guide-rims $c c'$. The power is applied to the shaft g , and by the gearing g^1 to the shaft g^2 , bevel-gears h , shaft h^1 , and bevel-gears shown by dotted lines in Fig. 1, that give motion to the vertical shaft h^2 of one of the pulleys e of the endless chain f , and this pulley is made as a sprocket-wheel, adapted to said chain to drive the same. There is a coupling-clutch, k , upon the shaft g , by means of which the power is connected to or disconnected from the wheel g^1 . This clutch may be of any desired character, and it is operated by the slide-bar k^1 , lever k^2 , vertical shaft 2, and arms 3 and 4. The end of the arm 4 is in the path of the projecting lower ends of the vertical pins i , so that as the chain moves along each pin i , as it comes around, will move said arm 4, shaft 2, arm 3, lever k^2 , and slide-bar k^1 , and uncouple the clutch k , so as to stop the motions of the machine. The bearing at the upper end of the shaft 2 is yielding, so that the arm 4 can be drawn back by the hand-knob 6, to clear the end of the arm 4 from the pin i , and allow the arms, lever, and slide to be moved back to recouple the power and start the press.

The object of this automatic stopping of the press is to give time for properly wiping and polishing the plates, after which the press is to be started to make another impression.

It is to be understood that there is to be an engraved plate upon each of the planks or plate-beds, and that, these being moved around progressively by the chain, the printing is done, as hereinafter described, while the plate and bed are moving from the position d^3 to d ; that the sheet is removed at the position d ; that the inking is done while the plate and bed move from d to d^1 ; that at the position d^1 the plate is wiped, and the plate is polished while the bed and plate are in the fourth position, (shown by dotted lines at d^2 ;) and as soon as the printer has properly polished his plate, he couples the power, and the beds are moved, bringing the polished plate to the position d^3 , ready to receive the sheet, and bringing the next plate to position for polishing.

If only one man wipes and polishes the

plate, these operations will be performed upon the plate while near the starting-lever.

It now becomes proper to describe the printing mechanism. There are sustaining and pressure rollers *m* beneath the plank or plate-bed at the point of impression, and these are upon a shaft, *n*, that is geared at *n'* to the wheel *g'*, so as to be moved at the same speed of travel as the plate-bed, and above this pressure-roller *m* there is the blanket-roller *o*, that is made adjustable vertically by its boxes or bearings being set in the vertical slides *o'*, in which are the adjusting-screws 8. This blanket-roller *o* is free to turn in its bearings, and one end of the blanket *q* is attached permanently to such roller, and the other end is provided with a cross-piece, *p*, and cord and weight 10 over the pulleys 11, so that the weight and blanket will turn the roller back after each impression until the arm 13 on the shaft of the blanket-roller (see Fig. 4) stops against the pin 15.

Upon one end of this roller *o* is a finger, 16, and upon each plate-bed *d* *d*¹ *d*² *d*³ there is a movable lug, 17. The object of these is to start the revolution of the roller *o* before the paper upon the engraved plate 18 comes into contact with the blanket, thereby preventing the sheet of paper being disturbed, because the lug 17 is positioned to take against the finger 16 just before the plate reaches the blanket. The lug 17 moves away from the finger 16 just as the full pressure of the blanket comes upon the plate, thereby allowing the blanket to be moved by the plate only, and thus preventing the paper being displaced by any difference in the speed of the blanket and plate, which would likely exist if the blanket-roller had a positive motion.

If the set of blankets are of uniform thickness, the paper will be pressed upon the edge of the plate. To prevent this and cut off the pressure upon the margin of the plate, the blankets are to be increased in number or thickness only where pressure is required upon the engraving; and I apply an adjustable finger, 20, upon one end of the blanket-roller, and an adjustable lug, 21, upon the plank, so that they come in contact just as the impression is finished, and the movement of the plank continues the revolution of the roller until the plate has passed entirely beyond the roller before the weight 10 can turn the blanket-roller and blanket back to the normal position; for if it were otherwise the paper might be injured or shifted by the weight keeping the blanket in contact with the paper, or turning it in the opposite direction before the sheet and plate are clear of the blanket.

There may be a plate of glass applied, at *s*, in front of the blanket-roller, and at a height adapted to allow the plate and paper to pass through beneath it. This glass plate becomes a guard, to prevent the fingers of the operative being drawn in beneath the blanket-roller, and at the same time the sheet can be watched and properly guided.

The inking apparatus is composed of a fountain or hopper, *s*¹, metal roller *t*, and cloth roller *v*. These are sustained in the side frames *s*². The roller *t* is revolved by power when the press is in motion; but the roller *v* receives its motion from the plate when in contact therewith, so as not to slide upon and wear the plate.

The screws 25 in the boxes of the cloth-roller journals serve to sustain the cloth roller at the proper height to come in contact with the surface of the plate. The screws 26 regulate the distance between the cloth roller *v* and metal roller *t*, so that the cloth roller *v* takes more or less ink off the roller *t* as they revolve, and hence the amount of ink that is transferred from one to the other is determined with great accuracy, and the screws 27 sustain the fountain and regulate the distance that there is between the roller and the lower edge of the fountain; hence there will be a wider or narrower opening for ink to escape. It is generally preferable, also, to have an adjustable knife at 28, (see Fig. 6,) that aids in regulating the amount of ink escaping upon the surface of the roller, between such roller and the edge of the knife.

It often happens that the engraved plate is narrow, or the engraving thereon occupies but a small portion of the plate. I arrange to supply ink only to the proper portions of the cloth roller *v*, and thereby save ink. To effect this the end plates *w* of the ink-fountain are made movable nearer to or farther from each other, so as to confine the ink to the proper position. These plates are preferably made with lips at their upper ends, passing over the upper edges of the side plates of the fountain, as seen in Fig. 6, and provided with screws, so as to clamp the plates in place against the edges of the fountain after the plates have been positioned to properly confine the ink to the place required.

It is important to fill in the ink into the lines. To effect this, one or more rollers, *x*¹, are mounted in adjustable bearings 30, and the plate passes beneath them, and they are pressed upon the plate by springs, and the shafts of these rollers slide freely through their bearings; and whenever the engraving is of such a character that the ink will be better filled in by giving an end motion to such rollers, I bring into action a lever, 31, that is applied between these shafts, and a zigzag cam, *x*², upon the shaft of the metal roller *t*, (see Figs. 1, 2, and detached Fig. 7,) so that the cam rocks this lever, and gives end motion to such roller or rollers *x*¹. The miter-gear wheels 32 33 and shaft 34 serve to communicate motion from the shaft *g*² to the shaft of the metal ink-roller *t*.

If this press is to be arranged with special reference to printing from a single plate, it is preferable that the inking-rollers and the blanket-roller be in line with each other at opposite sides of the bed, and that said bed, instead of being square, be made oblong.

I claim as my invention—

1. In combination with the ink-fountain *s*¹, metal roller *t*, cloth roller *v*, and side frames *s*², the screws 25, 26, and 27, and boxes of the respective rollers, to regulate the quantity of ink and the position of the inking-roller, substantially as set forth.

2. The combination, with a clutch and its slide and lever, of the arms 3 and 4 upon the shaft 2, the knob 6, and the studs *i* upon the chain *f*, substantially as set forth.

3. In a plate-printing press, in which the plates are carried beneath and move the blanket-roller, the combination of a blanket-roller, a blanket adapted to press upon the

engraved portion of the plate, and fingers and lugs for commencing the movement of the blanket before contact with the plate, then allowing the blanket to be moved by contact with the plate, and fingers and lugs continuing the movement of the blanket-roller as the plate and sheet move away from the said blanket, as specified.

Signed by me this 29th day of January, 1876.

JAMES MILLIGAN.

Witnesses:

GEO. D. WALKER,
GEO. T. PINCKNEY.