

K. C. ATWOOD.
INSECT-DESTROYING MACHINE.

No. 193,105.

Patented July 17, 1877.

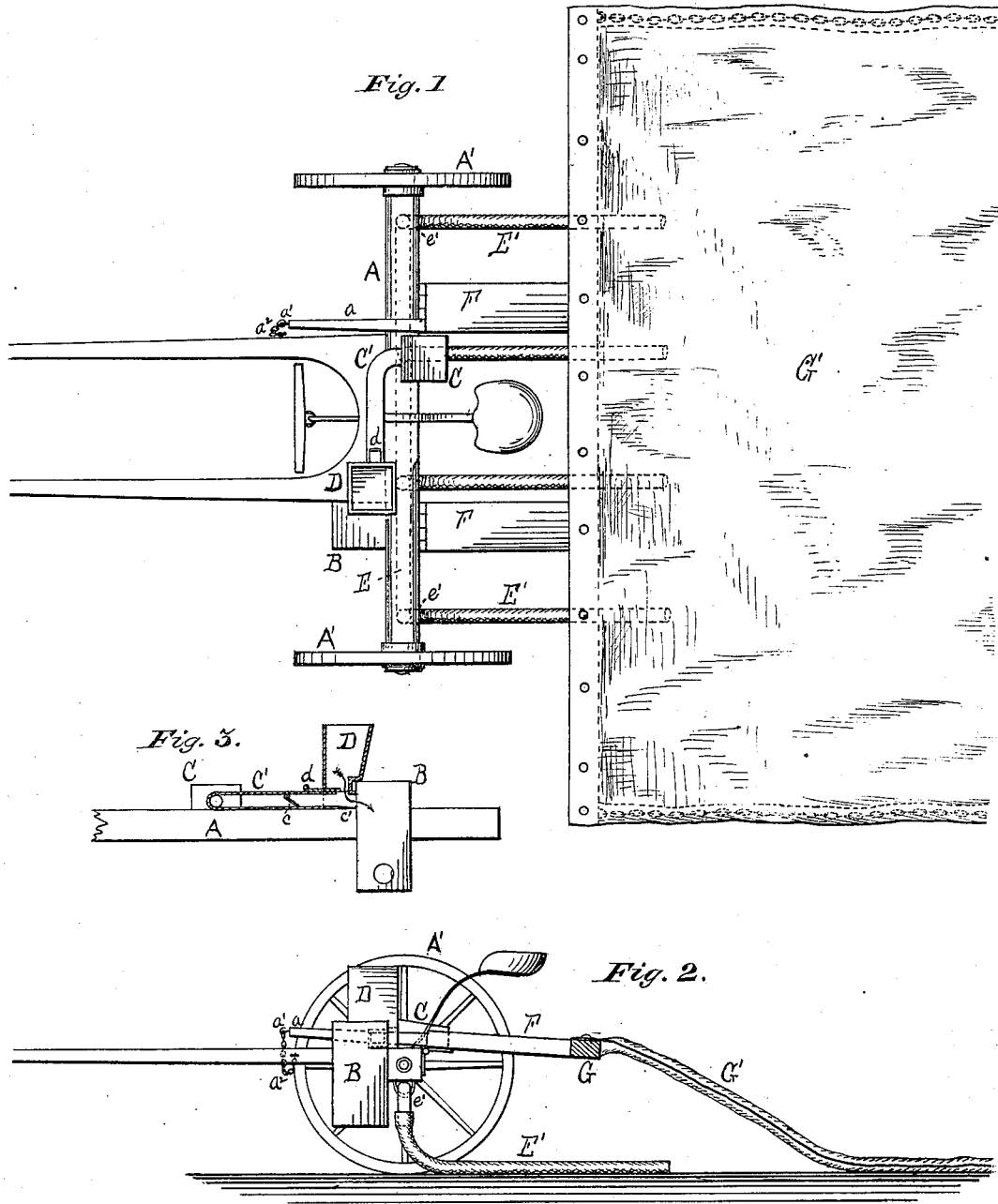

Witnesses:

J. C. Brecht,
John K. Jones.

Inventor

Kimball C. Atwood.
per Edm. James.
Asso: Attorney.

UNITED STATES PATENT OFFICE.

KIMBALL C. ATWOOD, OF NEW YORK, N. Y.

IMPROVEMENT IN INSECT-DESTROYING MACHINES.

Specification forming part of Letters Patent No. **193,105**, dated July 17, 1877; application filed June 21, 1877.

To all whom it may concern:

Be it known that I, KIMBALL C. ATWOOD, of the city, county, and State of New York, have invented certain Improvements in Machines for Destroying Insects, of which the following is a full, clear, and exact description, reference being had to the accompanying drawings, and the letters of reference marked thereon, making part of this specification, in which—

Figure 1 is a top plan-view. Fig. 2 is a side view, one wheel being removed. Fig. 3 is a sectional view of the stove, hopper, and blower, and the pipe connecting the same.

The object of my invention is the construction of a machine for destroying insects, such as grubs and worms in general, but is designed to be especially adapted to the extermination of the so-called western locust and the potato-bug.

The nature of my invention consists in attaching to the axle of the machine a light stove, and connecting the same with a blower or bellows by means of a tube. Surmounting this tube, and close to the stove, is located the hopper for the reception of the destroying compound, while the lower section of the stove is connected with an escape-pipe having attached thereto a series of flexible tubes, by means of which the fumes of the compound are carried to the ground. Attached by suitable means to the rear of the axle is a horizontal bar, to which is secured the apron or cover designed to prevent the escape of the fumes after being delivered by the flexible tubes.

The construction and operation of my invention are as follows:

A is the axle of the machine, and A' A' the wheels, all constructed in the usual manner. B is the stove, constructed of some suitable light material, preferably sheet-iron, and is attached to or near the axle A. This stove is designed to burn chips, wood, or charcoal. C is the blower or bellows, and is designed to be worked by the foot of the driver. If desired, this blower or bellows may be connected with the wheels by any suitable means and operated by traction. The blower or bellows C is connected with the top of the stove

B by means of a pipe, C', in which is located a valve, c, for the prevention of back currents. The end of this pipe C' which enters the stove is slightly inclined, as shown at c', Fig. 3. D is the hopper for containing the sulphur, phosphorus, or other suitable substance. This hopper has an orifice at its bottom, which registers with a suitable orifice in the tube C', and by this means the sulphur is conveyed to the tube, its flow being regulated by means of the sliding valve d. Connected with the lower section of the stove by means of a short pipe is a horizontal pipe, E, which is secured by suitable means to the bottom of the axle. This pipe E has attached to it a series of short tubes, e' e', to which are secured the flexible tubes E' E'. F F are bars which are hinged to the rear of the axle, and extend a distance sufficiently far from the same as not to interfere with the operation of the wheels.

To the free ends of these bars is secured a long horizontal bar, G, to which is attached the apron or cover G'. This apron or cover can be made of any light material suitable for the purpose, preferably of good sail-canvas or enamel-cloth, so that it may be easily wrapped up when the machine is not in use. The edges of this apron or cover G' are weighted to prevent it from blowing in case of wind, and also to enable it to more readily adjust itself to the uneven surface of the ground. To one of the bars F is secured a lever-handle, a, one end of which is provided with a hook, a'. By means of this lever-handle a and the chain a², attached to one of the shafts, the apron or cover G' is held in any desired position, being raised or lowered as occasion requires.

The operation is as follows: The sulphur or other insect-destroying compound is placed in the hopper D, the valve d being set to regulate the flow of the same into the pipe C'. The stove B having been properly charged with charcoal or other suitable substance, the same is lighted, and the blower or bellows C operated. This forces currents of air into the stove. The sulphur or other compound, falling on the burning charcoal or wood, becomes ignited, and the smoke or fumes thus produced finds vent into the escape-pipe E, from

which it is carried to the ground at the rear of the machine by means of the flexible tubes E' E', and confined by means of the apron or cover G'.

What I claim as new, and desire to secure by Letters Patent of the United States, is—

1. The apron or cover G', attached to the rear of an insect-destroying machine, to operate substantially as described, as and for the purpose specified.
2. In an insect-destroying machine, the

stove B, pipe C', blower C, hopper D, pipe E, flexible tubes E' E', and apron G', the whole constructed and arranged to operate substantially as described.

In testimony that I claim the foregoing I have hereunto set my hand this 19th day of June, 1877.

KIMBALL C. ATWOOD.

Witnesses:

J. B. BARRY,

CHAS. S. ENSIGN.