

C. FELDER.  
FLUTING-MACHINE.

No. 193,113.

Patented July 17, 1877.

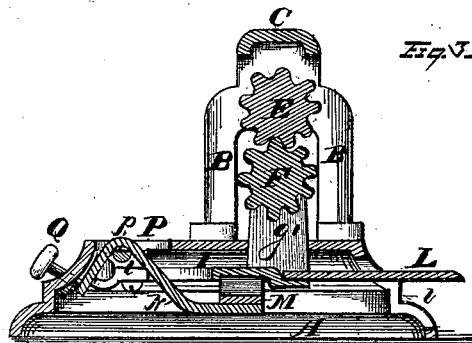
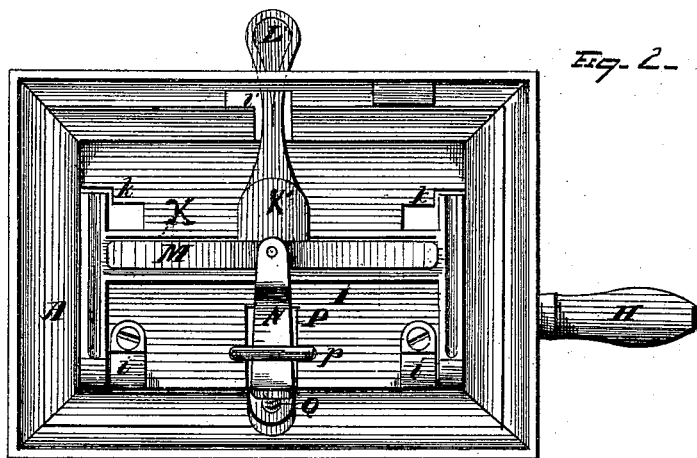
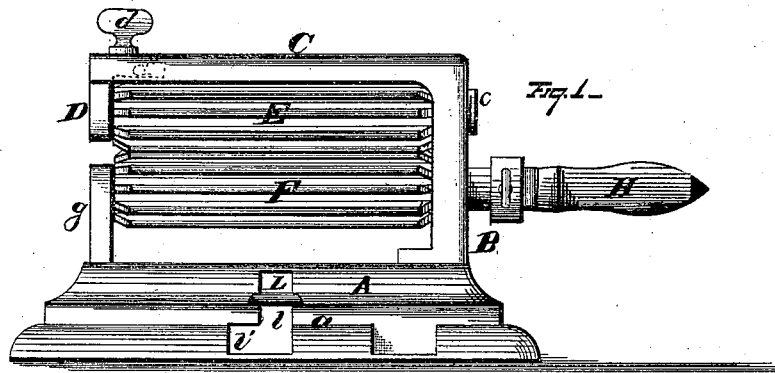

WITNESSES  
Ed. A. Nottingham.  
A. W. Dwight.

INVENTOR  
Charles Felder  
By Leggett & Leggett.  
Attorneys.

# UNITED STATES PATENT OFFICE.

CHARLES FELDER, OF NEW YORK, N. Y.

## IMPROVEMENT IN FLUTING-MACHINES.

Specification forming part of Letters Patent No. 193,113, dated July 17, 1877; application filed June 10, 1876.

*To all whom it may concern:*

Be it known that I, CHARLES FELDER, of New York, in the county of New York and State of New York, have invented certain new and useful Improvements in Fluting-Machines; and I do hereby declare that the following is a full, clear, and exact description thereof, which will enable others skilled in the art to which it appertains to make and use the same, reference being had to the accompanying drawings, and to letters of reference marked thereon, which form a part of this specification.

My invention relates to certain improvements in fluting-machines; and consists, first, in the combination, with an oscillating lower-roller frame, of an elliptic spring, adjustably secured against the rear side of its cross-bar, whereby the pressure of said roller may be varied by adjusting the tension of the spring; second, in the combination of the hand-lever and angular-arm lever with the intermediate acting spring.

In the drawings, Figure 1 is a front-side elevation; Fig. 2, a reverse plan, and Fig. 3 a central transverse section.

A is the main or bed plate, provided at its end where the power is applied with a forked supporting-standard, B, both lower forked extremities of which are firmly secured to the face of the bed-plate, while their upper ends unite in a rigid bridge over the lower roller. The overhanging bar C, continuously connected with this standard B, extends at right angles to same over the bed-plate and parallel to its length, forming at its free end an attachment with the journal-bearing D. This latter is secured to the overhanging bar by the thumb-screw *d* passing through said bar and engaging in a corresponding eye in the horizontal arm-plate *d'* cast in same piece with the journal-bearing. The upper roller E is trunnioned in this outer bearing D, and the inner bearing *c* formed in the standard B.

The lower roller F is journaled in the respective end bearings *g*, below the bearing D and *g'*, nearest the power application, which latter is obtained through any suitable crank mechanism, H, secured to the lower roller. These bearings *g g'* pass vertically downward through slots in the face of the bed-plate, and are cast at right angles to the frame I, which

latter is trunnioned at its opposite and rear extremity to the under side of the bed-plate in bearings *i i*. This frame I swings freely upon its bearings in a plane angular to that of the rollers, and is provided with the cross-piece K, connecting the two end strips *k k*, and cast in the same piece with same. These two end strips *k k* are cast with journals at their rear extremities, which journals are borne in the bearings *i i*.

A hand-lever, L, projects through a slot, *l*, formed in the front supporting side *a* of the bed-plate A, while its opposite extremity is pivoted to a segmental plate, *k'*, extending horizontally forward from the center of the cross-piece K. The slot *l* is laterally continued or elongated at its base so as to form a catch-piece, *l'*, whereby the lever, when depressed in separating the rollers, may be swung to one side and held down.

Pressing against the lower surface of the cross-piece K, at either end thereof, is the elliptic-spring M, of sufficiently strong construction to bear up the swinging frame and support the lower roller in close contact with the upper roller. To the center of the spring is pivoted the angular lever N, passing rearward and upward through the slot P in the back part of the bed-plate A, and over the bridge *p* formed across same, thence downward and bearing its rear extremity against the thumb-screw Q.

The construction of this lever is that of the first class, having its power end actuated by the adjustable setting of the thumb-screw Q passing through the rear supporting side of the bed-plate, while the weight end of the lever bears against the spring M, and the bridge *p* acts as a fixed fulcrum.

The operation of the parts is as follows: The thumb-screw Q is set at any suitable gage, and regulates the tension of the spring by the intermediate lever N. The spring bears against the cross-piece K, and serves to raise the swinging frame and retain same in a horizontal position. The lower roller approaches and separates from the upper fixed roller correspondingly, and in coincidence with the forward and back oscillations of this frame. The entire lower frame is pressed down, carrying the adjustable roller, by the hand-lever L,

which latter, when reaching the lower limit of its slot *l*, can be swung to one side and retained from the reactive spring by the catch-piece *v*.

The rollers may be of any suitable form, and of customary tubular construction, and constitute no part of my invention.

Having fully described my invention, what I claim as new, and desire to secure by Letters Patent, is—

1. The combination, with an oscillating lower-roller frame, of an elliptic spring, adjustably secured against the lower side of its cross-bar, substantially as and for the purpose described.

2. The combination of the hand-lever, swinging frame, elliptic spring, and adjustable angular lever supporting said spring, substantially as and for the purpose described.

In testimony that I claim the foregoing as my own I affix my signature in presence of two witnesses.

CHARLES FELDER.

Witnesses:

ROBERT VON CLEFF,  
LEOPOLD R. MAY.