

G. H. MILLEN & W. FEELY
STEAM-BOILER.

No. 193,126.

Patented July 17, 1877.

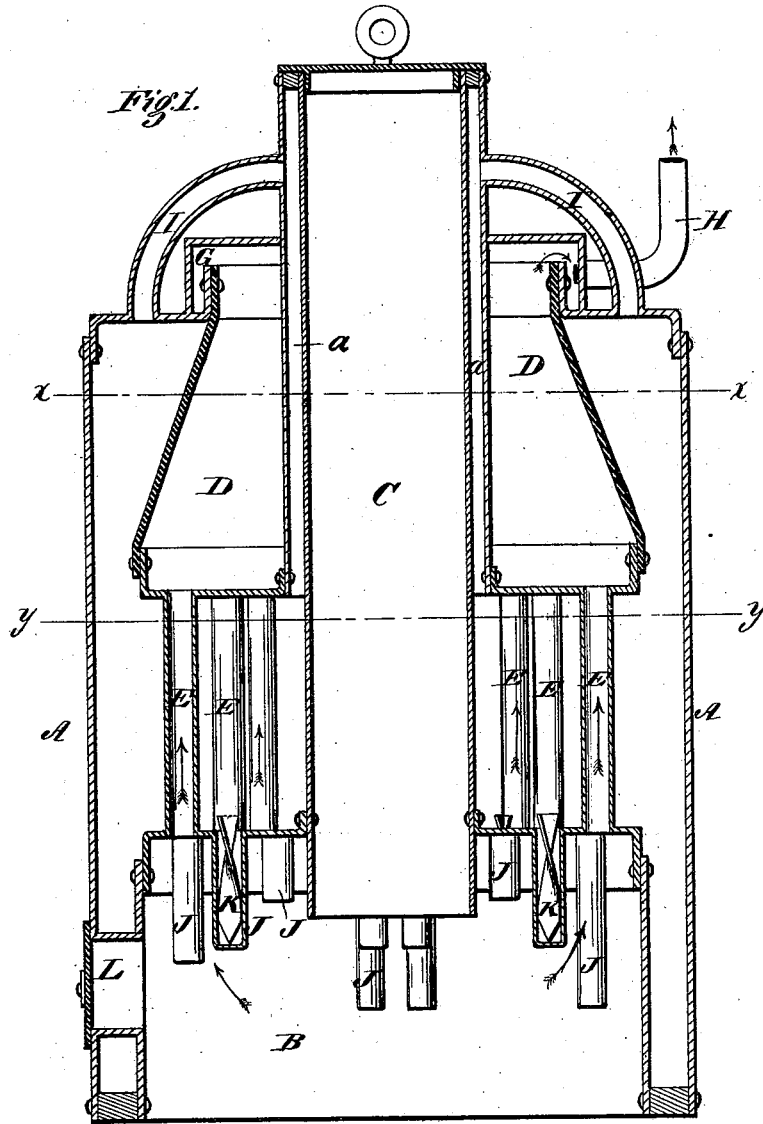

Witnesses:

Oron A. Twitchell
John L. Cochran

Inventor:

G. H. Millen
William Feely
By their Attyo.
Dodge & Son

G. H. MILLEN & W. FEELY.

STEAM-BOILER.

No. 193,126.

Patented July 17, 1877.

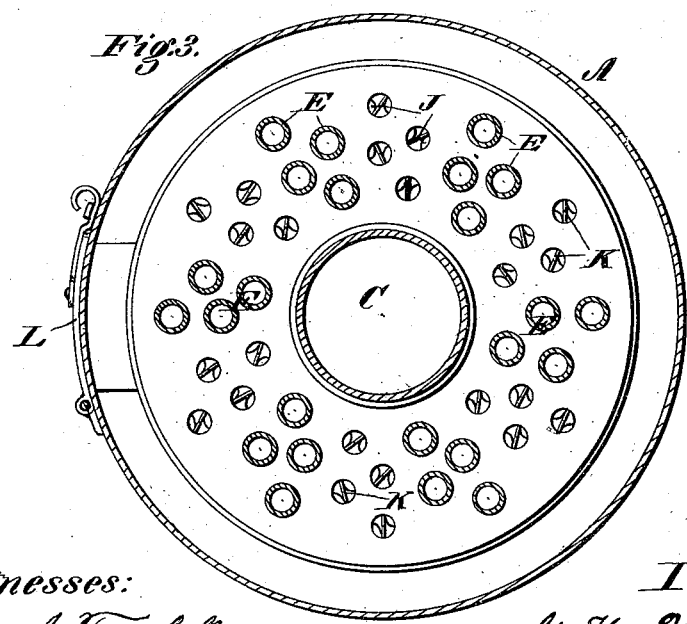
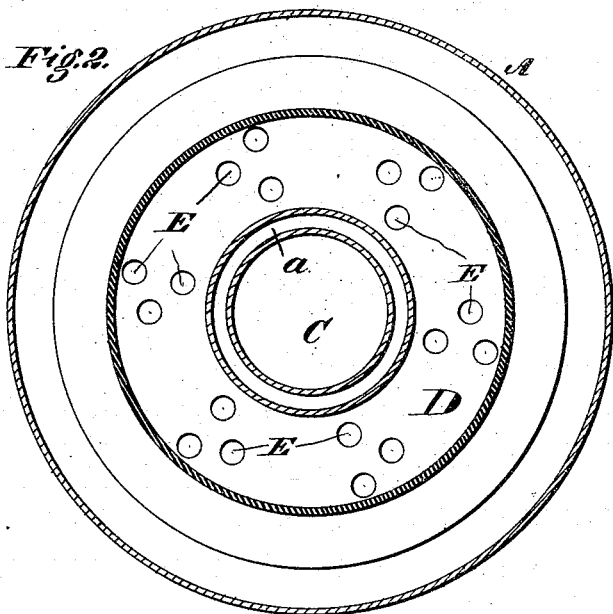

Witnesses:

Rory A. Twitchell
J. M. Pool

Inventor:

G. H. Millen
William Feely
By their attys
Dodge & Son

UNITED STATES PATENT OFFICE.

GEORGE H. MILLEN AND WILLIAM FEELY, OF HULL, QUEBEC, CANADA.

IMPROVEMENT IN STEAM-BOILERS.

Specification forming part of Letters Patent No. 193,126, dated July 17, 1877; application filed April 4, 1877.

To all whom it may concern:

Be it known that we, GEORGE HENRY MILLEN and WILLIAM FEELY, both of the city of Hull, in the county of Ottawa and Province of Quebec, Canada, have invented certain Improvements in Steam-Boilers, of which the following is a specification, reference being had to the accompanying drawings.

Our invention relates to upright tubular boilers; and consists in the employment of a central tube or reservoir to receive a supply of fuel and feed the same to the fire automatically, in combination with a water-jacket surrounding the same; in the use of pipes extending down within the fire-chamber, and containing rotary spiral blades to prevent the deposition of scale, and to assist in producing the circulation of the water and the liberation of the steam, and in other details.

Figure 1 represents a vertical central section of our boiler; and Figs. 2 and 3, cross-sections of the same on the line *x x* and *y y*.

A represents the outside cylindrical shell of the boiler; B, the fire-chamber, formed in the base of the boiler; and C, a vertical central tube, extending from the top of the boiler downward to the top of the fire-chamber, and forming an inlet and reservoir for the fuel.

As shown in the drawing, the upper end of the tube C is extended above the body of the boiler, and is surrounded by a water-jacket, *a*, which latter extends down into the boiler a considerable distance to form the inside wall of an annular smoke-chamber, D. The chamber D, which is formed, as shown, entirely within the body of the boiler, so as to be entirely inclosed by the water and steam, has its outside wall inclined inward toward its top, and is connected at the bottom by vertical flues E with the fire-chamber B, as shown. The flame and heated products of combustion, passing upward from the fire-chamber through the flues E into the chamber D, impinge against the inclined walls of the latter, and fill the interior space in such manner that the heat is rapidly and fully communicated to the surrounding water.

The upper outer wall of the chamber D is extended upward into a top chamber, G, provided with an outlet-flue, H, as shown, the

arrangement being such that the products of combustion are compelled to pass up over and descend on the outside of the wall in order to reach the outlet, whereby they are retarded and the waste of heat prevented.

From the top of the boiler, outside of the smoke-chamber D, tubes I are carried upward to the top of the jacket *a*, surrounding the central feed-tube, as shown.

This arrangement assists in equalizing the pressure, and conducts the steam into the upper part of the jacket, which is made to serve as a steam-dome and a superheating-chamber, the drying and superheating of the steam being effected by the hot gases and vapors in the chamber D, surrounding the jacket.

From the water-space of the boiler short tubes J are extended down into the fire-chamber, below its top or crown-sheet, the lower ends of the tubes being closed while their upper ends are open, so that they remain constantly filled with water. In each tube J there is mounted a spirally-twisted piece of sheet metal, K, as shown, supported loosely on a pivot, so as to rotate freely, as preferred.

The tubes extending down within the fire-chamber expose a very large surface, and greatly increase the heating capacity of the boiler. The loose spiral blades offer a sufficient resistance to the moving water to give the same a gyratory motion during its passage through and at the time of its emergence from the tubes, while at the same time the action of the water against the blades, and its resistance to the spiral motion, causes the blades to rotate, and thereby prevent the deposition of sediment or scale on the inner surfaces of the tubes.

We are aware that it is old to secure rigidly in a boiler-flue a central tube and a spiral rib encircling the same, and we lay no claim thereto, our invention being limited to the use of the spiral blades passing through the center of the flues and dividing the same into two equal spaces or spiral channels.

In constructing the boiler it will be provided with any suitable fire-grate in the chamber B, and with a door, L, in one side, to permit the inspection and the stoking of the fire. The top of the fuel-tube C will be closed with a plate, as shown, or other suitable device,

and the various valves, gages, feeding devices, &c., provided as usual.

In order to facilitate the descent of the fuel, the tube C will be made of increasing diameter toward its lower end; and in order that the feeding of the fuel may take place automatically, but without danger of being excessive, the mouth of the tube C will be carried down nearly to the usual level of the fire-bed.

Having thus described our invention, what we claim is—

1. The steam-boiler consisting of the body A, provided with the chambers B and D, flues E, tube C, and jacket *a*, as shown.

2. In a steam-boiler, the combination of the depending tubes and the loose spiral blades, dividing the same through the center, and serving to insure a circulation and prevent the deposition of sediment.

3. In combination with the top chamber G and outlet H, the smoke-chamber D, having its wall extended up into chamber G, as and for the purpose described.

4. In combination with the jacket *a*, communicating at its lower end and by the pipes I with the interior of the boiler, the chamber D surrounding said jacket, as shown, whereby the products of combustion are applied to dry and superheat the steam.

GEORGE HENRY MILLEN.
WILLIAM FEELY.

Witnesses:

D. C. SIMON,

Official Assignee, Hull.

E. D'ODET D'ORSONNENS,

Notary Public, Hull City.