

W. BECKLEY.  
BALLOON.

No. 193,136.

Patented July 17, 1877.

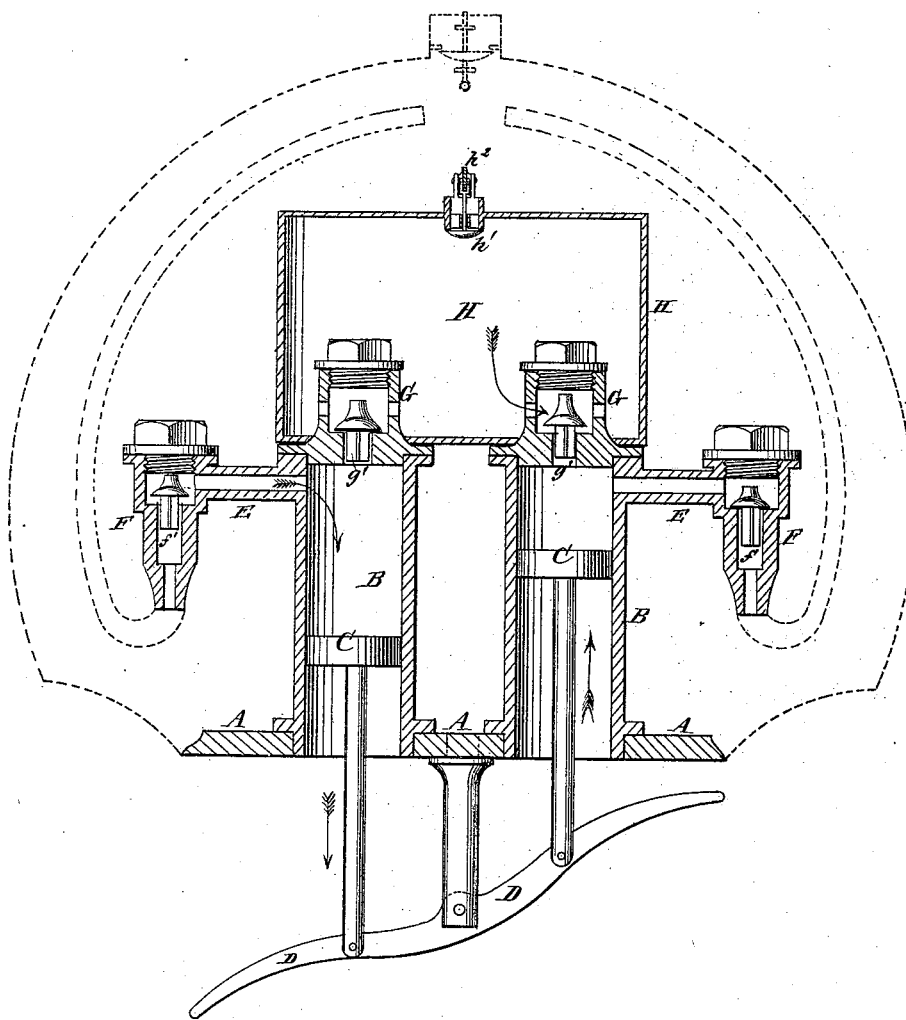

WITNESSES:

*A. W. Arngvist*  
*J. H. Scarborough.*

INVENTOR:

*W. Beckley.*  
BY *[Signature]*  
ATTORNEYS.

# UNITED STATES PATENT OFFICE.

WASHINGTON BECKLEY, OF LOUISA, KENTUCKY, ASSIGNOR TO HIMSELF,  
DAVID W. GARRED, AND MILLARD F. GARRED, OF SAME PLACE.

## IMPROVEMENT IN BALLOONS.

Specification forming part of Letters Patent No. **193,136**, dated July 17, 1877; application filed  
June 4, 1877.

*To all whom it may concern:*

Be it known that I, WASHINGTON BECKLEY, of Louisa, in the county of Lawrence and State of Kentucky, have invented a new and useful Improvement in Balloons, of which the following is a specification:

The figure is a vertical section of an apparatus illustrating my invention.

The object of this invention is to furnish balloons which shall be so constructed that they may be made to ascend and descend an indefinite number of times without varying the amount of gas in said balloons, and without the use of sand or other ballast, adapting them for use in aerial navigation, in raising stone and brick in erecting high buildings, and for various other purposes.

The invention consists in the mode of controlling the descent and ascent of balloons and other vessels floating in the air by the buoyancy of gas, by the compression and expansion of the gas contained within said balloons or vessels, and in the combination of the cylinders, one or more, provided with the valves opening inward, and the valves opening outward, and the condenser provided with the valve opening inward, with each other, to adapt them to be applied to a balloon for regulating the volume of the gas contained in said balloon to control its buoyancy, as hereinafter fully described.

A represents the base of a balloon or other vessel of any shape or size to be raised into or carried through the air by the buoyancy of gas.

To the base or platform A are attached one, two, or more cylinders, B, which project into the balloon, and within which work the pistons C.

The rods of the pistons C are pivoted to a lever, D, or other suitable means for operating them.

With the side of the upper part of the cylinders B is connected a short pipe, E, with the outer end of which is connected a valve-chest, F, provided with a valve,  $f'$ , opening inward.

With the upper end of the cylinders B is

connected a valve-chest, G, provided with a valve,  $g'$ , opening outward.

With the upper end of the cylinders B is connected a strong vessel, H, called by me a "condenser."

All the valve-chests G may open into the same condenser H, or each cylinder may have its own condenser. In the latter case the condensers should be connected with pipes.

In the top of the condenser H is placed a valve,  $h^1$ , opening inward, and the stem of which is connected with a lever,  $h^2$ , so that by operating the said lever  $h^2$  the valve  $h^1$  may be opened against the pressure of the compressed gas, to allow the gas to escape into the balloon. The lever  $h^2$  should be provided with a cord extending down to the basket or car of the balloon, to enable it to be conveniently operated.

The balloon should have a valve in its top in the usual way, to enable the gas to be discharged in the usual way should anything prevent the working of the gas-compressing mechanism.

I do not wish to limit myself to the gas-compressing mechanism herein described, as any apparatus that will compress the gas and allow it to expand, when required, may be used.

With this construction the balloon is filled with sufficient gas to raise and carry the desired weight. When the balloonist wishes to descend he operates the mechanism and compresses the gas into the condenser until the specific gravity of the balloon is greater than that of the air in which it floats, and it descends. Should the balloonist wish to check or stop his descent he opens the valve  $h^1$ , and allows enough gas to escape from the condenser H into the balloon to effect his purpose, so that he can ascend or descend any desired number of times without losing any gas, and without throwing out any ballast.

Having thus described my invention, I claim as new and desire to secure by Letters Patent—

1. The mode of controlling the descent and ascent of balloons and other vessels floating

in the air by the buoyancy of gas, by the compression and expansion of the gas contained within said balloon or vessels, substantially as herein shown and described.

2. The combination of the cylinders B, one or more, provided with the valves  $f'$ , opening inward, and the valves  $g'$  opening outward, and the condenser H, provided with the valve  $h^1$ , opening inward with each other, to adapt

them to be applied to a balloon for regulating the volume of the gas contained in said balloon to control its buoyancy, substantially as herein shown and described.

WASHINGTON BECKLEY.

Witnesses :

DANIEL VINSON,  
A. J. GARRED.