

C. E. BROWNELL.
 TWISTING-SPINDLES FOR MAKING CORDAGE.

No. 193,141.

Patented July 17, 1877.

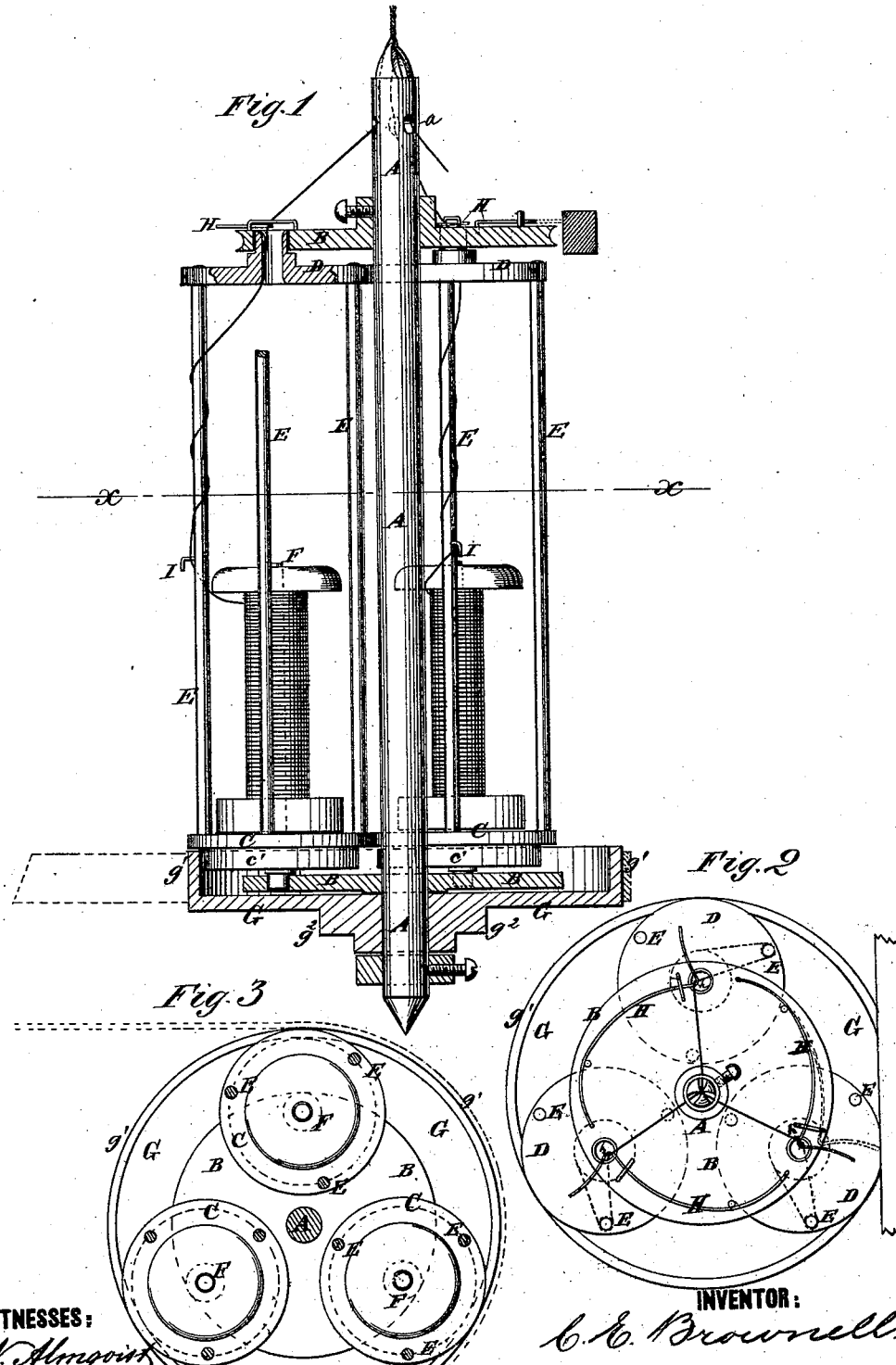

WITNESSES:
A. W. Almqvist
J. H. Scarborough

INVENTOR:
C. E. Brownell
 BY *Munn & Co.*
 ATTORNEYS.

UNITED STATES PATENT OFFICE.

CHARLES E. BROWNELL, OF MOODUS, CONNECTICUT.

IMPROVEMENT IN TWISTING-SPINDLES FOR MAKING CORDAGE.

Specification forming part of Letters Patent No. **193,141**, dated July 17, 1877; application filed February 3, 1877.

To all whom it may concern:

Be it known that I, CHARLES E. BROWNELL, of Moodus, in the county of Middlesex and State of Connecticut, have invented a new and useful Improvement in Twisting-Spindle for Making Cordage, of which the following is a specification:

Figure 1 is a longitudinal section of my improved spindle. Fig. 2 is a top view of the same. Fig. 3 is a cross-section of the same, taken through the line *xx*, Fig. 1.

Similar letters of reference indicate corresponding parts.

The object of this invention is to furnish an improved spindle for twisting twine and other three or more strand cordage, which shall be so constructed as to enable the twist to be made tight or loose, which shall be evenly balanced, and which will stop itself automatically should one of the strands break.

The invention will first be described in connection with the drawing and then pointed out in the claims.

A is the spindle, to which are attached two plates, B. In the plates B are formed holes, to receive the journals formed upon the end plates C D of the fliers.

To the centers of the lower plates C are attached the spindles F, upon which the spools are placed. Upon the lower sides of the lower plates C are formed ring-flanges *c'*, which bear against the ring-flange *g'*, formed upon the upper side of the edge of the plate G, so that the fliers may be revolved by the friction of the flanges *c' g'* as they are carried around by the spindle A and plates B. The plate G has a hole through its center for the passage of the spindle A and a hub, *g²*, upon its lower side to fit into a socket-bearing formed in the support for said plate G, which support is not shown in the drawings.

The outer surface of the flange *g'* serves as a pulley to receive a band, so that the plate G may be revolved in the opposite direction from the spindle A and plates B, when a tighter twist is required, and in the same direction with said spindle and plates when a looser twist is required.

The spindle A and plates B may be driven by a band passing around the edge of the upper plate B.

The upper journals of the fliers C D E F are made hollow for the strands to pass through them.

To the upper side of the upper plate B are attached the ends of springs H which have bends *h* formed in them near the hollow journals of the fliers, to receive the strands. The springs H are so formed that when left free their bends will be upon the outer sides of the hollow journals, and their outer ends will project beyond the periphery of the plate B. By this construction the tension of the strands will draw the free ends of the springs H inward; and, should the said strands break, the elasticity of the said springs will throw their outer ends outward, to strike against the frame of the machine or against stops, attached to said frame to stop the device and prevent waste of material. The springs H thus act as tension devices and as automatic stops.

The tension upon the strands may be varied by regulating the force of the springs H and increasing or diminishing the number of coils of the strands around the arms E.

I am aware that three tubes, corresponding to my fliers or planet-wheels, have been rotated by revolving against the inside surface of a stationary ring, giving the fliers a fixed number of revolutions to each one of the spindle; but my ring-plate G being loose on spindle A, can be driven at different velocities, thus imparting to the fliers any relative number of revolutions to one of the spindle. In this way the twist of the strands can be exactly adjusted to the last twist, so that the completed cord will not kink.

What I claim is—

1. The combination, with spindle, fliers, and plates B, as shown and specified, of the springs H, arranged on the upper plate B and having the bend *h*, as and for the purpose described.

2. The combination, with spindle, fliers, and plates B, of the loose ring-plate G, constructed and operating as and for the purpose set forth.

CHARLES E. BROWNELL.

Witnesses:

JAMES T. GRAHAM,
C. SEDGWICK.