

C. SILBERZAHN & H. HAYSSEN.

STRAW-CUTTER.

No. 193,189.

Patented July 17, 1977.

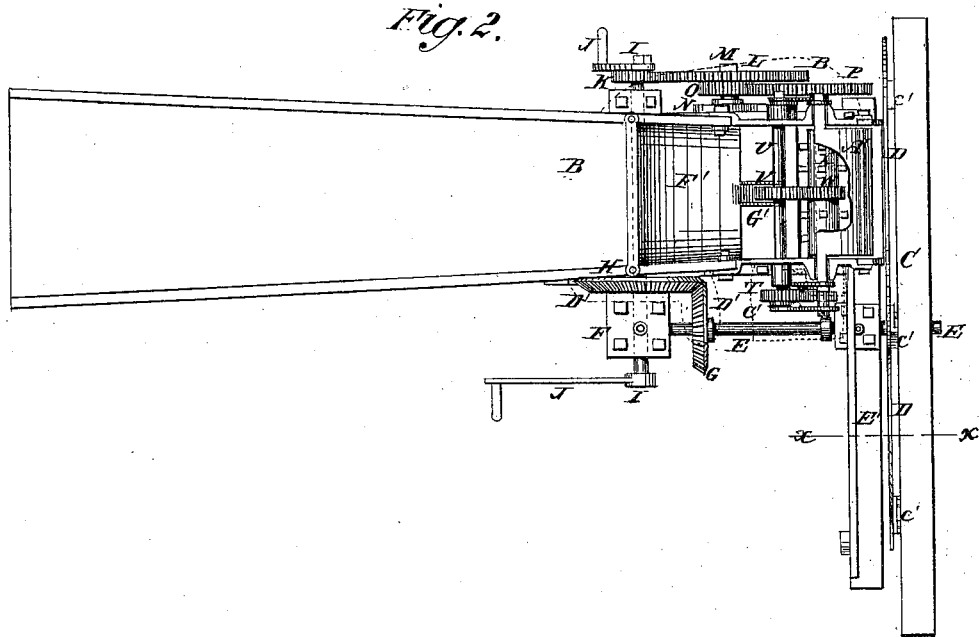
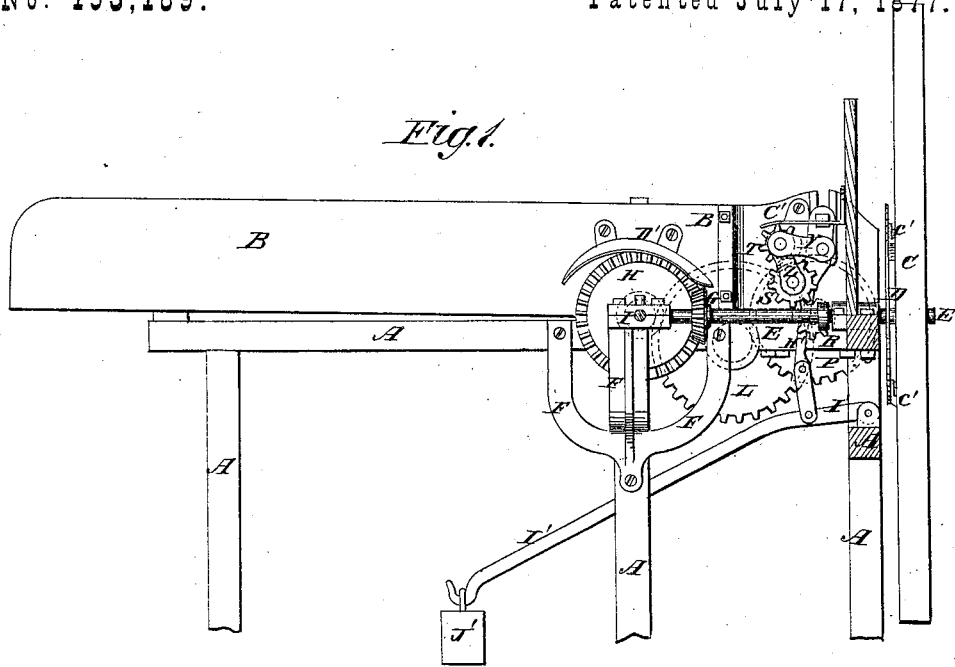

WITNESSES:

Francis McArdle.
J. H. Scarborough.

INVENTORS

C. Silberzahn.

H. Hayssen.

BY

M. M. M.

ATTORNEYS

C. SILBERZAHN & H. HAYSSEN.
STRAW-CUTTER.

No. 193,189.

Patented July 17, 1877.

Fig. 3.

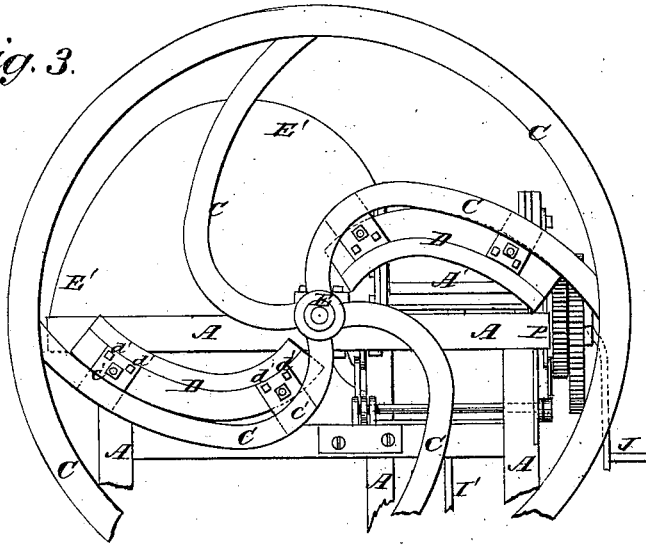

Fig. 6.

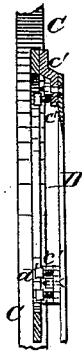

Fig. 4.

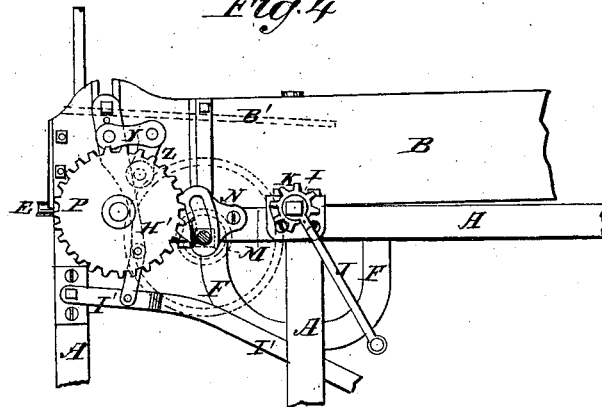
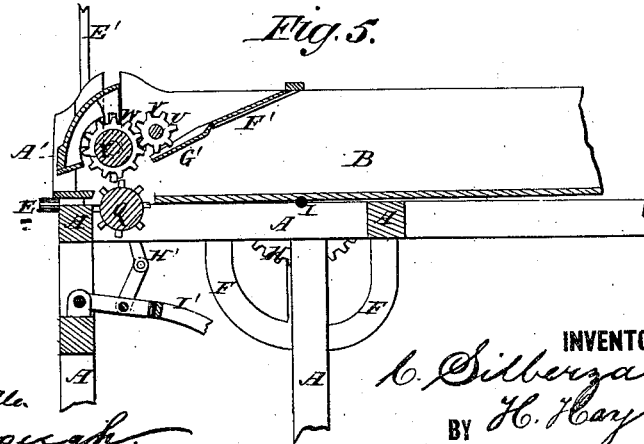

Fig. 5.



WITNESSES:

Francis McCordle
J. H. Scarborough

INVENTOR

C. Silberzahn
BY *H. Hayssen*
ATTORNEYS.

UNITED STATES PATENT OFFICE.

CHARLES SILBERZAHN AND HERMAN HAYSSSEN, OF SHEBOYGAN, WISCONSIN, ASSIGNORS TO SAID SILBERZAHN AND JOHN M. KOHLER, OF SAME PLACE.

IMPROVEMENT IN STRAW-CUTTERS.

Specification forming part of Letters Patent No. **193,189**, dated July 17, 1877; application filed February 17, 1877.

To all whom it may concern:

Beit known that we, CHARLES SILBERZAHN and HERMAN HAYSSSEN, of Sheboygan, in the county of Sheboygan and State of Wisconsin, have invented a new and useful Improvement in Feed-Cutter, of which the following is a specification.

Figure 1, Sheet 1, is a side view of our improved feed-cutter, partly in section, through the line *xx*, Fig. 2. Fig. 2, Sheet 1, is a top view of the same. Fig. 3, Sheet 2, is a front view of the same. Fig. 4, Sheet 2, is a reverse side view of the same, the fly-wheel being removed. Fig. 5, Sheet 2, is a detail longitudinal section of the same, the fly-wheel being removed. Fig. 6, Sheet 2, is a detail section of the fly-wheel.

Similar letters of reference indicate corresponding parts.

The object of this invention is to furnish an improved feed-cutter, which shall be so constructed as to make the cut evenly and easily, that will adjust itself to the thickness of the material being cut, and will feed the material forward uniformly, whether it be thin or thick, and which shall be simple in construction and convenient in use.

The invention will first be described in connection with the drawing, and then pointed out in the claim.

A is the frame of the machine, to the top of which the feed-box B is attached, and which is made with an L extension at its forward end, to prevent it from being tipped over or made unsteady by the weight of the fly-wheel C. The fly-wheel C is made with curved arms, and to two opposite arms are attached the knives D. The knives D are made with a gradually-increasing curve from their outer to their inner ends, so that all parts of their edges may meet the bottom of the feed-box B, upon which the material lies to be cut at the same angle.

The knives D are bolted to lugs *c'*, formed upon or attached to the arms of the fly-wheel C, and their edges are adjusted to work close to the end of the feed-box B by set-screws *d'*, which pass through screw-holes in the lugs *c'*, and rest against the said knives D. The for-

ward end of the feed-box B is lined with steel to prevent wear. The fly-wheel C is attached to the forward end of the shaft E, which revolves in bearings attached to the L of the frame A and to the bracket F attached to said frame A.

To the shaft E, near its rear end, is attached a bevel-gear wheel, G, the teeth of which mesh into the teeth of the larger bevel-gear wheel H attached to the shaft I. The shaft I passes through beneath the feed-box B, revolves in bearings attached to the frame A, and has a crank, J, attached to one or both ends.

To the shaft I, near its other end, is attached a small gear-wheel, K, the teeth of which mesh into the teeth of the larger gear-wheel L. The gear-wheel L revolves upon a spindle, M, the inner end of which is inserted in a curved slot in a casting, N, attached to the side of the frame A, and is secured in place in said slotted casting N by tightening up the nut that secures the gear-wheel L upon said spindle. This enables the gear-wheel L to be replaced by a larger or smaller gear-wheel, as may be desired.

Upon the gear-wheel L is formed, or with it is rigidly connected, a smaller gear-wheel, O, the teeth of which mesh with the teeth of the larger gear-wheel P attached to the journal of the lower feed-roller Q. The journals of the lower feed-roller Q revolve in bearings attached to the frame A, in such positions that the upper side of said roller may project through a transverse slot in the forward part of the bottom of the feed-box B.

To the end of the other journal of the feed-roller Q is attached a small gear-wheel, R, the teeth of which mesh into the teeth of a small intermediate gear-wheel, S, pivoted to the side of the feed-box B. The teeth of the intermediate gear-wheel S mesh into the teeth of the small gear-wheel T, attached to the end of the shaft V, which revolves in holes in the sides of the feed-box B, and to the center of which is attached a gear-wheel, V. The teeth of the gear-wheel V mesh into the teeth of the gear-wheel W formed upon the center of the upper feed-roller X, the journals of which revolve in vertical slots in the side-boards of the feed-box B. The holes in the sides of the

feed-box B, in which the journals of the shaft U revolve, are made larger than said journals, and the ends of the said journals are connected with the journals of the upper feed-roller X by bars or straps Y, and with the pivot of the intermediate wheel S by bar or strap Z, and with a stud in a corresponding position upon the other side of the feed-box B by a similar bar or strap, Z. This arrangement keeps the gear-wheels V W and the gear-wheels R S T in gear with each other as the upper feed-roller X moves up and down to accommodate itself to the thickness of the material.

With the journals of the upper feed-roller X are connected the ends of the presser A', which holds the material in place while being cut, and at the same time covers the upper and forward sides of the upper feed-roller X.

The gear-wheels L O P are covered by a cap, B', the gear R S T are covered by a cap, C', and the gear-wheels G H are covered with a cap, D', to prevent them from being clogged, and to protect the operator from being accidentally injured by them.

To the top bar of the L of the frame A is attached a shield, E', to protect the operator from coming in contact with the knives D.

To the upper forward part of the feed-box

B is attached an inclined plate, F', to guide the material into the space between the feed-rollers Q X, and which is provided with a grooved arm, G', to cover the lower side of the gear-wheel V, and prevent it from being clogged by the material.

With the journals of the upper feed-roller X are connected the upper ends of the straps or bars H', the lower ends of which are connected with the arms of the branched end of the lever I' by links or short connecting-bars. The forward end of the lever I' is pivoted to the front bar of the frame A, and from its rear end is suspended a weight, J', to hold the upper roller X and the presser A' down upon the material with the necessary force.

Having thus described our invention, we claim as new, and desire to secure by Letters Patent—

The combination, with the lower feed-roll, of the gear-wheels R S T and straps Z Y jointly with the upper feed-roll, with its center gear-wheel W and the shaft U, with its central gear-wheel B, as specified.

CHARLES SILBERZAHN.
HERMAN HAYSEN.

Witnesses:

JAMES M. CLEMENTS,
JOHN STÉHN.