

J. SMITH.

LEATHER-CRIMPING MACHINE.

No. 193,191.

Patented July 17, 1877

Fig. 1.

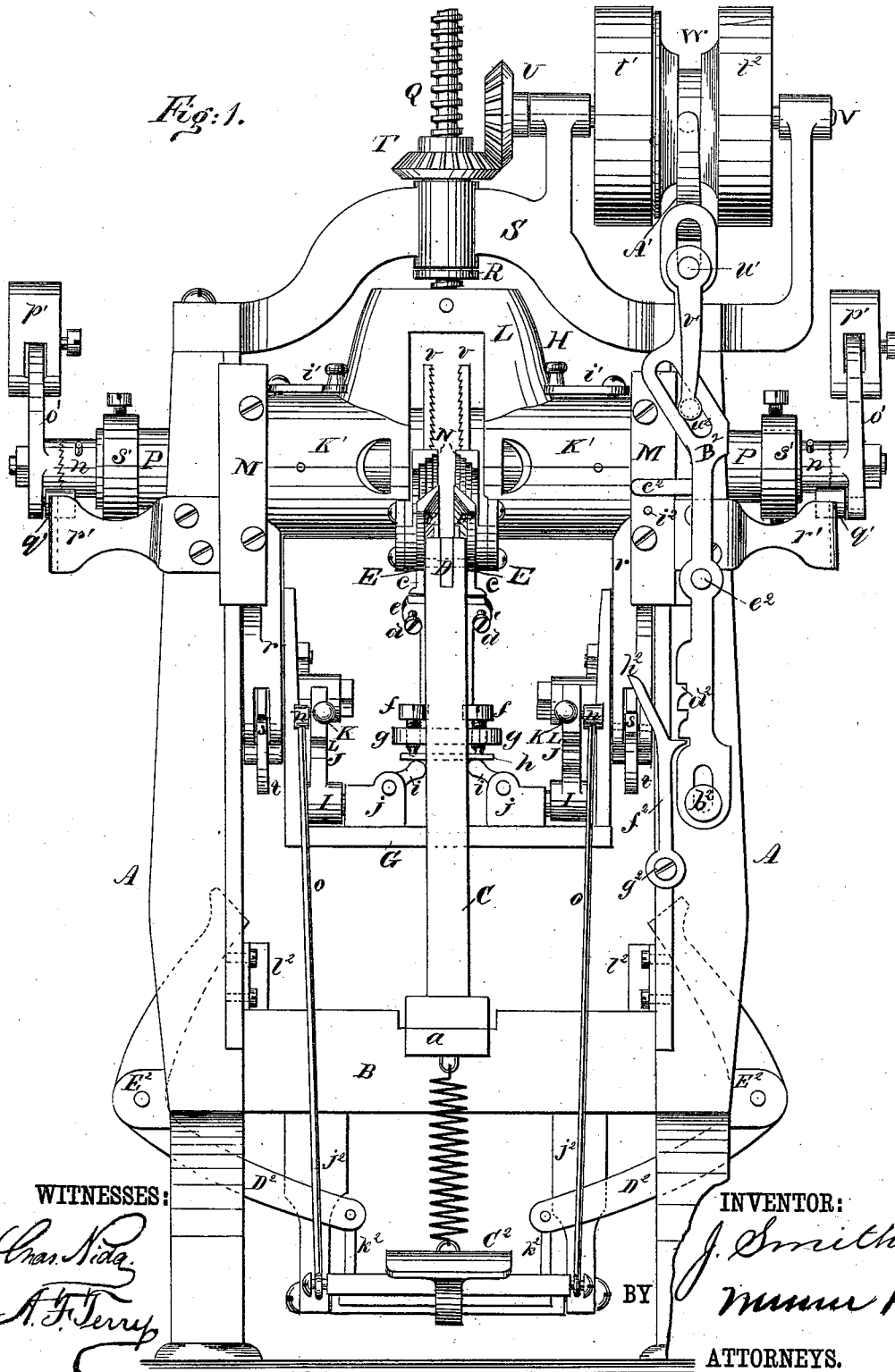

WITNESSES:

Chas. Nida
A. F. Terry

INVENTOR:

J. Smith
Wm. H. [unclear]

BY

ATTORNEYS.

J. SMITH.

LEATHER-CRIMPING MACHINE.

No. 193,191.

Patented July 17, 1877.

Fig. 2.

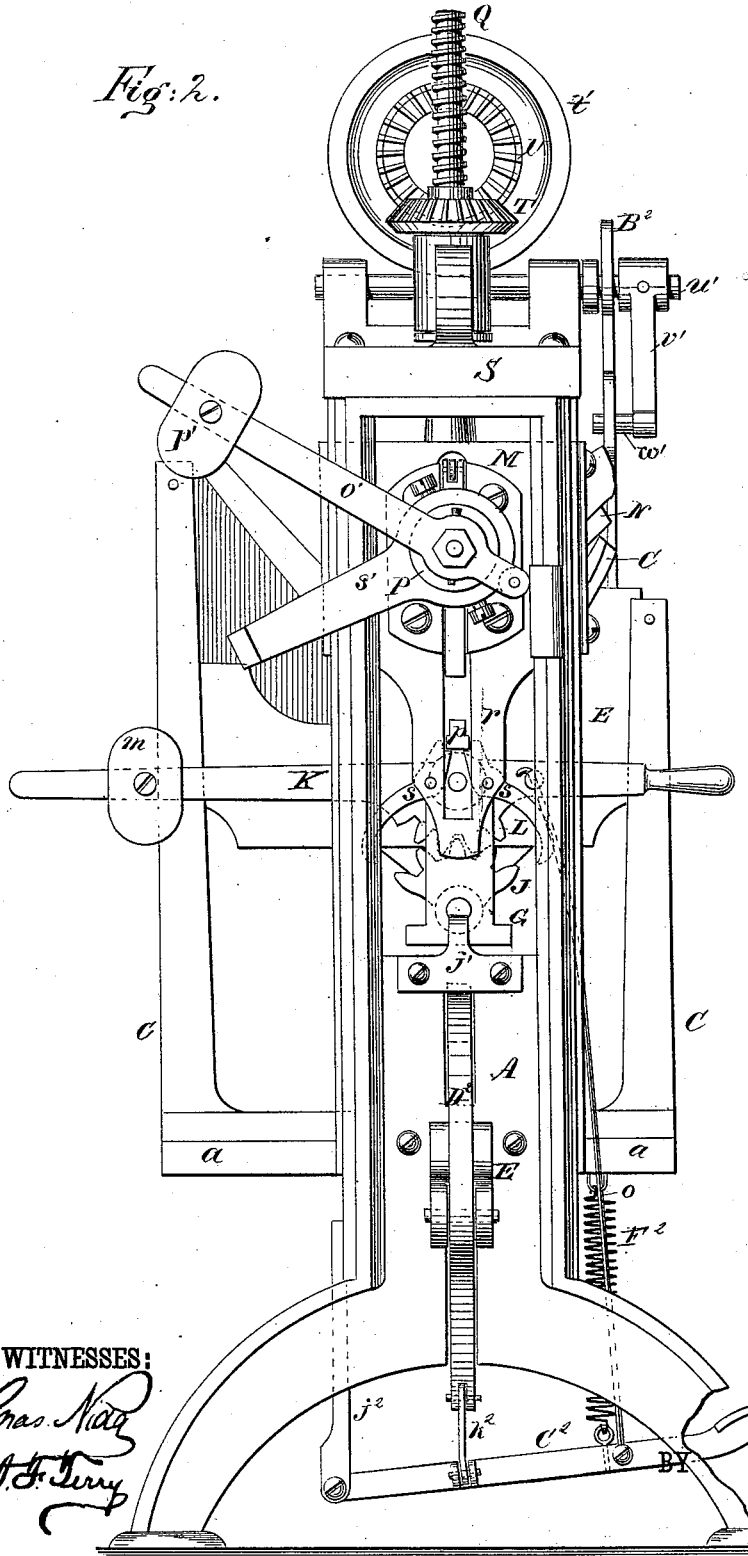

WITNESSES:

Chas. Niles
A. F. Terry

INVENTOR:

J. Smith
BY *Munn & Co.*
ATTORNEYS.

J. SMITH.

LEATHER-CRIMPING MACHINE.

No. 193,191.

Patented July 17, 1877.

Fig: 3.

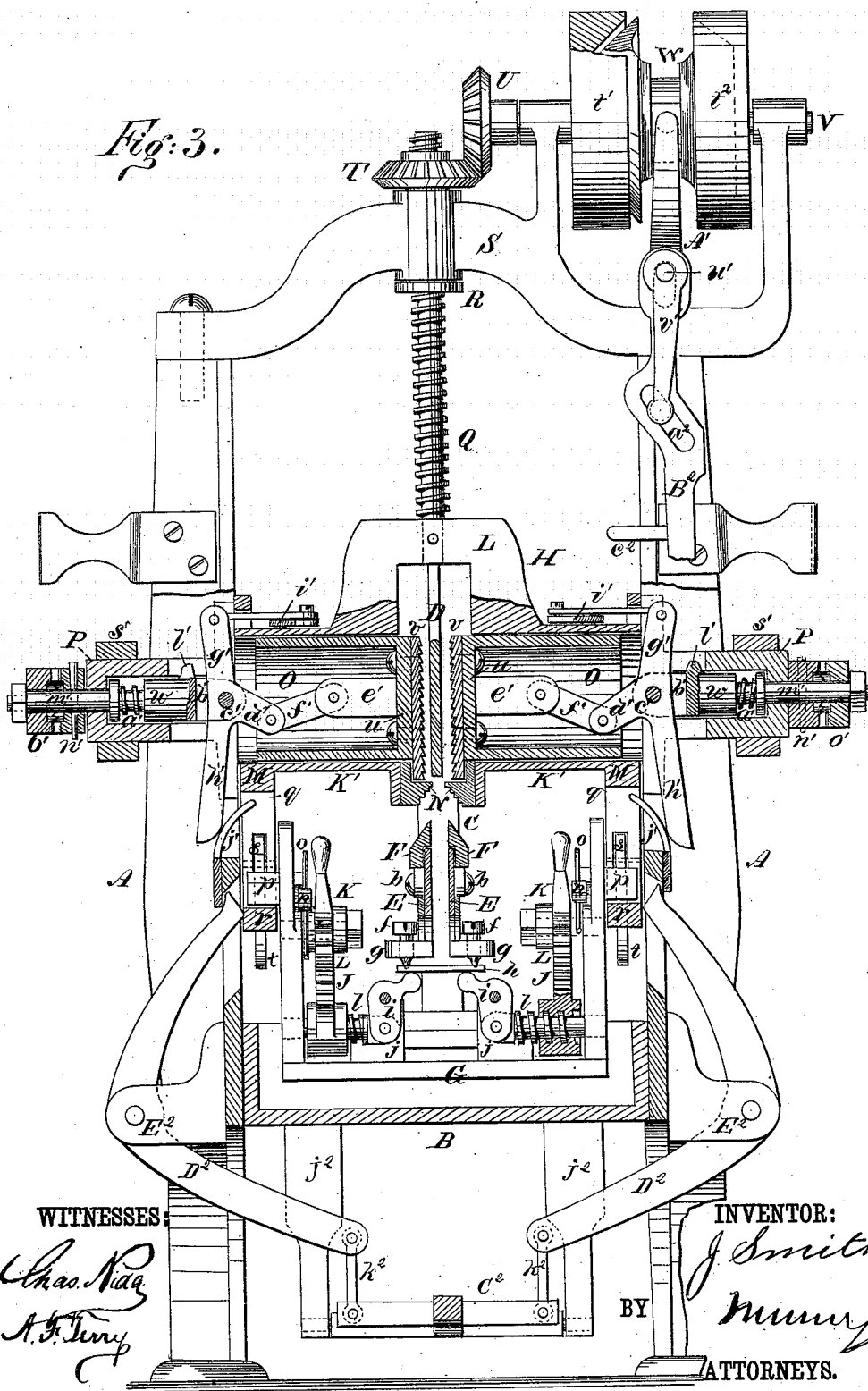

WITNESSES:

Chas. Naa
A. J. Terry

INVENTOR:

J. Smith.

BY

Munn & Co.
ATTORNEYS.

J. SMITH.

LEATHER-CRIMPING MACHINE.

No. 193,191.

Patented July 17, 1877.

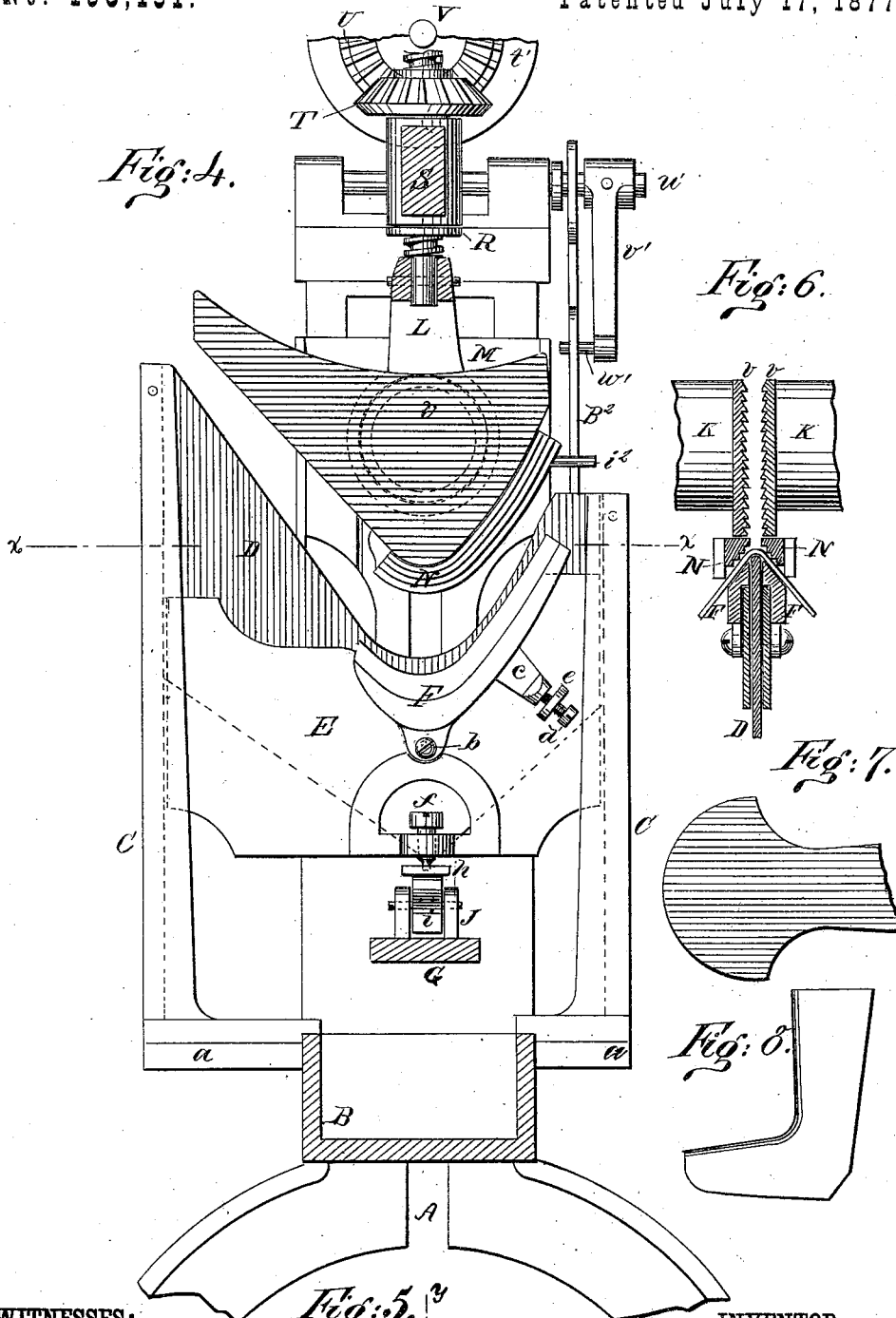

WITNESSES:

Chas. N. Day
A. F. Terry

INVENTOR:

J. Smith
BY *Munroe*
ATTORNEYS.

UNITED STATES PATENT OFFICE.

JASON SMITH, OF CHARLESTOWN, MASSACHUSETTS.

IMPROVEMENT IN LEATHER-CRIMPING MACHINES.

Specification forming part of Letters Patent No. 193,191, dated July 17, 1877; application filed June 4, 1877.

To all whom it may concern:

Be it known that I, JASON SMITH, of Charlestown, county of Suffolk and State of Massachusetts, have invented a new and Improved Leather-Crimping Machine, of which the following is a specification:

Figure 1 is a front elevation of my improved leather-crimping machine. Fig. 2 is a side elevation. Fig. 3 is a front elevation in part section. Fig. 4 is a central vertical section. Fig. 5 is a horizontal section on line *x x*, in Fig. 4 of the crimping-plates and tree or form. Fig. 6 is a transverse section, taken on line *y y*, in Fig. 5. Fig. 7 represents the top or upper before being crimped; and Fig. 8 represents the same after it is crimped.

Similar letters of reference indicate corresponding parts.

The object of my invention is to furnish a machine for crimping the uppers of boots and shoes without unduly straining the leather; and which will leave the upper in the desired form without thickening it at the instep or ankle.

My invention consists in the arrangement, in a suitable frame, of a tree or form rigidly supported by standards attached to a cross-bar of the frame, and in plates that slide in grooves in the said standards, one upon either side of the tree, and carry wedge-shaped or beveled pieces, having the same curvature as the tree or form.

It also consists in a clamping device for clamping the leather, and carrying it down over the tree, and in smoothing-plates for pressing the leather smoothly upon the tree, and in levers and screws for operating the various parts, as hereinafter more fully described.

Referring to the drawings, A A are side pieces of the frame that support the various parts of the machine; B, the lower cross-piece, and C C are standards attached to the brackets *a* formed on the said piece.

A tree or form, D, is supported by the said standards, it being placed in slots formed in the upper ends of the standards and secured by pins. The tree is placed with its concave edge uppermost, and on each side of it plates

E are placed, which are guided by grooves formed in the standards C.

To each of the plate E, a curved beveled piece, F, is pivoted at *b*, the curvature of which is the same as that of the tree D. The pieces F are provided with projections *c*, which are engaged by screws *d*, that extend through ears *e*, attached to the plates E. The pieces F, being placed on opposite sides of the tree D, must of necessity, be right and left. Adjusting-screws *f* pass through ears *g*, that project from the corners of the plates E at their lower edges. These screws rest upon the plate *h*, which is supported by levers *i*, that are pivoted in the blocks *j* formed on or attached to the frame G, which is supported by the head H, which will be presently described. To each of the levers *i* a screw, *l*, is jointed, which is turned down to form a guide that extends through the side of the frame G, and upon which is placed a nut, I, having formed on it the toothed sector J. Above this nut a lever, K, is pivoted to the side of the frame G, and is provided with a toothed sector, L, that engages the sector J on the nut I.

The lever K is formed into a handle at the front of the machine, and is provided with an adjustable weight, *m*, at the rear of the machine, and an eyebolt, *n*, through which a rod, *o*, passes. These levers and their connections in each side of the frame G, aside from being right and left, are precisely alike.

The frame G is provided with studs *p*, which slides in slots *q* formed in the projections *r*, that extend downwardly from the end pieces of the head H. Dogs *s* having the curved ends *t* are pivoted in the sides of the part *r*, and are capable of engaging the studs *p*, when the frame H passes downward, and the frame G is supported by a device, hereinafter described.

The head H consists of two hollow cylindrical parts, K', connected by a yoke, L, and provided with end pieces M that are fitted to ways formed on the side pieces A of the main frame. To the lower side of the parts K' corrugated curved beveled pieces N are secured. These pieces N are the counterpart

of the pieces F on the plates E, and when brought into contact with the said pieces E, they clamp the leather with sufficient pressure to draw it evenly over the tree in the operation of crimping.

A tubular follower, O, having a head, *u*, is fitted to each of the cylindrical parts K', and to each of the heads *u* a corrugated plate, *v*, is attached, which is fitted to a rabbet formed in the upper side of the ribbed piece N.

A sleeve, P, projects from the end piece M through a slot in the side of the main frame, and contains a sliding nut, *w*, that is moved by a screw, *a*¹, and is provided with ears *b*¹, between which the three-arm lever *c*¹ is pivoted. The arm *d*¹ of the said lever projects into the follower O, and is connected with a stud, *e*¹, that projects from the inner surface of the head *u* by a link, *f*¹. This arrangement forms a toggle, by which the follower O may be forced out and locked.

The sleeve P is slotted, and the arm *g*¹ of the lever *c*¹ projects upward, and the arm *h*¹ downward through the sides of the sleeve. The arm *g*¹ is connected to an angled lever, *i*¹, pivoted at the top of the part K¹, and the arm *h*¹ is rounded, so as to be engaged by a cam, *j*¹, that is attached to the side piece A of the main frame. The nut *w* is provided with a feather, *l*, that projects into the slot in the sleeve P to prevent it from turning.

The screw *a*¹ is formed on a spindle, *m*¹, that extends through the end of the sleeve P, and is provided with a collar, *n*¹, having a serrated or radially-grooved face, and it is also provided with a thread and nut at its outer end, for clamping the lever *o*¹ (which is also provided with a serrated or grooved face) against the serrated face of the collar *n*¹. One arm of the lever *o*¹ is provided with a weight, *p*¹, and the other is provided with a roller, *q*¹, that is engaged by an arm, *r*¹, that projects from the side piece A. An arm, *s*¹, is fitted to the sleeve P, and clamped by a set-screw in any required position. The outer end of this arm is bent at right angles, and forms a stop for the lever *o*¹.

The various parts described are similar in both ends of the head H.

A screw, Q, is secured to the yoke L, and extends upward through an internally-threaded sleeve, R, that is journaled in the top piece S of the frame of the machine, and upon which is placed a miter-wheel, T, that is driven by a miter-wheel, U, on the end of the shaft V, which is journaled in standards that project upward from the top piece S. Upon the shaft V two pulleys, *t*¹ *t*², are placed loosely, and capable of being engaged by a friction-clutch, W, placed on the shaft V, and carried by a spline. The said clutch is moved by a forked lever, A', placed on a rocking shaft, *w*¹, journaled in the top piece, and provided with an arm, *v*¹, which extends downward, and is provided with a stud, *w*¹. This stud is received by a diagonal slot, *a*², in the bar B²,

which is slotted at its upper and lower ends, and is guided by the shaft *u*¹, and by the stud *b*².

This bar is provided with an arm, *c*², near its upper end, and a series of ratchet-teeth, *d*², in its edge, near its lower end. It is also provided with a handle, *e*², by which it may be moved. A spring is attached to an eye at the back of the bar B², and to the stud *b*², for the purpose of drawing the bar downward.

A spring-pawl, *f*², is pivoted at *g*², and is provided with a finger, *h*², which diverges from the bar B². A pin, *i*², projects from the end piece M, and engages the pawl *f*² when the head H is at the lower portion of the main frame, and engages the arm *c*² when the said head is at the upper part of the main frame.

A treadle, C², is pivoted in the hangers *j*², that are attached to the cross-bar B. To this treadle the rods *o* are jointed; and bent levers D², which are pivoted in ears E² at the sides of the main frame, are also connected with it by means of links or short connecting-rods, *k*². A spring, F², is attached to the cross-bar B, and to the treadle C², for drawing the latter upward as it is released by the foot.

Plates *l*² are attached to the side pieces A, for tripping the dogs *s*.

The operation of my improved machine is as follows: An uncrimped upper is placed on the beveled pieces F when all of the parts are in the position shown in Figs. 1, 2, and 4. Motion is imparted to the pulleys *t*¹ *t*² to drive them in opposite directions; the foot is placed on the treadle C² with sufficient force to raise the levers K, so as to retract the screw *l* and throw the levers D² under the ends of the frame G; the levers *i*¹ are moved so as to lock the toggle in the follower O and the bar B² is raised until one of the notches, *d*², is engaged by the pawl *f*². By this means the clutch W is brought into engagement with the rotating pulley *t*¹, which carries the clutch and, consequently, the shaft V, and rotates the internally-threaded sleeve, so as to drive the head H downward, the frame G being prevented from descending by the levers D². The corrugated pieces N clamp the leather down upon the beveled pieces F, and the dogs *s* engage the studs *p* simultaneously. The treadle C² is now released, when it is raised by the spring F² throwing the upper ends of the levers D² outward, so that the frame G may descend with the head H, and at the same time the weighted ends of the levers K descend and turn the nuts L, carrying the screws *l* forward, so as to move the levers *i* and throw the plates E and the beveled pieces F upward, clamping the leather with more or less force between the beveled pieces F and the beveled and corrugated pieces N. At the same time the rollers *q*¹ of the levers *o*¹ become disengaged from the face of the arms *r*¹, and roll under the said arm and permit the weights *p* to descend gradually, turning the screws *a*¹, and

forcing the followers O toward the tree D, and causing the corrugated plates *v* to press on the leather on the tree with a gradually-increasing force. The head H and frame G descend together, the leather, meanwhile, being drawn smoothly over the tree by the beveled pieces F N, and further pressed and smoothed by the corrugated plates *v*. When the operation of crimping is completed the arms *t* of the dogs *s* touch the trips *l*², and move the dogs so that the frame G drops down, and permits the beveled pieces F to fall away from the corrugated pieces N. Immediately after this is done the arms *h*¹ of the three-arm levers *c*¹ strike the cams *J*¹ and unlock the toggle in the followers O and retract the said followers. The pin *i*² now trips the pawl *h*², allowing the bar B² to drop and throw the clutch W into the wheel *t*², which, being rotated in the direction opposite to that of the wheel *t*¹, reverses the motion of the shaft V and sleeve R, and causes the head H to rise until the pin *i*² strikes the arm *c*² and stops the machine by throwing the clutch W into a central position between the two pulleys. The crimped leather is now removed, and the operation may be repeated.

Having thus fully described my invention, I claim as new and desire to secure by Letters Patent—

1. The combination, in a crimping-machine, of a head, made as described, and two followers carrying corrugated plates, a screw and a nut for moving each follower, and a toggle for locking and releasing them, substantially as shown and described.

2. The combination of the head H, having the end pieces M and sleeves P, the followers O, link *f*, three-arm levers *c*¹, nuts *w*, screws *a*¹, and weighted lever *o*¹, substantially as shown and described.

3. The adjustable arms *s*¹, in combination with the sleeve P and lever *o*¹ for limiting the motion of the latter, substantially as specified.

4. The arms *r*¹, in combination with the weighted levers *o*, provided with rollers *q*, substantially as shown and described.

5. The combination of the lever *i*¹ with the lever *c*¹ for releasing the follower O, substantially as shown and described.

6. The movable frame G, having the studs *p*, in combination with the head H, carrying the dogs *s*, for supporting the leather-clamping mechanism, as shown and described.

7. The levers K, having the eyebolts *n* and toothed sectors L, the nuts I, having the toothed sectors J, the screws *l*, and levers *i*, in combination, for operating the leather-clamping jaws, substantially as shown and described.

8. The plates E, placed in the grooves in the vertical posts C on opposite sides of the tree D, and provided with adjusting-screws *f*, in combination with the curved beveled pieces F and the mechanism for operating the plates, substantially as shown.

9. The combination, in a leather-crimping machine, of the beveled curved pieces F and the beveled corrugated and curved pieces N for drawing the leather over the tree, substantially as herein shown and described.

10. The cams *J*¹, affixed to the side pieces A, for tripping the lever *h*¹, substantially as and for the purpose herein shown and described.

11. The combination of the bar B², having the slot *a*², arm *c*², and ratchet-teeth *d*², the pawl *f*², the pin *i*², and shifting lever *v*, substantially as shown and described.

JASON SMITH.

Witnesses:

C. SEDGWICK,
ALEX. F. ROBERTS.