

B. N. BAILEY.
BURGLAR-ALARM.

No. 193,210.

Patented July 17, 1877.

Fig. 1.

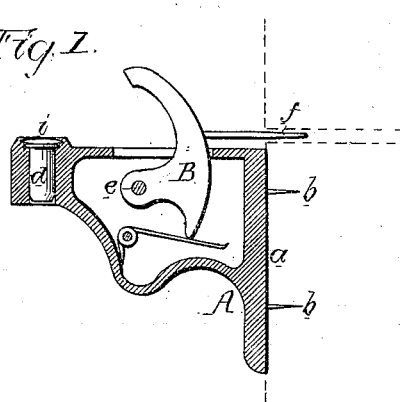

Fig. 2.

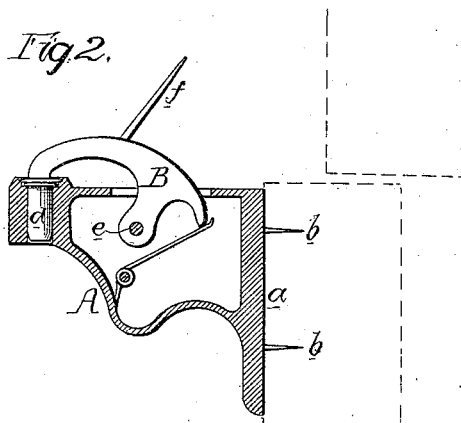
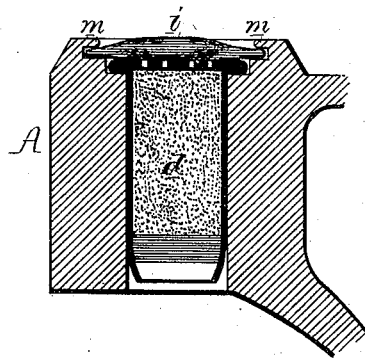

Fig. 3.



Witnesses
Henry Howson, Jr.
Harry Smith

Inventor
B. N. Bailey
by his Attorneys
Howson and Co.

UNITED STATES PATENT OFFICE.

BENJAMIN N. BAILEY, OF PHILADELPHIA, PENNSYLVANIA, ASSIGNOR OF ONE-HALF HIS RIGHT TO EUGENE NAEGELE, OF SAME PLACE.

IMPROVEMENT IN BURGLAR-ALARMS.

Specification forming part of Letters Patent No. 193,210, dated July 17, 1877; application filed May 21, 1877.

To all whom it may concern:

Be it known that I, BENJAMIN N. BAILEY, of Philadelphia, Pennsylvania, have invented a new and useful Improvement in Burglar-Alarms, of which the following is a specification:

The object of my invention is to construct a cheap and simple burglar-alarm, an object which I attain in the following manner, reference being had to the accompanying drawings, in which—

Figures 1 and 2 are vertical sectional views of my improved burglar-alarm, showing the moving parts in different positions; and Fig. 3, an enlarged view of a portion of the device.

A is a casing, one edge, *a*, of which is adapted to the face of a door or window, or to the frame of the same adjacent to the edge, the casing being secured in position after adjustment by means of the pins *b*, or other suitable devices, such as screws, hooks, or staples.

In the outer end of the casing A is formed an opening, to which is adapted the body of a blank cartridge, *d*, the upper end of the opening being enlarged, so as to form a shoulder, on which the head of the cartridge rests.

A spring-hammer, B, is pivoted to the casing at *e*, and this hammer is provided with a finger, *f*, projecting from its rear side, as shown.

In the head of the cartridge *d* are formed a number of perforations, as shown in Fig. 3, and when the apparatus is in use a cap, *i*, of such a character that it can be exploded by a comparatively slight blow, is laid upon the head of the cartridge, as shown.

I prefer to use for this purpose a paper disk containing the usual fulminating compound,

the disk being retained in position by a flange, *m*, formed on the casing, and either wholly or partially surrounding the cap.

The operation of the device is as follows: The hammer B is raised until the finger *f* rests against the edge of the door or window, and the latter is then closed, the finger *f* being contained in the opening between the door or window and its frame. As soon as the door or window is moved slightly in the act of opening, however, the finger *f* will be released and the hammer B will fall, as shown in Fig. 2, striking and exploding the cap *i*, which, owing to the perforations in the head of the cartridge, ignites the explosive contents of the latter and causes its discharge.

By the use of the perforated cartridge and supplementary cap I am enabled to dispense with the heavy springs heretofore used in cartridge burglar-alarms, thus considerably cheapening and simplifying the construction of the device.

I claim as my invention—

The combination of a door or window and its frame with the casing A, carrying a cartridge, *d*, and spring-hammer B, with finger *f*, and having a face, *a*, adapted to said window, door, or frame, and provided with pins *b*, or equivalent device, as described, for attachment thereto, as set forth.

In testimony whereof I have signed my name to this specification in the presence of two subscribing witnesses.

B. N. BAILEY.

Witnesses:

HERMANN MOESSNER,
HARRY SMITH.