

C. A. HOTCHKISS.
CURRY-COMB.

No. 193,251.

Patented July 17, 1877.

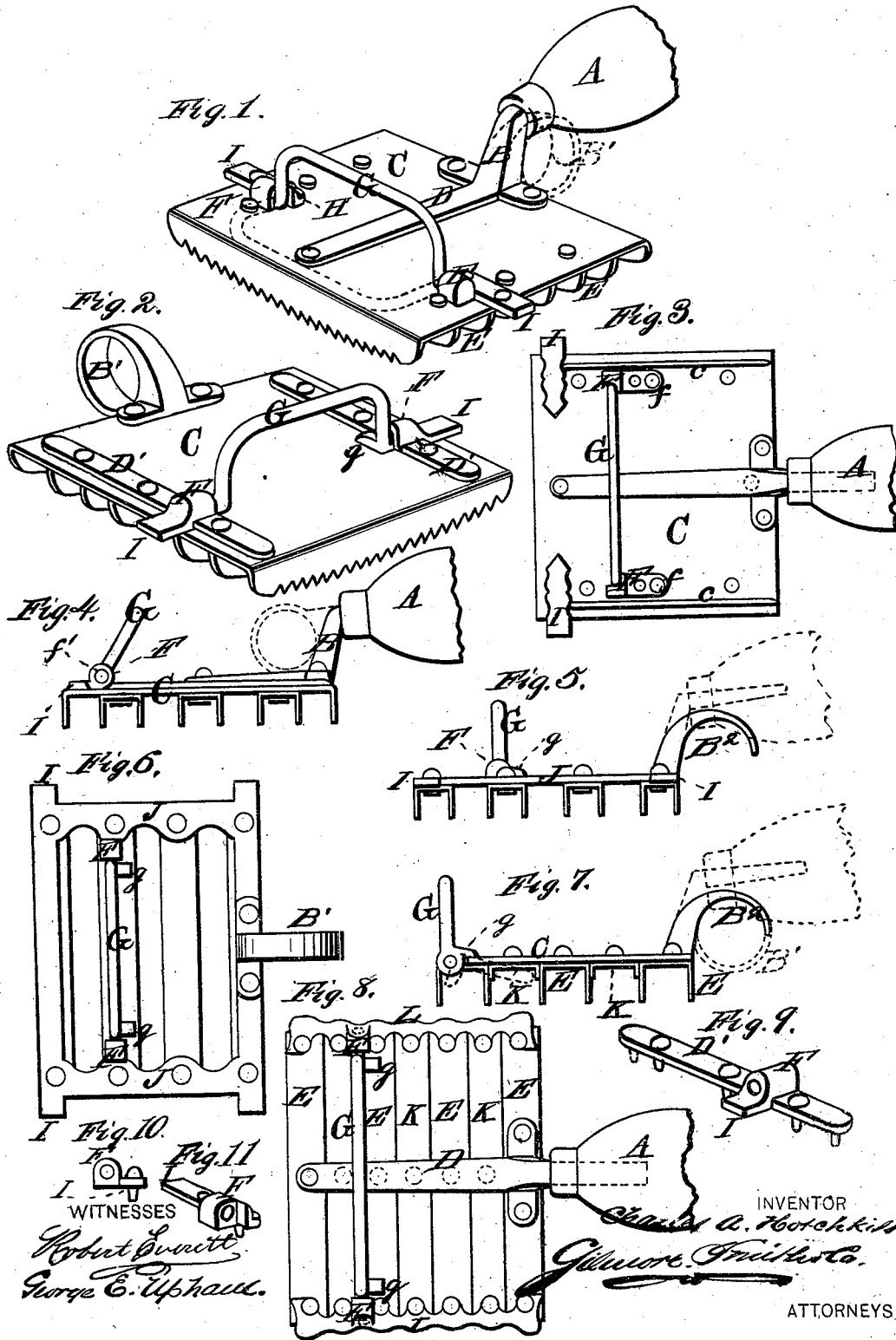

WITNESSES
Robert Swatt
George E. Uphall

INVENTOR
C. A. Hotchkiss
Gilmore & Frutkin

ATTORNEYS.

UNITED STATES PATENT OFFICE.

CHARLES A. HOTCHKISS, OF BRIDGEPORT, CONNECTICUT.

IMPROVEMENT IN CURRY-COMBS.

Specification forming part of Letters Patent No. **193,251**, dated July 17, 1877; application filed October 10, 1876.

To all whom it may concern:

Be it known that I, CHARLES A. HOTCHKISS, of Bridgeport, in the county of Fairfield and State of Connecticut, have invented a new and valuable Improvement in Curry-Combs; and I do hereby declare that the following is a full, clear, and exact description of the construction and operation of the same, reference being had to the annexed drawings, making a part of this specification, and to the letters and figures of reference marked thereon.

Figure 1 of the drawings is a representation of a perspective view of my curry-comb, and Fig. 2 is a perspective view of a modification. Fig. 3 is a plan view of another modification of my curry-comb, and Figs. 4 and 5 are side elevations of modifications thereof. Fig. 6 is also a plan view of a modification, and Fig. 7 is a side elevation of a modification. Fig. 8 is another plan view of a modification of my curry-comb, and Figs. 9, 10, and 11 are detail views of my curry-comb.

This invention relates to curry-combs; and it consists in providing said combs with a finger-grasping device, pivoted in pivot-blocks over the back of the comb, and adapted to be folded down for the purpose of packing. It also consists in the combination, with the side handle of a curry-comb, having a thumb-rest, of a pivoted finger-grasping device, and stop-lugs which prevent said finger-grasping device from being turned down toward the said side handle.

In the annexed drawings, Figure 1 shows a closed-back comb, provided with an ordinary side handle, A, which receives the tang of a raised rearwardly-inclined shank, B, that is riveted to a rectangular back plate or shell, C. Said shell or back plate is stiffened by a strengthening-bar, D, which is made in one piece with shank B, and is also riveted to said back plate. E E designate the teeth-bars, which are constructed in the usual way, and riveted to the under side of said back plate or shell. On the top of said back plate or shell, at both sides thereof, and between the middle and the front edge of said shell, are secured two lugs or pivot-blocks, F F, which are recessed on their under sides, next said shell, so as to receive the straight ends or journals of an arched grasping-bar, G, which may be folded forward and downward, as shown in dotted lines, for

packing, or may be turned up into a vertical position for use. Said grasping-bar is prevented from turning over toward the handle by means of stop-lugs H H, which are rigidly connected to said pivot-blocks, and extend behind said grasping-bar. This enables the operator's fingers to hold said grasping-bar firmly when his thumb is behind shank B. I I designate combined rigid knockers and pivot-blocks F F. They facilitate the cleansing of the comb, and prevent the ends thereof from being injured when struck, for the above purpose, upon any hard substance. Each knocker is preferably constructed in one piece with a pivot-block and stop-lug. The riveting of said knockers and pivot-blocks to the back plate also attaches said pivoted finger-grasping bar G thereto. If preferred, side handle A and shank B may be dispensed with, and a thumb-ring, B¹, or curved thumb-rest, (shown in dotted lines,) may be substituted therefor. The above-described devices may be employed in an open-back comb instead of a closed-back comb.

Fig. 2 represents a closed-back comb similar to that shown in Fig. 1, but differing therefrom in the following respects: Instead of a shank and middle strengthening-bar, it has two strengthening-bars, D' D', which are riveted to the top of back plate or shell C at the ends of the same, and extend nearly from the front to the rear thereof. Pivot-blocks F F and knockers I I occupy the same positions as in Fig. 1, and their construction is substantially the same; but each one of said pivot-blocks is made in one piece with one of said strengthening-plates and with one of said knockers. A thumb-ring, B¹, is shown in this figure; but any form of thumb-rest hereinbefore described may be substituted therefor. The attachment of the grasping-bar G is the same as in the first figure. Stop-blocks g g are in one piece with said grasping-bar.

Fig. 3 is constructed precisely like Fig. 1, except that the knockers I I are made separate from the pivot-blocks F F. The said pivot-blocks are provided with attaching-plates f f. Stiffening-ribs c c are raised upon the back of shell C, near the ends thereof, and the said pivot-blocks are perforated, instead of being recessed on the under side.

Fig. 4 shows the pivot blocks or lugs F F,

each made in one piece with one of the knockers I I, and arranged at or near the front of the comb back or shell C. Said pivot-blocks are in this case made cylindrical, and provided with central perforations *f' f'*, in which are pivoted the ends of raised finger-grasping bar G. There are no stop-lugs either on the said grasping-bar or the pivot-blocks C, so that the said pivoted grasping-bar may be folded down toward the said side handle, upon the said back plate or shell, for convenience in packing. As shown in dotted lines, a thumb-ring may be secured to the front of shank B, or made in one piece therewith. In most other respects this modification does not differ from that shown in Fig. 1.

Fig. 5 shows an open-backed comb, having its pivot-blocks F made in one piece with its end plates J, and arranged between the middle and the front edge of the comb. The pivoted grasping-bar G is provided, as in Fig. 2, with stop-lugs *g g*, made in one piece with it. The curved or semicircular thumb-rest B² is cast with or otherwise rigidly attached to the back frame of the comb. A shank and side handle (shown in dotted lines) may be substituted therefor. The knockers I I are made in one piece with the end plates J J.

Fig. 6 shows another modification, similar to that last described, but employing a thumb-ring, B¹. There is no other difference between these two forms of combs.

Fig. 7 shows a modification having its grasping device G pivoted to the front of its back plate or back frame C, and adapted to fold under the said comb for convenience in packing, as indicated by dotted lines. Said grasping-bar G is provided with stop-lugs *g g*, as in the case last described. Instead of thumb-rest B² I may substitute a thumb-ring, B¹, or shank and side handle, as shown in dotted lines. This comb is provided with filling-plates K K, which are interposed between the teeth-bars E E, and change the said comb from an open-back into a closed-back one. Stop-lugs *g g* may be attached to the back frame of the comb, as hereinbefore described, instead of to the pivoted grasping-bar.

Fig. 8 shows a comb which has scalloped end plates L L, which serve as knockers. Said scalloped end plates are each made in one piece with one of the two pivot-blocks F F. Pivoted grasping-bar G is provided with stop-lugs *g g*, as in Fig. 6. D is a strengthening or bracing bar, similar to that shown in Fig. 1, and is riveted to the backs of the

teeth-bars E E, filling-plates K K, or both; or to the front and rear teeth-bars only. Instead of side handle A, a curved thumb-rest or thumb ring (shown in dotted lines) may be used. There is no back frame other than said end plates L L and said strengthening-bar.

Any form of back may be used with any of the herein-described arrangements of finger-grasping devices, and any of the equivalents for a raised side handle, such as a thumb-ring or thumb-rest, may be substituted interchangeably therefor.

Fig. 9 shows, in detail, an end plate, D', pivot-block F, and knocker I, all constructed in one piece, as in Fig. 2, but having a perforation extending through said pivot-block to receive one of the horizontal ends or journals of the pivoted grasping-bar. Figures 10 and 11 show, in detail, a pivot-block, F, and knocker I, made in one piece, as in Fig. 1, but having a perforation extending through said pivot-block from the inside to the outside thereof, for the reception of the straight ends or journals of the grasping-bar.

What I desire to claim as new, and secure by Letters Patent, is—

1. In combination with a curry-comb having a thumb-rest, a finger-grasping device pivoted to the comb in raised bearings at the back of the comb, substantially as set forth.
2. In combination with a curry-comb having a thumb-rest and knockers, a finger-grasping device pivoted in raised bearings at the back of the comb, substantially as set forth.
3. In combination with a curry-comb having a thumb-rest, a finger-grasping device pivoted in raised bearings at the back of the comb, said bearings being provided with extensions to form knockers, substantially as set forth.
4. In combination with a curry-comb having a thumb-rest, a folding finger-grasping device having stop-lugs and journals constructed in one piece therewith, and arranged substantially as set forth.
5. In combination with a curry-comb having a thumb-rest, a finger-grasping device pivoted in raised bearings at the back of the comb, and stop-lugs, substantially as set forth.

In testimony that I claim the above I have hereunto subscribed my name in the presence of two witnesses.

CHARLES A. HOTCHKISS.

Witnesses:

J. F. ACKER, Jr.,
C. H. McEWEEN.