

J. KEITH.
 CLAMPS FOR PAPER-CUTTING MACHINES.

No. 193,256.

Patented July 17, 1877.

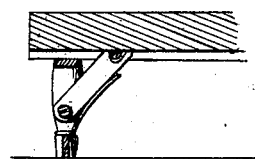
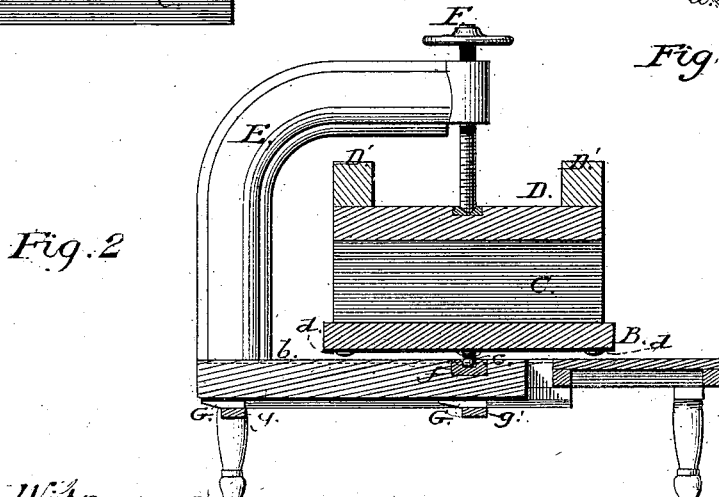
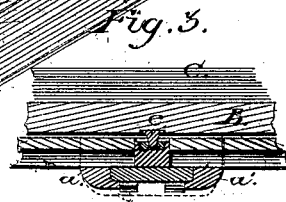
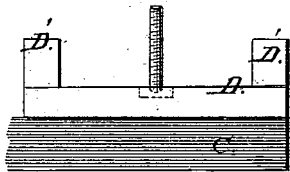
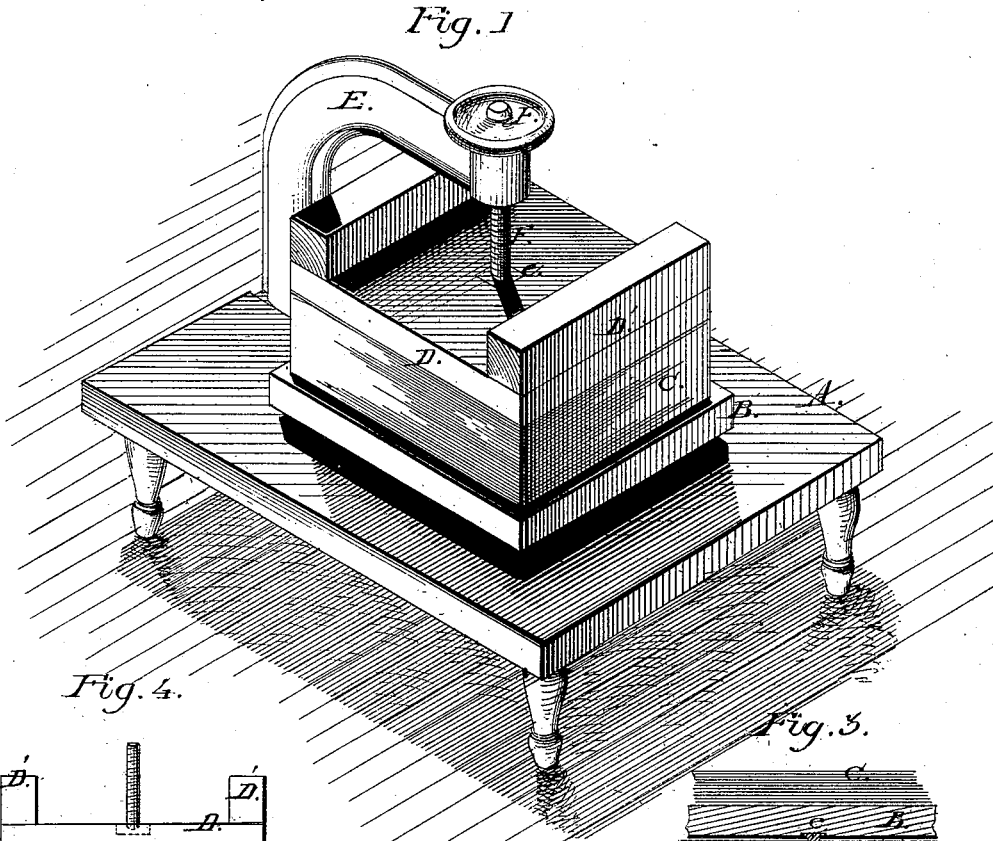

Witnesses:
 Chester C. Conant
 Fred L. Green

Inventor:
 John Keith
 James H. Brown
 atty.

UNITED STATES PATENT OFFICE.

JOHN KEITH, OF GREENFIELD, MASSACHUSETTS.

IMPROVEMENT IN CLAMPS FOR PAPER-CUTTING MACHINES.

Specification forming part of Letters Patent No. **193,256**, dated July 17, 1877; application filed June 23, 1877.

To all whom it may concern:

Be it known that I, JOHN KEITH, of Greenfield, in the county of Franklin, and Commonwealth of Massachusetts, have invented a new and useful Improvement in a Machine for Clamping Paper to be Cut or Trimmed, to be used especially in manufactories of paper and in book-binders; and I hereby declare the following to be a full and exact description thereof, reference being had to the accompanying drawings, making a part of this specification, in which—

Figure 1 is a perspective view of my machine as in use. Fig. 2 is a vertical section, showing the upper arm of clamp in elevation. Fig. 3 is a transverse section, showing the form of the ways, the incline planes, bed-plates, &c. Fig. 4 is a detail view, showing, in elevation, the form which rests upon a pack of paper to be cut. Fig. 5 shows a modification of the device for lifting the bed-plate free of the table.

Similar letters of reference denote like parts in all the drawings or figures.

In the manufacture of paper to prepare it for market and for use, it is necessary to cut or trim the edges, especially of flat-cap, folio, and other fine paper, exactly true and square. This is usually done by placing a bundle of otherwise finished paper, of one or more reams, having its rough edges placed as nearly as possible square, on a bed, and there secured by a clamp holding it by means of a form of the exact size of the paper when cut, which acts as a guide for the cutting, and pushed up on a table to the knife, which, by proper machinery, is made to descend and to trim off one edge squarely. The bundle of paper then being withdrawn, is unclamped and turned upon the bed. The trimmed or square edge being placed back against straight-edged guides, is again clamped, and the bed holding it again pushed forward, three times successively, till each of the other edges is trimmed. The bed holding the paper is independent of the table, and much time and hard labor are involved in pushing, withdrawing, and rearranging the bundle. It is also very difficult to readjust the paper once trimmed, so as to secure perfectly-trimmed edges on the opposite side. I propose by my invention to save

one-half the time, and almost entirely to avoid the labor of this process.

A is the table on which the bed-piece holding the paper to be cut rests. It is supported in any usual way, and has from its rear side a slot cut through about three-quarters of its width, in which the lower arm of the clamp slides.

On the under side of the table, one on each side of the slot, and parallel with it, are fastened two iron ways, *a a'*, rabbeted on their upper sides to receive the lower arm *b* of the clamp E, which is rabbeted on each side to make a sliding joint sufficiently open to allow the clamp to be raised or lowered, as hereinafter described. Across the space between these ways are two bars, *g g'*, one near the rear end and one about one-fourth of the distance from the front end, the object of which is to receive the inclines G on the under side of the lower arm of the clamp, as hereinafter described. These bars also serve to strengthen the slotted table.

E is the clamp for holding the paper to be trimmed firmly on the bed-plate B, having in the end of its upper arm a screw, F, for that purpose. The lower arm of this clamp runs in and through the slot in the table, and is rabbeted to fit in the ways *a a'* on the under side of the table. On the under side of this arm of the clamp are fastened two inclines, G G, one at each end, the sharp end of the inclines pointing toward the rear end of the table. These inclines are so placed as to run on the bars *g g'*, across the ways, so that when the clamp is pushed forward to its full extent, the inclines are inoperative. The clamp rests a little lower than the line of the table, allowing the bed holding the paper to rest firmly on the table, supported by the studs *d* in the bottom, to receive the force of the cut of the knife, but as soon as the knife has descended, the clamp holding the trimmed paper is withdrawn, and the inclines, rising on the bars across the ways, raise the clamp, both ends simultaneously, up to the line of the table, and allow the bed-plate holding the paper to be readily turned on the stud or pivot on the under side, for another cut. A stop suitably placed prevents the clamp from being entirely withdrawn. These ways and inclines can be

made in the edge of the table on each side of the slot.

The same purpose—that of raising and lowering the clamp, which is the important element in my invention—may be accomplished by the use of cams, or of short levers secured to the under side of the table, and acting on the lower arm of the clamp.

B is the bed-plate, upon which the bundle of paper is laid, and which has on its under side a number of studs or feet, *d*, on which it can rest firmly on the table while the paper is being cut upon it. On the center of the under side is a stud or pivot, *c*, which rests in a socket, *f*, on the end of the under arm of the clamp by which it is supported, and on which the bundle of paper is readily turned, the pivot being just long enough to clear the bed-plate from the table, when, the clamp being withdrawn, the inclines raise it to the level of the table, or to allow the bed-plate to rest on the table, when the clamp is pushed forward past the action of the inclines, or other device for raising or lowering the clamp.

D is the form, which is placed on the bundle of paper to secure the sheets in a fixed position, and is the exact size of the paper when trimmed. It has on the center of its upper side a socket, *e*, in which fits the end of the screw F, which runs in the clamp. It has two upstanding sides, *D'*, which, usually protected by metal slips, serve as guides to bring the package square to the knife.

The manner of using my improvement is simply this: A package of paper is placed squarely on the bed-piece; the form is placed on top and clamped down by the screws; the clamp, thus having the paper secured, is thrust forward; the knife descends through the package, which is withdrawn, rising a little by the inclines free of the table is turned a quarter round, pushed forward, is again trimmed, and so on till the four sides are finished, when the clamp is loosened, and the package removed.

I claim—

1. The combination of the arm E, provided with inclines G G, or their equivalent, with the slotted table A, having guideways *a a'*, and cross-bars *g g'*, as set forth.

2. The slotted table A, provided with guideways *a a'* and cross-bars *g g'*, substantially as described, for the purpose set forth.

3. The U-shaped clamp-arm E, provided with screw F and inclines G G, and adapted to operate in connection with a slotted table having guideways, as specified.

4. The clamping mechanism herein described, consisting of the slotted table A, pivoted bed-plate B, form D D', and arm E having screw F, and inclines G G, for the purpose specified.

Witness my hand this 7th day of June, 1877.

JOHN KEITH.

Witnesses:

JAMES S. GRINNELL,
C. M. BURNETT.